

A Driver-Specific Maneuver Prediction Model Based on Fuzzy Logic



Colin Bauer

Dissertation zur Erlangung der Doktorwürde
der Naturwissenschaften

Eingereicht am Fachbereich Mathematik und Informatik
der Freien Universität Berlin, Dezember 2011

Erstgutachter: Prof. Dr. Raúl Rojas

Zweitgutachter: Prof. Dr. Rudolf Kruse

Tag der mündlichen Prüfung: 09.02.2012

Abstract

This thesis describes a method for the driver-adaptive prediction of driving maneuvers. This method builds a model of the driving behavior from data based on the observation of sample driving maneuvers. The method is grounded on the theory of fuzzy logic, which provides a framework for reasoning about a domain that approximates human reasoning. After a learning period, the driver model is capable of predicting subsequent driving maneuvers. That information can be used to adapt advanced driver assistance systems, as exemplified by an autonomous braking system, to the driver's individual behavior. This thesis contains three major contributions. The first is the driver-adaptive construction of fuzzy variables. A method was developed that converts histograms into fuzzy variables by approximating them through Gaussian Mixture Models and converting the resulting Gaussian distributions into trapezoidal fuzzy sets. These fuzzy variables partition quantities of interest, such as vehicle velocity, into fuzzy sets that have well defined and driver-specific semantic meanings. The second contribution is the generation of a driver-adaptive fuzzy state machine modeling the sequential pattern of driving maneuvers based on sample data. A quality measure assessing the performance of states and state sequences was developed that optimizes the state machine, resulting in an accurate and analyzable representation of individual driving behavior. The third contribution is the development of a driver-adaptive and situation-specific autonomous braking algorithm. The algorithm triggers an autonomous brake in a specific relevant critical situation, taking into account the prediction of individual driving behavior in the decision process. It could be shown through a simulator study that the algorithm is capable of significantly reducing the severity of, or even avoiding, the collisions that were encountered in that study, without also causing any undesired activation of the autonomous brake, thus providing significant assistance to the driver.

Acknowledgements

First and foremost I would like to thank my family and friends for their support during the course of this thesis. Special thanks go to my wife, Anke, for enduring all those recurring long nights and weekends that I spent working on this project. Without her support and the occasional hot coffee that mysteriously appeared next to my computer the task would have been much more difficult. I am also grateful to all my friends for not giving up on me during those periods of partial disappearance.

My thanks go to all my colleagues at Carmeq and Volkswagen, especially everyone at FA1/FA2 and K-EFFS/I, for providing an enjoyable and intellectually inspiring atmosphere. Special mentions go to Till Freiburg and Pascal Held for their committed support in the elaboration and execution of the field studies that provided the necessary data for the evaluation of the concepts developed in this work. I want to thank my superiors at Carmeq and VW, Jürgen Müller and Dr. Mark Gonter, for backing me up in my decision to pursue this degree and laying the proper foundations that allowed me to reach my goal.

The members of the AutoNOMOS labs at FU Berlin also deserve special mention. Especially in the beginning of my journey, several fruitful discussions helped me find answers to the problems I was facing at the time. Many of the questions that I received when presenting preliminary results were very appropriate and made me challenge my own ideas.

Finally, I want to thank my reviewers, Prof. Rudolf Kruse and Prof. Raúl Rojas. Prof. Kruse receives my sincere gratitude for kindly accepting to review my thesis, when there was absolutely no obligation to do so. I am especially grateful to Prof. Raúl Rojas for giving me the opportunity to pursue my goals under his guidance, always giving excellent advise when I was in need of it. This project would never have been attempted in the first place without his support.

Contents

Preface	1
1 Introduction	3
1.1 Motivation	3
1.2 The history of driver modeling	8
1.2.1 Driver models focusing on the vehicle	9
1.2.2 Driver models focusing on vehicle/driver combination	11
1.2.3 Driver models focusing on environment/traffic	12
1.3 Driver models focusing on the driver	14
1.4 Advanced driver assistance systems	18
1.4.1 Driver information systems	19
1.4.2 Comfort systems	20
1.4.3 Semi-autonomous systems	21
1.4.4 Autonomous systems	22
1.5 Driver modeling and active safety systems	24
2 Driving maneuver prediction	27
2.1 Definitions of driving maneuvers	27
2.2 Overview of maneuver prediction models	29
2.3 Cognitive driver modeling	31
2.4 Behaviorist driver modeling	37
2.4.1 Driver models based on neural networks	38
2.4.2 Driver models based on Bayesian networks	39
2.4.3 Driver models based on hidden Markov models	42
2.4.4 Driver models based on fuzzy logic	45

CONTENTS

3	A fuzzy logic based driver model	47
3.1	Introduction	47
3.2	Fuzzy Logic	50
3.3	Driver-dependent fuzzy variables	53
3.3.1	Histogram generation from sample data	56
3.3.2	Histogram approximation through a Gaussian-Mixture-Model	59
3.3.3	Conversion of a Gaussian Mixture Model into a Fuzzy Variable	65
3.4	Driver-dependent fuzzy rulebase	73
3.4.1	Variable decomposition	75
3.4.2	Intermediate rules generation	76
3.4.3	Rule tournament	78
3.4.4	Rule compression	79
3.5	Driver-dependent fuzzy state machine	80
3.5.1	Rule effectiveness and belief calculation	80
3.5.2	Fuzzy state machine calculation	85
4	Evaluation of the driver model	89
4.1	Driver modeling field study	89
4.1.1	The vehicular test platform	89
4.1.2	The driving route	92
4.1.3	The test group	95
4.2	Stopping maneuver prediction in urban environments	95
4.2.1	Fuzzy Variables for stopping maneuver prediction	96
4.2.2	Sample maneuvers for stopping maneuver prediction	102
4.2.3	Evaluation of the stopping maneuver prediction	104
4.2.4	Analysis of the stopping maneuver prediction model	107
4.3	Turning maneuver prediction in urban environments	112
4.3.1	Fuzzy Variables for turning maneuver prediction	112
4.3.2	Sample maneuvers for turning maneuver prediction	116
4.3.3	Evaluation of the turning maneuver prediction	117
4.3.4	Analysis of the turning maneuver prediction model	119

5 A driver-adaptive longitudinal emergency braking algorithm	121
5.1 A detailed overview of Collision Mitigation	121
5.2 Description of the emergency braking algorithm	125
5.2.1 Definition of the critical situation	125
5.2.2 Driver-dependent measure of situation criticality	127
5.2.3 Prediction of driving intent in critical scenarios	129
5.2.4 Description of the emergency braking algorithm	130
5.3 Evaluation of the emergency braking algorithm	131
5.3.1 The simulator study	132
5.3.2 Implementation of the emergency braking algorithm	136
5.3.3 Evaluation of the emergency braking algorithm	139
6 Conclusion	145
List of Figures	151
List of Tables	155
References	156
A Zusammenfassung	163
B Fuzzy variables of the field study	165
C Situation criticality variables of the field study	171
D Situation criticality variables of the simulator study	173

CONTENTS

Preface

This thesis describes a method that predicts driving behavior based on sample driving maneuvers extracted under regular driving conditions. Since driving behavior can differ substantially between drivers, the method generates a model that is specific to the driver and his observed behavior. Knowledge about the execution of relevant maneuvers can be used to adapt advanced driver assistance systems (ADAS) to the driver's behavior, leading to potential improvements in the system's performance and user acceptance.

The driver model developed in this thesis is based on the theory of fuzzy logic, which provides a methodology for reasoning about the application area that approximates human reasoning. The theory introduces the mathematical representation of a fuzzy set, which enables the partition of a quantity involved in the reasoning process into individual concepts, taking into consideration the uncertainty about the boundaries between these concepts. Based on the partitions of quantities into fuzzy sets, the fuzzy variables, it is possible to model reasoning using a rule-based approach consisting of a set of rules describing a process, in this case driving maneuvers.

One key aspect of the model developed in this thesis is the partition of those quantities relevant for the prediction of driving maneuvers into fuzzy variables. Since each human has a somewhat different notion of these concepts, the fuzzy variables need to reflect these individual differences. In this thesis, a method is presented that accomplishes this partition by observing the respective variables for an appropriate amount of time during regular driving, using the gathered information to define the fuzzy sets.

The second central part of the model is the generation of a rulebase that models the driver's behavior during the execution of a maneuver. As with the definition of a fuzzy variable, the way how driving maneuvers are performed varies across drivers, requiring a method that generates driver-dependent rules representing the driving behavior. This is achieved in this thesis through data from sample driving maneuvers extracted during regular driving. A rulebase describing the driver's behavior is generated from these training samples using the fuzzy variables described above. At periodical points in time, rules describing the individual stages of the maneuver are identified. The resulting sequence of rules is a driver-dependent representation of driving behavior that can be used for the prediction of the respective maneuver type.

The effectiveness of the driver modeling method is evaluated with data from a field study. In that study, several participants completed a route including urban and rural roads as well as highways. The relevant data was recorded and models generated by means of the method developed in this thesis for two exemplary maneuvers, stopping behind a vehicle and turning left at an intersection in inner-city areas. To that end, relevant maneuvers were extracted and the driver-dependent fuzzy variables and rule-base generated from each participant's data. Finally, the performance of the resulting maneuver prediction models was evaluated.

The prediction of the driver's intention can be used to adapt advanced driver assistance systems. Many different ADAS can benefit from that information. One type of ADAS where a substantial benefit for the individual driver can be achieved is that of Collision Avoidance (CA) / Collision Mitigation (CM). The goal of systems of this type, examples of which are provided in this thesis, is to reduce the effects of a collision or even avoid it by either braking, which is already available in commercial vehicles, or steering away from the obstacle, which is in the stage of ongoing research. The critical aspect of such a system is when to initiate the autonomous braking / steering maneuver. Clearly, the earlier a system is activated, the higher its effectiveness. However, this potentially also increases the chances of activating the actuator unnecessarily, causing a potentially dangerous situation. This is one of the main reasons why most currently available systems only perform full braking when a collision is unavoidable, only reducing the collision's severity as a result.

To show the benefit of driver modeling for the development of CA / CM systems, a driver-adaptive autonomous braking algorithm is developed in this thesis. This system includes the prediction of the driver's stopping behavior in its decision, allowing for an driver-adaptive activation of the vehicle's brake. It is shown through an experiment in a driving simulator that the algorithm is able to successfully avoid or strongly reduce the impact of a collision in a specific scenario of high practical relevance, without causing incorrect or premature activations of the brake, which could have negative effects on vehicle safety and user acceptance.

1

Introduction

1.1 Motivation

The development of advanced driver assistance systems has increased substantially in recent years. Nowadays, many vehicle manufacturers offer driver assistance systems in their vehicles. These systems are no longer restricted to premium class vehicles, but have reached most other market segments as well. This development is expected to continue, leading to a higher number of assistance systems in an even wider range of vehicles. The more these systems are introduced into the market, the higher their impact can be expected to be on the driver, his driving behavior and traffic in general. The increase in comfort and safety of the driving task are two of the main motivations for the development of such systems. The better a vehicle manufacturer is capable of assisting in these two areas, the larger is the incentive for the consumer to buy those systems and as a result the commercial success and reputation of the manufacturer.

As a consequence, many companies and universities are engaged in the optimization of existing and development of novel assistance systems. Especially in the field of active and passive safety systems, the area concerned with the avoidance of collisions or the mitigation of the collision's consequences, much effort has been invested by companies, institutions and governments in the optimization of these systems. Technologies from passive (e.g. airbags) and active (ESP, ABS, see section 1.4.4) safety have helped reduce the severity of accidents substantially. In Germany for instance, the number of people killed in car accidents has dropped by 50% from around 20 per one billion kilometers in 1985 to about 10 per one billion in 2000 as reported by the German

1. INTRODUCTION

Statistics Agency¹ [1], even though the amount of traffic has increased significantly within that time period. This development has been so promising that governments have supported research efforts to reduce the number even further. Sweden, for instance, has been following an initiative called 'Vision Zero'² for over a decade, which has the ambitious goal of preventing all fatalities on Swedish highways. In order to achieve this, improvements have to be made in a variety of areas, not only in vehicle technology, but road infrastructure, education and surveillance as well. It has so far been considerably successful, as can be seen in the development of the number of fatalities on Swedish roads recorded by the Swedish Road Administration, as depicted in Fig. 1.1 taken from the initiative's website³. The European Union co-funded a large project

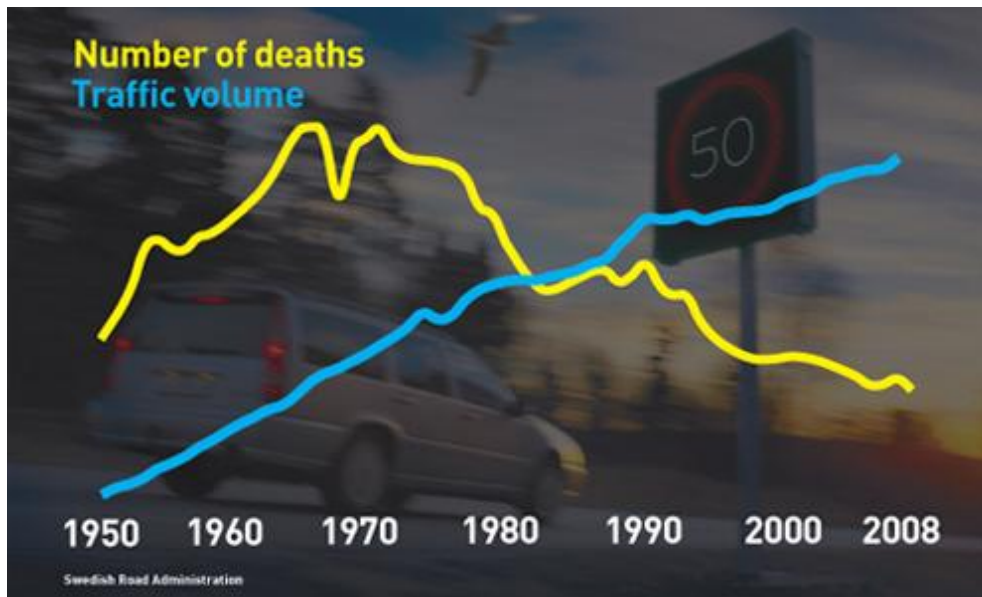

Figure 1.1: Evolution of fatal accidents on Swedish roads,⁴

Prevent⁵ connecting the European automotive industry and research institutes that had the ambitious goal of reducing the number of accidents by 50% by 2010 through the improvement of preventive safety applications and the development of market introduction strategies. It becomes apparent from these and other activities regarding

¹<http://www.destatis.de>

²<http://www.visionzeroinitiative.com/en/>

³<http://www.visionzeroinitiative.com/en/Concept/Does-the-vision-zero-work/>

⁵<http://www.prevent-ip.org>

vehicle safety that improving active safety systems is a very important goal for the car industry and governments with a potentially big impact on society by means of safer and more comfortable driving. Not only could optimized active safety systems help reduce the amount and severity of collisions and their consequences, but also improve a vehicle manufacturer's reputation with respect to vehicle safety. First attempts have been made to measure the quality of active safety systems¹, and it can be expected that more tests of that kind will find the public's attention and influence public opinion about the safety of the vehicles, also affecting the respective companies' reputation.

Among other strategies aimed at optimizing the performance of assistance systems, such as the fusion of different range sensors with individual strengths and weaknesses or the development of more powerful actuators (steering wheels, brakes), a more detailed understanding of the driving situation could help improve the performance of a driver assistance system. If a system is capable of adapting its behavior to the current situation, it can potentially provide a better assistance than if only limited information concerning the situation is available. To give an example, a driver assistance system that informs the driver about a slower moving vehicle ahead could modify its activation strategy if it knew that it is raining, a state that causes reduced visibility and a longer braking distance. Other useful sources of information that could increase situation awareness include navigation systems, car-to-car and car-to-infrastructure communication or the detection of darkness as measured by a sensor or inferred from the driver's use of the headlights, to name only a few.

A potentially substantial enhancement of situation awareness could be achieved through a better understanding of the driver himself. A variety of assistance systems, examples are discussed in section 1.4, could profit from information concerning the driver. As a matter of fact, some currently available systems infer the driver's state or intentions by analyzing his behavior and use that information in the system's activation strategy. Especially in the area of active safety systems, the driver and his behavior play a central role. Most collisions are caused by errors that have their origin in erroneous behavior by the driver (or drivers) involved in the situation. Based on an In Depth study of vehicle collisions carried out in the US in 1999, more than 70 % of the rear-end collisions recorded each year in the US are caused by distracted or inattentive drivers [2]. This finding is corroborated by results of the 'Naturalistic Driving Study', a large

¹<http://www.autobild.de/artikel/adac-testet-notbremsassistenten-1738340.html>

1. INTRODUCTION

field study conducted in the USA [3], which stated that about 80 % of the collisions that occurred during the study were caused by distraction. Detecting the state of the driver, either explicitly or implicitly through the divergence between critical and normal behavior, could hence provide valuable information for the activation strategy of active safety systems.

However, as will be discussed in more detail in section 5.1, current active safety algorithms use no or only limited information about the driver in their decision process. As will be shown on a number of occasions throughout the thesis, it is even advantageous to model a driver individually as opposed to describing human behavior in general terms, since drivers can vary substantially in their behavior. Recognizing and assisting in the correction of erroneous or potentially critical behavior by an individual driver could hence be a very useful way for the optimization of active safety systems. That driver-based optimization could affect two central criteria that are relevant for the success of active safety systems, effectiveness and user acceptance. Knowledge about the driver's driving skills and behavior in potentially critical situations could be used to adapt the activation strategy of such a system. This could in some cases lead to higher effectiveness, for instance through a temporal shift in the activation time of an autonomous brake for conservative drivers, who might not have the necessary skills to react in the face of an impending collision. In others, especially but not exclusively for highly skilled drivers, the user acceptance could be increased by the modification of the activation strategy of a system that informs the driver in case of a potentially critical situation, which could in some cases annoy the driver and lead to the deactivation of the system.

These adaptations of activation strategies of active safety systems require that there be differences between drivers. That these differences do in fact exist can for instance be observed in the following experiment studying the subjective criticality of lane changes. Fig. 1.2 shows the individual differences in the assessment of the criticality of a lane change situation reported by Honda, as mentioned in Winner's book [4]. In this study, a driver performed lane changes with varying distances and relative velocities with respect to a leading vehicle. The participants of the study were asked to rate the criticality of the maneuver. Even though all drivers felt considerable danger when the Time To Collision (TTC) was one second at the time the lane change was initiated, the subjective criticality of the maneuver changes considerably with increasing values for the TTC.

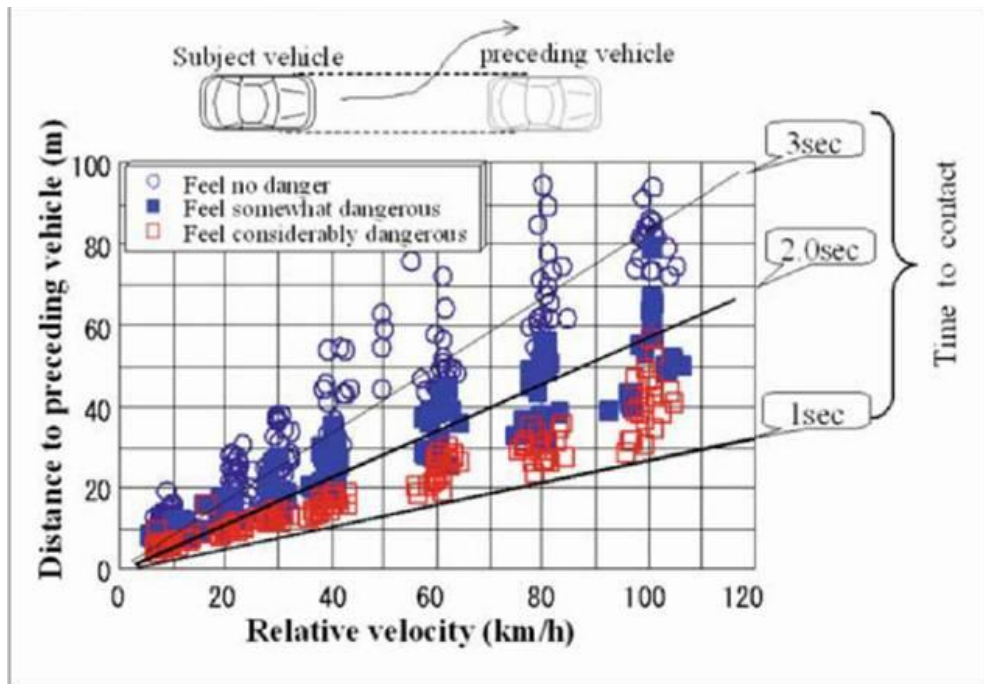

Figure 1.2: Subjective criticality of lane-change maneuvers, taken from [4]

Some drivers felt only somewhat endangered at TTC values of 1.5 seconds, while others still felt considerably threatened at TTC values as high as 2 seconds. The same effect can be observed at higher TTC values, some people still felt somewhat threatened at TTC values of 3 seconds while others felt no danger at all at around 2.5 seconds. The effect of individual differences on user acceptance, for instance, can be illustrated by a hypothetical safety system that informs the driver acoustically about an impending collision at a TTC of 2.5 seconds. Many of the studied drivers would presumably accept this information, because they felt somewhat threatened by the situation and would themselves try to avoid it, whereas others felt no threat and might be irritated by the acoustic signal. Another example for individual differences in criticality assessment using data from the studies carried out in this thesis is discussed in sections 5.2.2 and 5.3.2.

The main questions are how and what kind of knowledge about the driver could be used in the optimization of driver assistance systems, especially in the context of active safety systems, and how that knowledge could be acquired. The field of

1. INTRODUCTION

research engaged in the description of the driver and his driving behavior is called driver modeling. Sections 1.2 and 1.3 provide an overview of the research area, followed by an introduction to ADAS in section 1.4, including examples of how driver modeling could be used in the context of situation awareness for some of those systems. Among all the possible types of driver modeling that could be used to expand situation awareness, one is chosen in this thesis to study the benefit of driver modeling for active safety systems. The motivations behind the particular choice are discussed in section 1.5.

1.2 The history of driver modeling

The central goal of driver modeling is, as the name suggests, to build a model of human behavior with respect to the task of driving a vehicle. There is a consensus that there is no, and cannot exist, a single driver model that satisfies each and every requirement for all applications (see [5]). Rather, highly specific driver models with varying levels of complexity have been developed for each individual application. Driver modeling is a very broad field and work has been done in a variety of research areas for the past 60 years. An excellent overview can be found in the summary paper [6]. The authors split the research activities into four classes, which to some extent can also be seen as a temporal development of the field of driver modeling, fueled by increasing vehicle complexity and computational power:

- **Focus on the vehicle.** The main interest lies in the design of the vehicle. In this case the driver model usually serves as part of the closed loop testing of vehicle performance under varying driving conditions.
- **Focus on the driver.** In this case the attention lies on the driver himself. This includes efforts to model aspects such as driving style, path and route planning or psychological states while driving, such as stress or distraction.
- **Focus on the vehicle/driver combination.** The combination of the two aforementioned areas, specifically the interaction between driver and vehicle, is the main concern in application areas such as accident reconstruction or, with increasing importance, assistant systems. In the latter the focus lies on the driver's response to events triggered by the system.

- **Focus on the environment/traffic.** In macroscopic traffic simulations different models of driving behavior are used to simulate traffic conditions, which lead to a better understanding of how such conditions arise. One of the main goals is to identify negative traffic conditions and find countermeasures for them.

The authors then proceed to present each of these application areas in more detail, providing examples of typical driver models. In continuation, a brief summary of approaches described there, as well as contributions from other sources, is presented. Due to its importance in the context of this thesis, a more detailed description of the area focusing on the driver is presented in section 1.3 and chapter 2. As was motivated in section 1.1, understanding the driver could potentially be used to optimize ADAS, which is one the goals of this thesis.

1.2.1 Driver models focusing on the vehicle

Driver modeling with focus on the vehicle usually is the task of developing mathematical models of a control system. The earliest attempts at including some form of mathematical driver models in automotive development took place as early as the 1950's. One of the first researchers to investigate driver modeling in this context was Kondo in 1953 [7]. Based on a 2-wheel vehicle model, the aim of the driver model was to reduce a lateral offset between the current and desired trajectory Δy_p a distance L ahead of the vehicle. Fig. 1.3 displays the driver model. This is an example of a

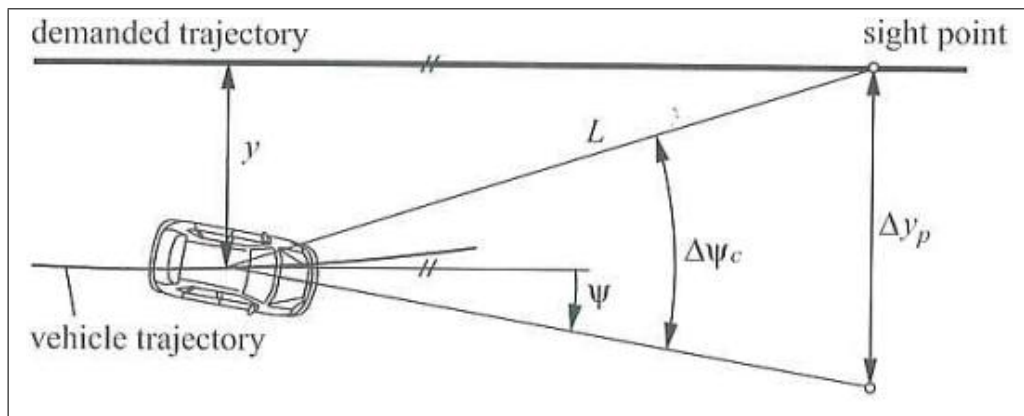

Figure 1.3: Kondo's driver model, taken from [6]

1. INTRODUCTION

driver model aimed at controlling the lateral motion of the vehicle. Longitudinal control has also received much attention, especially in the context of car-following, where a vehicle tries to maintain a certain distance to a leading vehicle, reacting to changes in the leading vehicle's velocity. Fig. 1.4 shows the situation and relevant variables involved. The most influential model of that kind was developed by Chandler et. al [9]

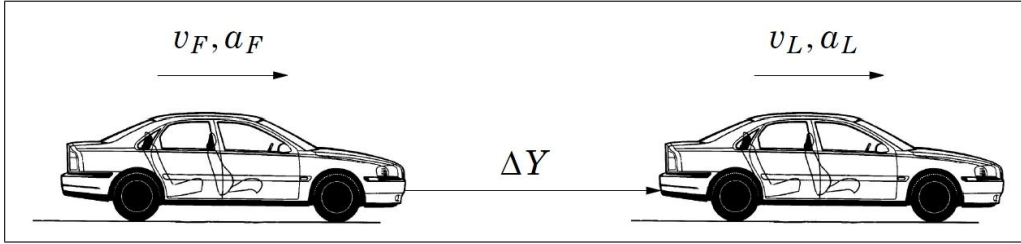

Figure 1.4: Description of the car-following situation, taken from [8]

in 1958. Since the work was done for General Motors, the model came to be known as the GM-Model. It is based on the stimulus-response relationship between the vehicles and can be expressed mathematically as

$$a_F(t) = \frac{\lambda}{M} [v_L(t - \tau) - v_F(t - \tau)] \quad (1.1)$$

where

- $a_F(t)$ = acceleration of the following car
- λ = sensitivity factor of the control mechanism
- M = vehicle mass
- v_L = velocity of the leader car
- v_F = velocity of the following car
- t = time of observation
- τ = reaction time

The values for the parameters λ and τ were estimated based on a small field study with eight participants. The value for sensitivity was set to $\lambda = \frac{0.37}{s}$ and the reaction time found to be $\tau = 1.5s$. Several improvements were developed based on the GM-Model, for instance by making λ dependent on the distance ΔY between the vehicles [10] or

elaborating a nonlinear model, in which the response is inversely proportional to the spacing [11].

Even today the term driver model, when no context is given, usually means the type of modeling presented above. The main purpose is to navigate a vehicle through a given scenario by adjusting steering wheel, accelerator and brake pedals appropriately. This way the vehicle's behavior in a variety of situations can be analyzed in a closed loop simulation before running costly and cumbersome tests using real vehicles and human drivers. Since the focus lies on the design of the vehicle, it is of no essential importance for the models to actually exhibit any human behavior at all.

Certainly, those that do have human properties are better suited for a variety of test cases, where no simple 'robotic' model is able to generate that kind of vehicle behavior that results from human features, such as errors in distal perception. A few mathematical models have been proposed that do include these human factors. Leutzbach [12] introduced the psychological concepts of 'perception threshold' to cope with the fact that drivers do not follow cars at large distance and can not clearly perceive small difference in relative speeds or speed differences. Based on this concept, Leutzbach and Wiedermann [13] presented a model of the relative speed or speed difference, the perception limits with respect to small relative speeds and changes in headway distance. Brackstone et al. [14] attempted to calibrate those psychological thresholds using data collected from UK motorways, but those parameters have not been validated by real observation.

1.2.2 Driver models focusing on vehicle/driver combination

In recent years the interaction between driver and vehicle has received increasing attention in automotive research. One of the main reasons is doubtlessly the rise of advanced driver assistance systems in modern vehicles. All of these systems communicate with the driver in some way, either by actively intervening in vehicle dynamics, like braking, or by stimulating human sensory channels, for instance through visual or auditory warnings. How human beings react to these interventions is of vital importance, and can be decisive for the commercial success or failure of a given system. One large study investigating how an Automated Cruise Control (ACC) system affects driving behavior is presented in [15]. The study showed that the participants were able to learn to use the system effectively within a few hours, reducing the mental workload involved

1. INTRODUCTION

in driving a vehicle. However, one problem observed by the authors was the strong braking many participants performed to deactivate the ACC and return to unassisted driving. Such effects have to be considered when designing a system that interacts with the driver.

Here again, driver models in the mathematical sense described above are potentially useful to test the system in simulation before running tests in the field. However, in general, the driver models need to be more complex than the mathematical control models, since at least some aspects of human cognition need to be considered. For instance, for a hypothetical assistance system that steers the vehicle away from an obstacle, it is necessary to take the driver's reaction to the steering into account. This reaction is influenced by various human states, such as distraction, stress level or general driving skill. Human factors need to be considered in the driver model to some extent if the model is to help in the design of such a system. Apetaur and Opicka [16] for instance estimate the effort the driver needs to exert in selected driving maneuvers. Another study investigating the effect that ACC has on driving behavior was carried out by Ohno [17]. To account for differences in driving skill, a driver model based on a neural network was implemented. This driver model was then used to predict the control performance of a skilled driver when using ACC.

1.2.3 Driver models focusing on environment/traffic

The parallel increase in computational power and number of vehicles on the streets has lead researchers to study traffic as a closed system on a macroscopic scale. The main goal is to understand how certain traffic situations emerge and how undesirable ones can be prevented. These macroscopic models need a microscopic description of how vehicles interact, for instance in car-following situations. Questions concerning traffic events, such as car-following, need information about driver properties, which again leads to the kind of driver modeling discussed in this section. Models of vehicle interaction are related to the mathematical models presented above. The main difference between those models and the driver models used in traffic simulation is the level of granularity on which the models operate. The methods with the focus on vehicle development usually pay special attention to the physical properties of the vehicle and use detailed mathematical models of vehicle dynamics. The microscopic traffic models on the other hand are not interested in such detailed representation of vehicle dynamics, but rather

model the reaction of vehicles (or more precisely, drivers), to conditions arising due to the interaction with other vehicles in the vicinity.

In order for situations to emerge in a traffic simulation that resemble those found in real traffic, the driving behavior needs to resemble that of real driving as closely as possible. Early attempts modeled only very simple behaviors, such as the car-following GM-model [9]. These only accounted for a very limited number of human factors, in the case of the GM-model a sensitivity factor and the driver's reaction time. More complex models have been implemented that model the different levels involved in driving a vehicle (see section 1.3), making the behavior and hence the simulation more realistic [18].

Traffic simulations can also be used to analyze specific, previously defined scenarios. One example for a traffic situation where traffic simulations provide valuable information is that of a bottleneck. A bottleneck exists whenever one or more lanes end due to a blocked road, forcing the vehicles to change lanes, increasing traffic density. Such a situation on a highway was investigated by Kerner et al. [19]. A similar scenario is platooning, where a number of vehicles follow a single leader at a close range. If the first vehicle needs to brake suddenly, this behavior is passed through the chain. The danger in this situation is that each of the following vehicles has less time to react than its preceding vehicle, leading to a collision at one point of the chain. For the simulation of this situation, car-following models that exhibit a certain amount of human behavior, for instance reaction times, need to be integrated into the traffic simulation.

The impact of advanced assistance systems, such as ACC, on traffic flow and driver behavior have received increasing attention in recent times and deserve a special mention. VanderWerf et al. studied the effect of ACC on traffic flow dynamics and capacity using mathematical models in a simulation environment where vehicles with and without ACC interacted in a limited space [20]. The authors from the study concerning ACC mentioned above [15] studied how the implemented ACC system affected the driving behavior of 108 individuals. Among other results the study showed that the ACC system lead to larger headways for many drivers and, as a consequence, safer driving. This can in turn be included in a traffic simulation software to predict the effect of ACC on traffic in general, as done by Bareket and colleagues [21], and on special conditions such as the above mentioned bottleneck.

1.3 Driver models focusing on the driver

As could be seen in the previous section, the term driver model stands for very different things depending on the context. Driver models can be as different as complex mathematical control models, psychological models or simple stimulus-response models for traffic simulation. The goal of this section is to define what driver modeling means in the context of this work. In their summary paper [6], Plöchl and Edelmann divide the research area interested in the understanding of human driving behavior into two clusters:

- Understanding driver and (individual) driver behavior
- Path and speed planning, optimized driver/driving behavior

The first cluster is concerned mostly with modeling how we perform the task of driving a vehicle. One central aspect is the modeling of how drivers behave on the level of individual maneuvers, which is the type of driver modeling studied in this thesis. Knowledge of how (individual) drivers perform certain driving tasks can be used to predict driving behavior. A definition of the term driving maneuver is found in section 2.1. To name an example, one of the maneuvers that has received a lot of attention over the years is the car-following behavior on highways. The main goal of most of these works is to develop ACC systems that exhibit similarity in behavior to that of humans. As was already mentioned above, Chandler and colleagues [9] were among the first to implement a car-following model and used data from experiments with real vehicles to set the model's parameters. Ioannou [22] implemented an ACC system and compared it to three different human driver models. The results were that the ACC system was able to smoothen traffic flow and even lead to a safer driving. Germann [23] implemented a hybrid three-layered ACC system based on fuzzy logic and neural networks.

Other examples of maneuvers that have been studied include emergency braking ([24],[25]), lane change ([26], [27]), and turning at intersections ([28],[29]). Predicting the driver's intention could provide valuable information in the context of ADAS, as will be discussed in section 1.4. An example for a prototypical emergency braking algorithm that includes the prediction of driving maneuvers in its decision process is presented in

chapter 5. A more detailed overview of methods whose goal is the prediction of driving maneuvers is given in chapter 2.

Apart from predicting driving maneuvers, other human factors that are relevant for the task of driving have been studied. Three of the factors that have received the most attention are

- Sleepiness
- Distraction
- Emotional states

A number of methods have been implemented that try to assess the driver's sleepiness. Most of them rely on direct observation of the driver's face through video cameras and use eye ([30],[31],[32]), eyelid ([30],[33]) or head movements ([34][30],[32]) to infer sleepiness. A few indirect algorithms, usually using steering behavior in the context of lane keeping ([35],[33]), have also been developed.

Detecting that a driver is distracted is also a potentially very useful information, since in that case the driver may not be aware of a dangerous situation. As was previously mentioned, the 'Naturalistic Driving Study' came to the conclusion that about 80% of the collisions were caused by distraction. As with the detection of sleepiness, the main source of data for this purpose is a video camera capturing the driver's upper body ([36],[37],[38]). Other sources of information that can distract the driver are cell-phone usage [39] and the on-board information systems such as radio or navigation systems [40].

The driver's emotional states, most prominently stress or anger, are very difficult to measure. The most promising approach is to evaluate physiological data like heart rate [41] or blood pressure [42]. The difficulty, however, is how to obtain that information. Algorithms exist that estimate the heart rate from video images, but blood pressure or electrodermal activity need skin contact, for instance through special sensors located on the steering wheel. Speech has also been used as an indicator for emotional states ([43],[44]). How environmental factors, such as waiting times at intersections or road curvatures, influence emotions and how this can be modeled using fuzzy logic was studied in [45].

1. INTRODUCTION

The second cluster deals with driver intention on a larger timescale than single maneuvers. The goal of driver models on this level is to calculate an (optimal) path. One classic example is the ISO lane-change, which constitutes not only of changing the lane to pass a preceding vehicle, but to join the original lane afterwards. Some methods have been implemented that predict the driver's choice of the next segment on a digital map based on the current behavior ([46],[47]).

On an even larger timescale, the task can be to optimize navigation based on strategies that consider a sequence of road elements. The purpose could for instance be the optimization of a driver model for a race track. Jürgensohn [5] implemented a fuzzy controller for the longitudinal control of a vehicle (Confuzzius) that had to complete a test course using four different strategies

- **A1:** Drive fast without leaving the road.
- **A2:** Drive fast but safe.
- **A3:** Drive comfortably.
- **A4:** Drive emphatically safe.

Fig. 1.5 displays the velocity profile over the length of the course of a human test driver (a) in a driving simulator and the fuzzy controller (b) under the four above mentioned conditions.

Michon [48] provides a widely accepted classification of human driving. He partitions the task of driving a vehicle into three layers, depending on duration:

1. **Strategic level:** In this level the driver does path planning on a temporal scale ranging from a few minutes to many hours. The decision is influenced by factors such as distance, cost or aesthetic value of the chosen route.
2. **Tactical level:** This is the level that deals with single maneuvers, such as lane-changing and turning, which usually take a few seconds, with some exceptions such as car-following. This level corresponds to the first group in Plöchl's categorization.

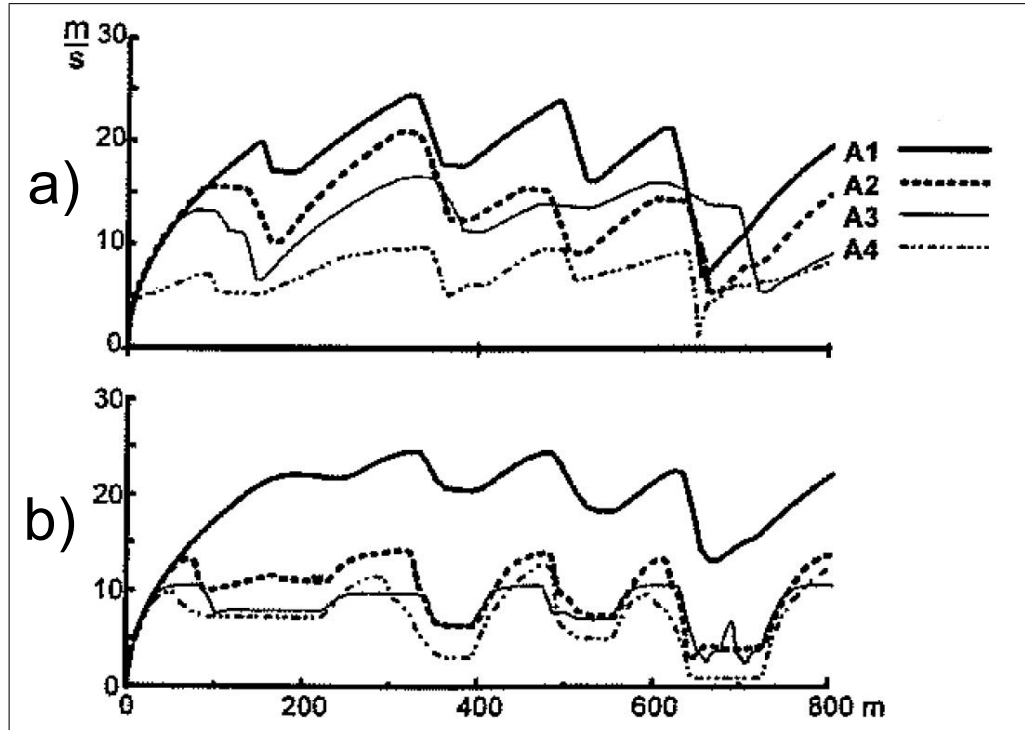

Figure 1.5: Velocity profiles for a race course, adapted from [5]

3. **Control level:** Actions on this level generally take less than a second and are performed to carry out the maneuvers from the previous level. Human decisions are in general made consciously on the tactical level and subconsciously on the control level.

Examples for driver models on the control level can be found in section 1.2.1. Publications describing driver models on the strategic levels are less numerous, two examples that were already mentioned are [46] and [47]. The method developed in this thesis operates on the tactical level, specifically the (driver dependent) prediction of driving maneuvers. In continuation, whenever driver modeling is mentioned in this thesis, it is employed in the context of the prediction of driving maneuvers, unless otherwise stated. Examples for driver models on the tactical level have already been mentioned in this section. Since it is the main topic of the thesis, a detailed discussion of approaches predicting driving behavior on the tactical level are also presented in the next chapter.

1.4 Advanced driver assistance systems

In this thesis, and in most publications on driver modeling in the last years, the target of driver modeling is the development of an advanced driver assistance system, either for validation or optimization purposes. In order to understand how driver modeling can affect the development of these systems, it is important to understand what ADAS are. In this section, an overview of advanced driver assistance systems is given, coupled with how driver models focusing on the driver could influence the systems' behavior.

In general, ADAS are designed to help the driver in his driving process. There are many different ways how this can be achieved, leading to a large number of available products with varying complexity. Each of them make use of information from a variety of sources, as for instance the vehicle itself (the vehicle's velocity, steering angle, etc.), a navigation system or sensors that detect obstacles in the environment. For a systematic overview, this large number of systems has to be divided into meaningful groups. This division can be done in a number of ways, from which a very popular one is discussed here. Due to the complexity of the field, the boundaries of the individual clusters are not strict, many of the systems presented exhibit characteristics from more than one class. In this classification, ADAS are separated into four groups, depending on the level of automation.

- Driver information systems
- Comfort systems
- Semiautonomous systems
- Autonomous systems

This classification is appealing for two main reasons. Firstly, it classifies the systems into classes with increasing complexity. In general, the more autonomous a system is, the higher the requirements for environmental sensors and algorithms that analyze the current situation. Increasing involvement in the driving task also requires more sophisticated and extensive testing procedures. A system that is designed to, as an example, perform an autonomous emergency brake has to be tested much more thoroughly than a similar system which emits an auditory warning in the same situation. Secondly, and as a consequence of the above, this classification also draws a good picture of the

historical development of ADAS, since the easier a system is to implement and test, the quicker it is bound to appear on the market. Each of the groups is explained in more detail, providing examples of systems currently available in commercial vehicles or concepts that are targets of ongoing research. For each category, sample types of systems where driver modeling could be used in the optimization process are presented. It is not suggested by these examples, however, that available systems of the respective type do not already include some kind of driver modeling, nor that driver modeling has no benefit for any other assistance system where a potential usefulness is not explicitly mentioned here.

1.4.1 Driver information systems

Driver information systems provide information to the driver that support him in the driving task without actively intervening in vehicle dynamics. This information is usually presented as auditory, visual and / or haptic stimuli. Examples of such systems are Lane Departure Warning (LDW) or Collision Warning (CW). LDW systems inform the driver if the vehicle is about to leave its current lane. These systems depend on the detection of the lane, which is achieved by evaluating data from video, laser or infrared sensors observing the area in front of the vehicle. Nowadays, many car manufacturers offer a LDW system or the more complex Lane Keeping Assist (LKA) system, which is presented in section 1.4.2. The goal of CW systems is to inform the driver in the case of an impending collision. In most cases, this driver information is only the first in a chain of assistance methods, culminating in a partial or full operation of the vehicle's brake in the case of a failing or insufficient response from the driver. An example for such a chain published by Mercedes Benz¹ in 2008 is depicted in Fig. 1.6. Both could profit from models describing the driver and his behavior. LDW systems for instance could use information about how drivers usually perform lane changes, inhibiting the activation of the system if a lane change is predicted. In the case of CW, the detection and prediction of driving maneuvers such as car-following or lane changes could also lead to a modification of the activation strategy. In both of the above examples, the detection of the driver's sleepiness or distraction also provide valuable sources of information for a situation-specific system design.

¹http://www.mercedesbenz.com/Nov08/12_001507_Mercedes-Benz_TecDay_Special_Feature_PRE_SAFE_And_PRE_SAFE_Brake.html

1. INTRODUCTION

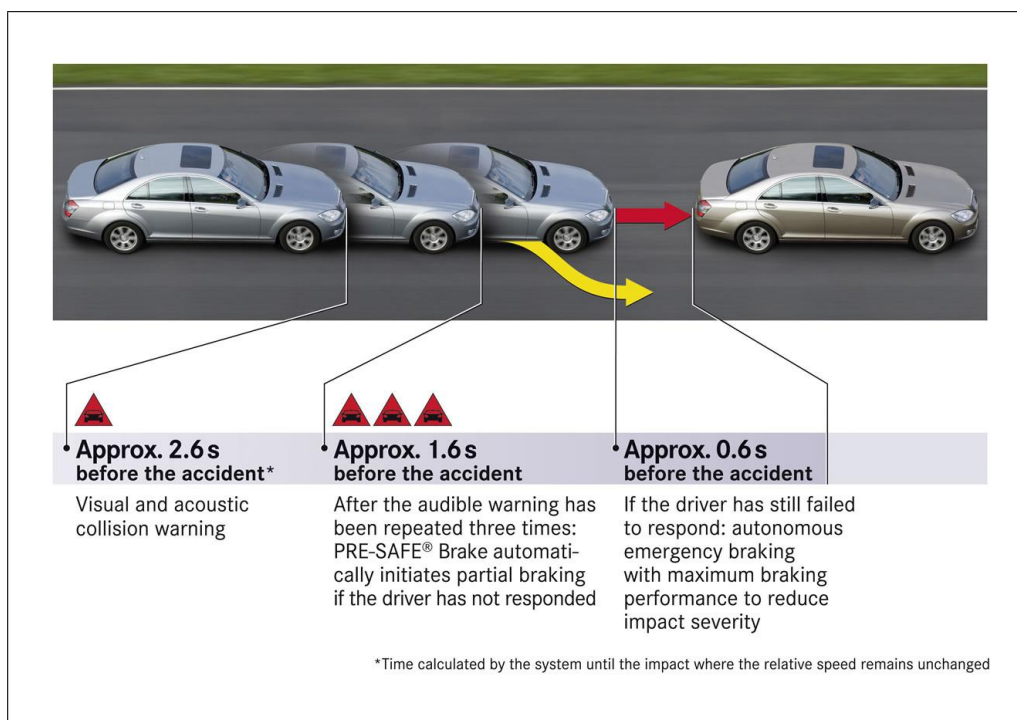

Figure 1.6: Activation chain of a Collision Warning / Collision Mitigation system

Detecting the driver's fatigue level is an essential part of Drowsiness Detection (DD) systems. These detect when a driver's attentiveness is reduced, usually from long periods of driving, and suggest a break. It is one of the examples where the study of driving behavior has been an integral part of a development leading to commercially available products. Park Assist (PA) systems, on the other hand, constitute an example where driver modeling does not provide additional information. PA systems detect obstacles within a close range of the vehicle. This information is transmitted to the driver, usually through auditory signals, and used by the driver to estimate if the current vehicle trajectory is safe. They are generally designed to become activate if the vehicle's velocity is below a certain threshold, regardless of the intention of the driver. Detecting the driver's intention or other human factors is not relevant in that situation.

1.4.2 Comfort systems

Comfort systems are designed to help the driver in frequent driving situations by taking over a very limited part of the vehicle's control. Systems of this type include ACC,

1.4 Advanced driver assistance systems

Lane Keeping Assist (LKA) or Active Steering (AS). The best known example from this category is ACC, which adjusts the speed of the vehicle according to the current driving situation to keep a desired distance from a preceding vehicle. LKA systems go one step further than the LDW systems presented above. Instead of informing the driver about an impending lane crossing, they actively apply a small force on the steering wheel to delay the lane crossing or, in the case of curves with a big radius or small lateral movements on a straight road, avoid it altogether. These two types of assistance systems could profit from models describing how drivers perform the maneuvers that are relevant to the system, car-following in the case of ACC and lane changes for LKA. For ACC, closing in on the leading vehicle in a way that resembles the driver's own behavior could improve consumer acceptance. The prediction of lane changes could have the same effect for LKA systems. A driver could get irritated if he wants to perform a lane change and the system does not recognize it, countering the steering maneuver with the intention of staying in the center of the lane.

Active Steering¹ is another example for a comfort system. It changes how much the wheels turn in response to the driver turning the steering wheel at different speeds. The higher the speed of the vehicle, the more the driver has to turn the steering wheel to reach a desired wheel angle. This is useful in parking situations, where a small moment on the steering is enough to reach the wheel's limits. In high speed situations, on the other hand, the high steering ratio leads to improved directional stability. In the case of AS, and in vehicle design in general, driver-specific preferences for how the angles of the wheels change in response to a modification in steering wheel position, could help optimize the driving comfort for the individual driver.

1.4.3 Semi-autonomous systems

Semi-autonomous systems assist the driver in carrying out complex maneuvers by taking over the control of the vehicle under specific circumstances. The main difference between semi-autonomous and autonomous systems is that in the former the responsibility still lies in the hands of the human driver, whereas in the autonomous case the system takes over the responsibility for the vehicle's safety as far as it can be influenced by the system. Intelligent Park Assist (IPA) systems are one example of

¹http://www.bmw.com/com/en/insights/technology/technology_guide/articles/mm_active_steering.html

1. INTRODUCTION

semi-autonomous systems. As opposed to PA systems that only inform the driver while parking, IPA systems partially take over control of the steering wheel. Here again, knowledge about the driver does not add any relevant information the system could benefit from.

In order to avoid collisions or decrease the collision speed, a variety of Brake Assist (BA) techniques have been developed. These systems perform an emergency brake in the case of an impending collision detected by a sensor covering the front of the vehicle. Regardless of the criticality of the situation, the driver needs to apply a certain amount of force on the brake himself before the system is activated. A variation of BA, that does not depend on range sensors, detects the speed with which the driver applies the brake, deduces that the driver attempts an emergency brake, and performs the emergency brake itself. This last is another example where driver modeling, in this case a model recognizing emergency brake behavior, provides valuable information for the development of a system.

Except for parking, no semi-autonomous system that assists the driver with steering maneuvers has reached a sufficiently advanced state required for the successful integration into commercial vehicles. Emergency Steer Assist (ESA) systems are currently being investigated¹. The idea behind ESA is similar to that of BA, with the difference that the system amplifies or reduces the amount of steering administered by the driver. The goal is to follow an optimal evasive path without losing control of the vehicle. However, the initial steering maneuver has to come from the driver, only then does the system intervene. Driver models predicting the driver's intention of performing such an evasive maneuver could provide valuable information for these systems in order to find the optimal intervention strategy.

1.4.4 Autonomous systems

Autonomous systems, as the name suggests, control the vehicle in specific situations without any input from the driver. Since they carry the full responsibility for their actions, these systems have to fulfill very strict functional requirements. Due to these requirements, they need to be very certain about the current state the vehicle is in,

¹http://www.conti-online.com/generator/www/com/en/continental/pressportal/themes/press_releases/3_automotive_group/chassis_safety/press_releases/pr_2010_06_14_esa_en.html

1.4 Advanced driver assistance systems

which requires complex situation sensing and analysis methods. As a consequence, only very few autonomous systems have reached commercial status. The goal of autonomous systems is, one day, to have a fully autonomous vehicle that is at least as safe as any human driver.

The Antilock Braking System (ABS) was the first assistance system to be introduced in commercial vehicles¹. This system makes the vehicle stay on track during a braking maneuver, even under adverse conditions like icy or wet roads. This is done by adjusting the hydraulic brake pressure at each wheel (or front and rear wheels) separately. A similar autonomous system is the Electronic Stability Program (ESP), which stabilizes the vehicle in lateral direction. By measuring the difference between the driver's steering and the vehicle's driving direction through special ESP sensors, a potential skidding situation can be detected. The skidding is prevented by braking or accelerating the driving wheels, keeping the vehicle in a stable state. Since both operate on the control level, require very limited information of the environment and do not require strong interventions, it was possible to include these systems in commercial vehicles before any other assistance systems reached production level.

The only truly autonomous systems currently available in commercial vehicles except for the two mentioned above are the active safety systems Collision Mitigation (CM) / Collision Avoidance (CA). In the last years, a number of autonomous CM systems that perform autonomous brake activations have been introduced in the market. Due to the dangers faced when activating an emergency brake, most of these systems either do not provide full braking power or are activated very late in order to limit the risk. It is difficult to distinguish between the two types of systems, since it is not always possible for CA systems to avoid a collision. In general, currently available products are designed to mitigate collisions and are therefore considered CM systems. One example is the emergency brake activation from the intervention strategy depicted in Fig. 1.6. Some of these systems are designed to avoid a collision under certain circumstances, for instance in city traffic with velocities of at most 30 km/h². The main goal in those cases is to avoid fender benders and accidents with pedestrians in city traffic. As was motivated in section 1.1, CM systems are among those systems that could profit from driver modeling. The detection of fatigue, distraction or stress and the prediction of

¹<http://www.bosch.com/assets/en/company/innovation/theme03.htm>

²www.volvocars.com/us/all-cars/volvo-xc60/pages/5-things.aspx

1. INTRODUCTION

driving maneuvers are among the areas of driver modeling that could be used in the development of CM systems. From among the available options, the prediction of driving maneuvers was chosen as the focus of this thesis, a choice for which the reasons are presented in the following section.

1.5 Driver modeling and active safety systems

In the course of this chapter, an overview of both driver modeling and ADAS was given. It has already been mentioned that driver assistance systems could benefit from the information provided by driver models in their analysis of the situation. Some examples for assistance systems were given where driver modeling plays a central role, for instance Drowsiness Detection. In most of those ADAS that could potentially profit from driver modeling, the prediction of driving maneuvers is among the viable options. Hence, a method for predicting driving behavior on the tactical level could potentially be relevant for a number of different assistance systems.

Active safety systems, such as CW or CM, are among those ADAS where driving maneuver prediction could enhance the situation awareness and consequently effectiveness and consumer acceptance. From the results of the study by Honda depicted in Fig. 1.2 it was argued that the hypothetical CW system suggested there could have low acceptance values for drivers who did not feel threatened at the time the acoustic information would have been triggered. The prediction of lane changes, for instance, could be used to prevent informing those drivers for whom narrow lane changes are part of their regular driving behavior. For other drivers, on the other hand, driving maneuver prediction could increase the effectiveness of a CM or CW system. Using again the study by Honda as an example, drivers who felt considerable danger at a TTC of, for instance, 1.5 seconds would never voluntarily get involved in such a situation and could need assistance to avoid or reduce the severity of a collision.

As was mentioned before, faulty behavior by the driver is a major reason for vehicle collisions. In the In Depth analysis [2] mentioned in section 1.1, the driver response to a critical situation was analyzed based on rear-end collisions that had a high injury rate and where a CW system could have provided assistance, had it been available in the vehicle. Table 1.1 shows the percentage of the different types of reactions in the following three studied types of critical situations:

Reaction	Type 1	Type 2	Type 3
None	81.4 %	78.4 %	83.8 %
Braking	12.2 %	15.5 %	8.1 %
Steering	1.1 %	2.2 %	1.7 %
Other	-	-	-

Table 1.1: Driver reaction in severe longitudinal collisions, taken from [2]

1. **Target decelerating.** Both vehicles drive with constant speed and the leading vehicle decelerates.
2. **Target stationary.** The vehicle drives with constant speed and collides with a standing vehicle.
3. **Target constant.** Both vehicles drive with constant speed and the leading vehicle is slower.

These are highly relevant scenarios for rear-end collisions, as will be discussed further in chapter 5. Hence, providing assistance in those cases can greatly improve the driver’s safety. Only very few of the drivers attempted to avoid the collision by braking or steering, more than three quarters did not react at all to the impending danger. A model predicting the driver’s lane changing and braking behavior could aid in the detection of these situations that exceeded regular driving behavior and where no action with the intention of avoiding the collision was observed. Depending on the regular braking and steering behavior, a CM system could adapt its behavior in the face of such a lack of response from the driver. One of the advantages of that approach is that the source of the unusual behavior need not be known. It is not important whether the critical situation arose from fatigue, distraction or any other source of erroneous behavior, which would be the focus of attention of other driver modeling methods. Hence, abnormality detection through maneuver prediction is a very general approach, which does rely only on the difference between regular and unusual behavior.

The question that remains is whether it is possible to distinguish between normal and abnormal behavior early enough prior to a collision to be of any benefit. If abnormal behavior can only be detected shortly after a collision takes place, then no CM system would profit from that information. This is not the case, as can be seen in Honda’s

1. INTRODUCTION

study regarding the subjective criticality of a lane change situation. In that study, all participants felt a considerable danger at TTC values between 1.0 and 1.5 seconds, and many even at TTC values of around 2.0 seconds. This indicates that none of the drivers would have performed a lane change in these situations. However, a TTC of for instance 1.5 seconds, which would count as abnormal for many drivers, is still high compared to the activation times of current emergency braking algorithms, as will be discussed further in section 5.1. Hence, for a large number of those drivers who did not react in the In Depth study, a detection of an abnormal situation could have potentially been very useful for improving the effectiveness of a CM system. The generality of maneuver prediction for abnormality detection, together with its potential usefulness in other areas of ADAS, were the main reasons for choosing maneuver prediction over other driver modeling areas as the focus of this thesis.

In this thesis, a driver model capable of predicting driving behavior for the individual driver is presented. Using data collected during regular driving, a model based on fuzzy theory is generated, which is subsequently used to predict new maneuvers of the same kind. Since the method involves generating a maneuver prediction model, an overview of that area of driver modeling is presented in chapter 2, some examples of which were already mentioned in section 1.3. Following the overview, the driver-adaptive maneuver prediction model developed in this thesis is presented in chapter 3. Since the area of application are driver assistance systems, a number of criteria that need to be fulfilled by a driver model are defined. The method is evaluated in chapter 4 based on these criteria and other performance measures, using data collected in a field study and two inner-city maneuvers as test cases. The driver model is then used as part of a prototypical driver-adaptive active safety system. An autonomous braking algorithm is described in chapter 5, which uses a model of the driver's stopping behavior in its decision process. The algorithm performs an autonomous brake in the scenario defined as type 1 in table 1.1, if the situation is critical for the specific driver and no braking maneuver is predicted by the driver model. It is shown via a simulator study that the algorithm is capable of providing vital assistance to avoid or at least mitigate collisions in that specific scenario, without, given its driver-adaptive nature, causing any incorrect or premature activation of the autonomous brake, thus providing valuable assistance to the drivers who participated in the simulator study.

2

Driving maneuver prediction

As was mentioned in chapter 1, the goal of the driver model developed in this thesis is to predict driving maneuvers based on the driver's behavior. This chapter provides a detailed summary of driver models that have been developed in that context. Before discussing the methods, a definition of what constitutes a driving maneuver needs to be established. This is done in section 2.1, followed by an overview of the different types of driver models in section 2.2. Examples for the two main strategies for predicting driving maneuvers are then presented in sections 2.3 and 2.4.

2.1 Definitions of driving maneuvers

Even though the concept of a driving maneuver should be intuitively clear to most people, it becomes less apparent under close examination what a maneuver actually consists of as well as how many maneuvers exist. This is illustrated by the following small sample of German publications on the topic. Even though these classifications of driving maneuvers are based on traffic and road infrastructure found in Germany, they are more than adequate to illustrate the point. Examples for classifications that resemble those that intuitively come to mind when thinking about driving maneuvers are provided by Reichart [49] and Tölle [50], which are shown in table 2.1. These lists differ to a small degree, but they describe driving maneuvers on the same level of granularity. According to Tölle, the list he proposes is sufficient to fully recreate any trip taking place in city or rural areas as well as on highways, with the exception of unexpected changes in situation such as the sudden appearance of an obstacle. More

2. DRIVING MANEUVER PREDICTION

Reichart	Tölle
Follow lane	Start
React to obstacle	Follow
Turn at intersection	Approach vehicle
Cross intersection	Overtake vehicle
Turn into street	Cross intersection
Change lane	Change lane
Turn around	Turn at intersection
Drive backwards	Drive backwards
Choose velocity	Park
Follow vehicle	

Table 2.1: Lists of driving maneuvers, from [49] and [50]

lists similar to the ones shown above have been proposed, the differences in maneuvers depending mostly on the purpose of the application being studied. One example is the system driving autonomously on highways developed in [51], where those maneuvers taking place on highways are segmented in more detail.

It is difficult, however, to model the behavior of a driver based on the type of maneuvers suggested above, because human beings on that level of granularity carry out the same driving maneuver differently in different situations. Others therefore go one step further and partition maneuvers based for instance on direction (left turn is a different maneuver from right turn) or region (a lane change in a city is different from one taking place on highways). The level of detail can be increased further by introducing situational factors such as infrastructure (highways with different number of lanes), traffic (oncoming traffic, traffic flow) or weather (visibility, rain). Fastenmeier [52] for instance proposes a classification of the situation into 8 variables belonging to the classes road type, driving surface and traffic flow. Each of these variables has between 2 and 9 categories each, ending up with 3150 possible combinations. This is still considerably lower than the classification advanced by Von Benda [53], with a total number of 14 variables and up to 10 categories leading to a number of different situations of several millions.

It is not possible to consider millions of different maneuvers in practice. This is especially true for driver models where the maneuver type is to be predicted from

2.2 Overview of maneuver prediction models

sample data extracted while driving, as is the case for the driver model developed in this thesis. Clearly, segmenting the driving task into possibly millions of individual types of maneuvers does not provide enough examples for effective learning. For the purpose of predicting driving behavior the level of granularity of the maneuvers has to be such that the resulting model is neither too specific nor too general. For this work the following definition of a maneuver is proposed:

A maneuver is a tactical driving task such as stopping behind a vehicle, changing the lane or turning at an intersection. These maneuvers are differentiated by the situational factors type of road, speed limit, number of lanes and the existence of other vehicles, traffic signs or traffic lights ahead of the vehicle.

There are three types of road (inner city, rural and highway), up to three sufficiently distinct speed limits for each type, two types of lane (one or more lanes in direction of travel) and two classes each for the existence of leading vehicles, traffic signs or traffic lights. These factors combine to 144 possible types of maneuvers for each basic maneuver type (for instance a lane change). This is already a large number of different factors for a system designed to predict human behavior by learning from examples. In practice, however, only a limited subset of the situational factors are relevant for the modeling of a specific maneuver, which does provide enough sample maneuvers in normal driving activity from which to infer human driving behavior.

2.2 Overview of maneuver prediction models

Having defined what a maneuver is, it is essential to establish what a driver model is in the context of the prediction of those maneuvers. Predicting driving maneuvers is a challenging task, since it involves building a model of human behavior. Human behavior is influenced by a large number of internal and environmental factors, which ideally should be included in the model in order to provide a faithful representation. Such factors include, without any claim of completeness:

- emotional states such as stress or anger.
- physical conditions, e.g. motor skills or reaction times.
- environmental influences, e.g. bad weather, lighting or traffic conditions.

2. DRIVING MANEUVER PREDICTION

- cognitive capabilities like mental load, distraction or fatigue.
- Driving skills and human learning capabilities.
- Goals and motivations.
- Observable behavior.

A model that incorporates all of the aspects mentioned above is effectively a computational representation of the human being. This is of course highly complex and not yet feasible in practice. Consequently, methods that have been suggested in the literature focus on manageable subsets of these factors. Hopes are that some day a combination of specialized models may lead to a powerful metamodel capable of replicating human driving behavior in its full complexity. As Jürgensohn points out in his book on hybrid driver models [5], there can be no single model capable of representing the complexity of human behavior all by itself. In his opinion, a hybrid driver model can only work if it fulfills three requirements

1. **Heterogeneous structure.** No single computational model is capable of modeling the richness and complexity of human activity. Only the combination of specialized methods and tools will be able to achieve a good representation.
2. **External model validation.** The specialized models need to be supported by psychological and physiological research in order to be plausible and effective representations of human behavior.
3. **Problem-specific modeling.** Since there are no models that explain human behavior regardless of its context, the choice of the models as well as their implementation and parametrization are specific to the problem being investigated.

Jürgensohn suggests one simple hybrid driver model, consisting of a perception model based on artificial neural networks (see section 2.4.1) and a decision module modeled as a fuzzy logic controller (see sections 2.4.4 and 3.2). Another hybrid model aimed at providing realistic driving behavior in a traffic simulator is presented in [18]. The model consists of modules for the tactical and control levels of operation (see section 1.3). The tactical module decides which maneuvers to execute following a rule-based approach involving context evaluation, choice generation from among the available

maneuvers and a decision history. The control module carries out the chosen maneuver using basic hierarchical state machines such as *speed control* or *signalling*. Kiencke et al. implemented yet another hybrid driver model to be used in traffic simulation [54]. In their model, a velocity controller is extended through a perception module that addresses human deficiencies. Given this combined model, it is possible to model the deterioration of the driver's control performance when he reaches his personal limits.

Even though some models like the aforementioned have combined human psychological and behavioral properties, much of the driver modeling research has focused on one part or the other. Hence, they will be reviewed separately. There is the class of models, which will be labeled cognitive driver modeling, that try to model human behavior based on internal human factors like mental load or attention span. Models from this class set out to explain human behavior by looking at how the mind processes information, and to use this mental model in the reasoning process, which in this case is the execution of a driving maneuver. Models of the second category, which will be called behaviorist driver modeling, are those that observe measurable human behavior and try to infer intentions from it, with no or only very limited representation of internal states. Clearly, a combination of both paradigms is desirable, since together they allow for a much more complete and plausible representation of what actually happens in the task of driving.

2.3 Cognitive driver modeling

As stated above, cognitive driver models attempt to explain human behavior through the representation of human information processing. Human factors such as memory, learning or visual perception play a central role. These driver models are usually implemented in a cognitive architecture, such as Soar [55] or ACT-R [56], which provide a framework that enables the modeling of a wide variety of human cognitive processes. Since ACT-R is one of the most widely used architectures and the one that has received most attention in the driver modeling community, its basic principles are presented in continuation, along with references to their potential usefulness for driver modeling.

2. DRIVING MANEUVER PREDICTION

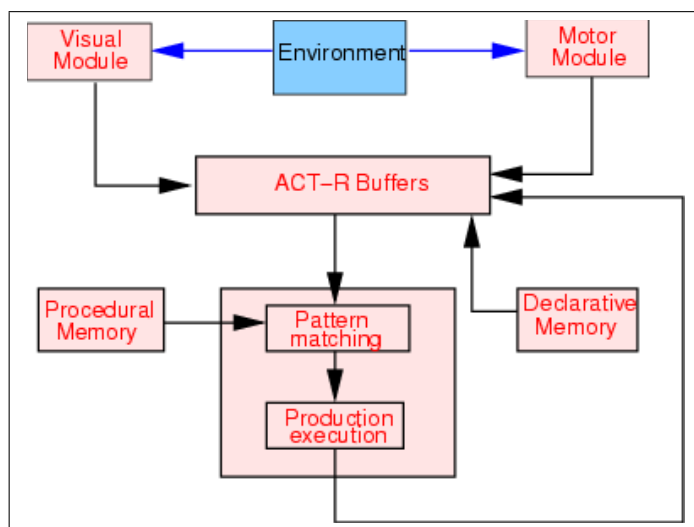

Figure 2.1: The architecture of ACT-R

The architecture of ACT-R is depicted in Fig. 2.1 taken from the project's website¹. ACT-R consists of three main components

- modules
- buffers
- pattern matcher

The perceptual-motor modules provide the interface to the environment. These are modules included in ACT-R that allow the interaction with the environment. For instance, a visual module can be responsible for collecting and processing information from a visual sensor, whereas a motor module could control the interfaces to the vehicle such as throttle or brake pedals. An example for the implementation of a visual module in the context of driving is presented in [57]. ACT-R contains two types of memory modules, the declarative and procedural memories. The declarative memory contains all the known facts and the procedural memory consists of, as the name suggests, procedures that represent the knowledge about how things are done in the world. In the case of driver modeling, how specific maneuver are executed could be stored as procedures. Most of the communication in ACT-R is done through buffers. Each

¹<http://act-r.psy.cmu.edu/about/>

2.3 Cognitive driver modeling

module contains one buffer, the content of which represents the current state of the buffer. The pattern matcher is the module responsible for modifying these states. It searches all the buffers for states that match the productions in the procedural memory, selects the best matching production and executes it, thereby modifying the contents of the buffers. In the context of driver modeling, the pattern matcher could be responsible for choosing between alternative maneuver types, or between different strategies for one type of maneuver.

A framework specifically intended for driver modeling that is based on a cognitive architecture is presented by Absil and Pauwelussen [58]. The framework, called Driver Modeling Library (DML), is a modification of the CHAOS framework, a computational model based on the pandemonium cognitive architecture [59]. The framework is intended as a driver model library, providing modules for decision making and driving behavior that can be extended to fit the specific needs of the model. Its purpose is to provide a model that can be integrated in traffic simulators. As is the case with most cognitive architectures, the framework is divided into specialized modules as depicted in Fig. 2.2. The heart of the framework is the *Cognition* module that does the mental

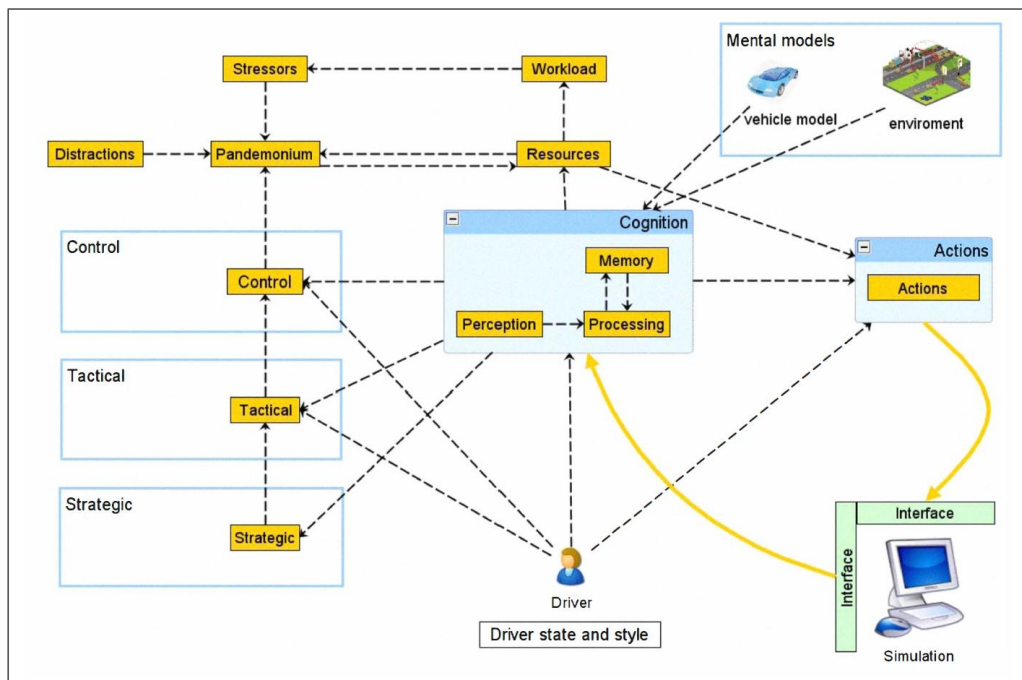

Figure 2.2: The DML framework, taken from [58]

2. DRIVING MANEUVER PREDICTION

processing, similarly to the pattern matcher in ACT-R. The processing results in actions that interact with the environment, influencing the state of the model. The parts that are specific to driver modeling are the *Driver* and the three hierarchical layers already mentioned in 1.3. Each of the layers contains buffers, called demons in the pandemonium architecture, that model aspects of the driver behavior found in that level. The driver's state is a temporary state that the driver finds himself in, which can change with time and influences the other components of the framework. An aggressive driver for instance could increase the weight of the demons on the tactical and control level that favor high accelerations. The authors provide an instantiation of the DML for the example of accepting a gap to turn left at an intersection as depicted in Fig. 2.3.

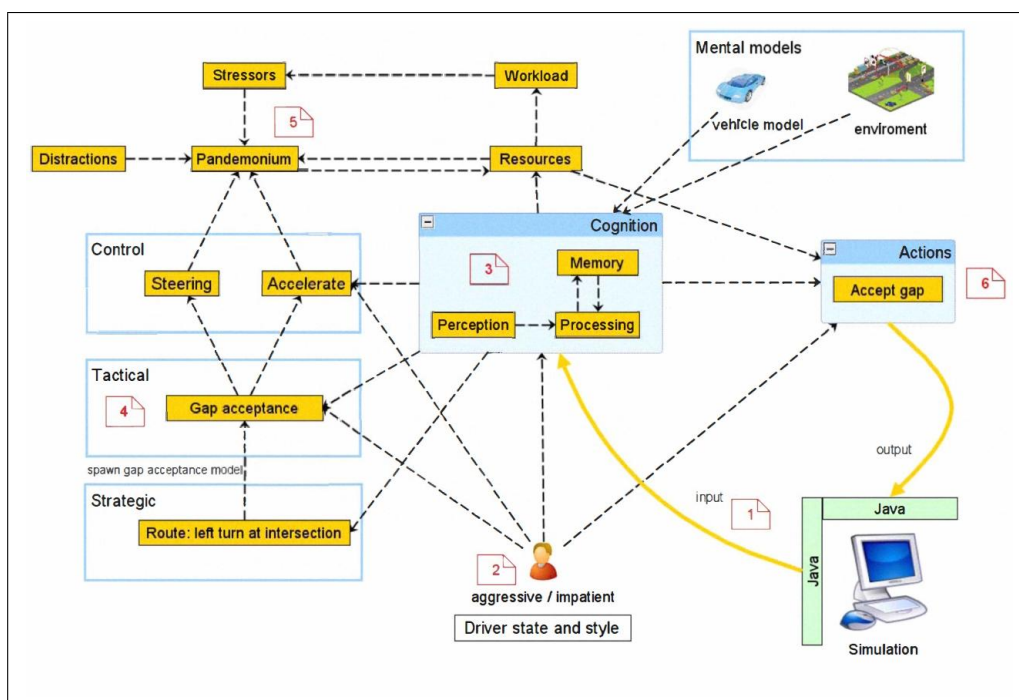

Figure 2.3: Gap acceptance model using the DML framework, taken from [58]

Modeling driving behavior using a cognitive architecture has several advantages. In the context of driver modeling as maneuver prediction models, cognitive models help to explain the motivation behind the selection of a particular maneuver as well as the cognitive aspects involved in that selection and its execution. For example, in order

to execute a lane change, the driver needs to acquire noisy visual information about the presence of vehicles on the current and target lanes, process that information and then execute the maneuver. These internal processes that form the driver's situation awareness, such as detecting vehicles, assessing their distances and velocities as well as choosing to perform a lane change motivated by the desire of reaching a goal faster, can be modeled in a cognitive architecture. An example of how to model situation awareness in a cognitive architecture and how it could be implemented in ACT-R is presented in [60].

The explicit modeling of the driver's mental state is an advantage of cognitive driver models. It can help disambiguate between otherwise indistinguishable states. In exactly the same car-following situation on a highway, for instance, choosing to overtake the leading vehicle or following it can depend only on the mental state, whether the driver is in a hurry or not. Considering these factors could improve the prediction accuracy for a maneuver and may lead to a correct prediction before any relevant behavior, such as setting the indicator signal, is observed. Since cognitive architectures provide an explicit representation of the mental state of the driver, they are also well suited to model mental states such as fatigue or distraction [39].

A third argument is that a cognitive architecture accounts for the limitations of human mental processing. Effects such as limited cognitive attention, humans cannot focus their attention on a variety of topics at the same time, or errors in perception or action execution can be modeled in a cognitive architecture and included in the prediction of driving maneuvers. For instance, Anderson et al. studied the effect of working memory, and its limitations, using two specific experiments and then fit the resulting data using a computational model of the experiments using ACT-R [61].

In spite of these advantages, only very few attempts have been made to model driving behavior in a cognitive architecture. Aasman's model [62], was the first to model driving behavior within the framework of a cognitive architecture (Soar), in this case that of a driver approaching an intersection. Salvucci developed a driver model based on ACT-R that predicts steering, lateral position and driver's gaze during lane keeping, curve negotiation, and lane changing maneuvers [63]. Song and colleagues presented a cognitive driver model that modeled car-following and overtaking behavior on highways [64]. It contains the *strategic*, *tactical* and *control* levels, as well as a *perception*

2. DRIVING MANEUVER PREDICTION

module providing information about distance and distance-rate to a leading vehicle. The previously mentioned hybrid driver model by Kiencke et al.[54] is another example of a driver model that includes the explicit modeling of human deficiencies.

There are two main arguments why cognitive driver models have not received more attention. Firstly, cognitive architectures are complex and require much input from the designer. For driver modeling, it is necessary to provide a large amount of domain knowledge about the driving maneuvers. Using the DML example from Fig. 2.3 for instance, it is necessary to model all the individual components of the three layers, such as the *Steering* component in the *control* level, the possible actions as well as the driver's state in a very detailed way. This is not easy, since driving is a very complex and interactive task. It is possible to build simplified models of a driving maneuver explicitly, but it is not feasible to consider all possible variants of a maneuver type and the interactions with the environment. It is difficult to describe even a simple maneuver in the first place, since much of it is done intuitively. Most of us are able to navigate a vehicle in a complex environment, but if we are asked to explain explicitly how we do it, we cannot give a detailed description of it. This is especially true on the control level, where most of the corrective actions are done subconsciously.

The second drawback, which is of essential importance for the model developed in this thesis, is the computational complexity of such a model. As is further discussed in section 3.1, a driver model that is to be included in a driver assistance system is only feasible if it uses resources sparingly and is capable of operating in real-time. As of now, these requirements cannot be met by a cognitive architecture. The computational requirements, both in computation time and memory usage, of a cognitive architecture designed to model aspects of human cognition, surpass the capabilities of most control units found in today's commercial vehicles. Given these limited resources, it is not possible to develop a cognitive driver model that can operate in real-time under these conditions. Given the resources required by cognitive models, most cognitive models have been developed to simulate a human driver in the context of traffic or driving simulations, where the necessary computational power is available.

2.4 Behaviorist driver modeling

Behaviorist driver models try to predict human behavior by observing how the driver interacts with the vehicle and his environment. In the case of maneuver prediction, the models try to infer the driver's intention by mapping his interaction with control elements available in the vehicle, such as steering wheel, accelerator or turn signal, to the maneuver being modeled. As mentioned above, internal states are generally not used in that representation. For instance the hypothetical knowledge of the driver being in a hurry is not explicitly used to infer a lane change to overtake a slower vehicle in front, even though this constitutes useful information.

External information besides the human/vehicle interaction are usually also taken into consideration. It is not possible to predict that the driver is approaching a leading vehicle without a sensor capable of detecting objects in front of the car. Likewise, a model which purpose it is to model how the driver stops at an intersection will have difficulties performing the task if no information about the distance to the next intersection is available. Additional information about the vehicle's state, such as its velocity, are also often used in the development of the models. Data that is vital for the explanation of the behavior needs to be accessible, otherwise no model can have sufficient information to build a reliable representation of the behavior.

Since behaviorist driver models build representations of that behavior by observing both the driver's actions and the environment, these representations are usually generated from data. Building a model from data is an inductive process, as opposed to a deductive model, where the model is built in advance using expert knowledge. Examples for deductive methods using knowledge about the general task of driving a vehicle and specific driving maneuvers were presented in the last section on cognitive driver models. As was mentioned in that section, it is difficult to model driving maneuvers in all their complexity from prior knowledge, making it appealing to generate models inductively. Many different techniques have been proposed that allow a model to be generated from data. An entire field of research within computer science, machine learning, is dedicated to the development of these techniques. Researchers have used machine learning for the purpose of modeling driving behavior from sample data. In the following sections, some of these machine learning methods and the respective driving maneuver prediction models are discussed.

2. DRIVING MANEUVER PREDICTION

2.4.1 Driver models based on neural networks

Neural networks are a powerful method for learning sample input - output relationships. A neural network consists of single computation elements, the neurons. These neurons are interconnected through edges of variable weight. The activation of each node is calculated as the activation of the connected input nodes multiplied with the weights of the connections between them. Several possible layouts of neural networks from the excellent tutorial on neural networks by Jain et al. [65] are shown in Fig. 2.4. Given a

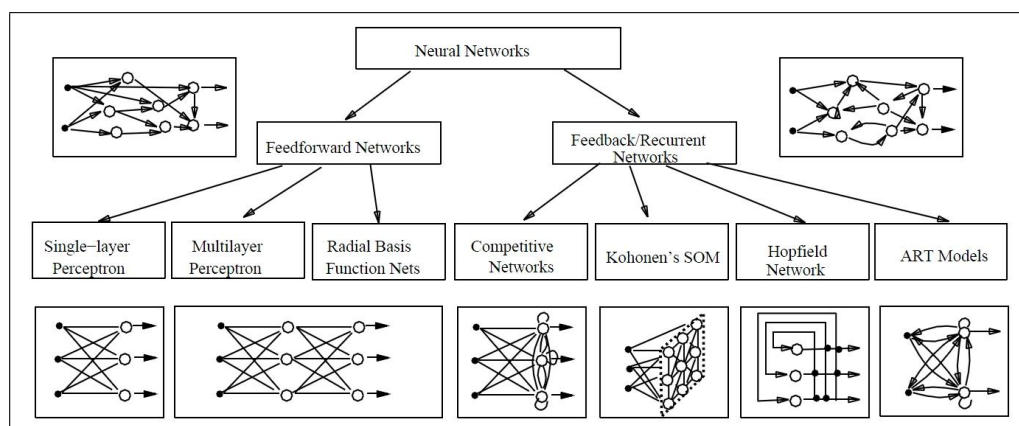

Figure 2.4: Taxonomy of neural networks, taken from [65]

number of data vectors of input and output data, the simplest forms of neural networks (single-layer or multi-layer Perceptrons) learn a mapping between these vectors by adjusting the weights of the connections in a learning phase. After the network has been trained, they can compute output values from input data not used in the training process. In the case of predicting driving maneuvers, the input of a neural network could be behavioral data such as steering angle or throttle position, and the output of the model a prediction value for that maneuver. An example for a neural network modeling the driver's steering behavior is presented in [66]. Kraiss and Küttelwesch [67] implemented a neural network that learns how to execute overtaking maneuvers from sample maneuvers. Dogan et al. [68] model lane changes on curved roads and compare lane changing to lane keeping scenarios with feed forward and recurrent neural networks. Lateral and longitudinal vehicle acceleration was predicted by a neural networks in [69]. Zadeh and colleagues [70] provide a good overview of automotive systems based

on neural networks up until 1997.

Even though neural networks are powerful learning mechanisms, their main disadvantage is that they are very difficult to analyze. The relevant information is stored in a distributed way in the weights of the connections. This information is not easily interpretable, which makes it difficult to use such a model in the context of driver assistance systems, where the traceability of the system is of utmost importance (see section 3.1). Another disadvantage is that most neural networks are not able to handle a temporal sequence of data points, but only compute the output for one data vector at a time. In the domain of driver modeling, especially for the prediction of driving maneuvers, the data usually consists of sequences of individual phases, and including this temporal information can be essential. The temporal aspect can be artificially added by constructing networks for each of the phases of a maneuver and arranging them in sequential order. The drawback is that specific knowledge about these individual phases is necessary. This restricts the characteristic of neural networks of being largely model-free, meaning that only very limited knowledge about the domain is necessary for the generation of such a network. Of course, neural networks are a vast field of research. Only the most simple form was discussed, other more complex types of networks, such as recurrent Hopfield networks, may be better suited for including temporal information in the prediction of driving maneuvers.

2.4.2 Driver models based on Bayesian networks

Bayesian networks (BN) are probabilistic models which provide the possibility to define a structure of causal dependencies between variables in a directed acyclic graph, where the directions of the links imply a causal relation from cause to effect. The dependencies are quantified by conditional probabilities regarding only direct causes of a variable. To give an example, a simple Bayesian network modeling an aching back taken from the tutorial by Ben-Gal [71] is depicted in Fig. 2.5. In the example, the variable *Back* represents a back injury, which can cause a backache (*Ache*). The injury can be caused by either practicing sports (*Sport*), or by a uncomfortable office chair (*Chair*). A fellow colleague (*Worker*) can also experience back ache due to having such a chair. Given the network and local probabilities, Bayesian inference can be used to extract knowledge from the network. The inference can be predictive, also called top-down reasoning, or diagnostic, also called bottom-up reasoning. In the case of predictive inference, it is

2. DRIVING MANEUVER PREDICTION

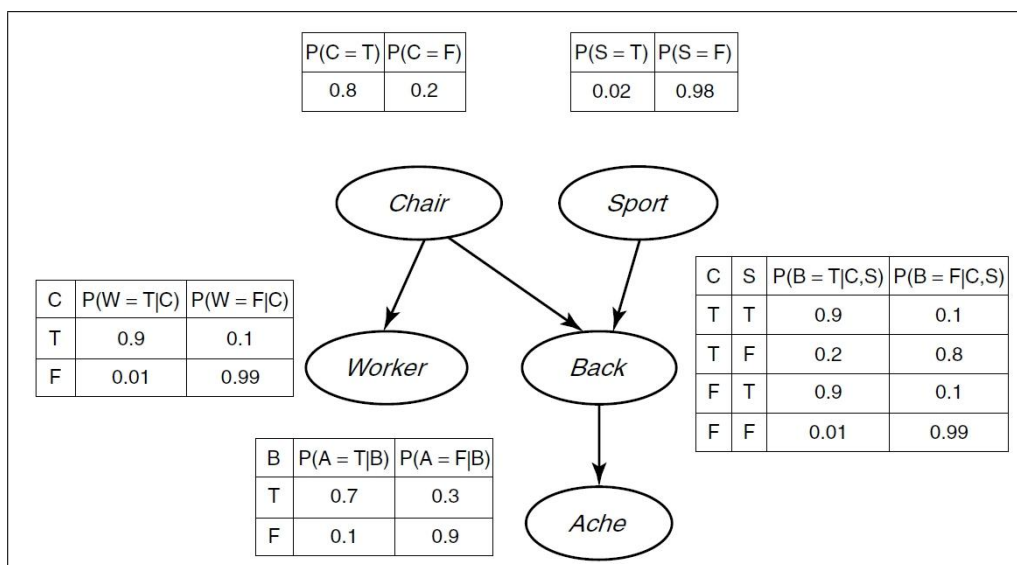

Figure 2.5: Example of a Bayesian network, taken from [71]

possible to calculate the probability of the person having backache from the purchase of a new office chair. One example for diagnostic reasoning would be the calculation of the probability that a new chair was installed in the office, given that the person suffers from backache. The network's topology and the joint probability distributions can be generated from data, a process known as the BN learning problem. Several methods have been suggested in the literature, mostly depending on whether the topology of the network is known and whether hidden nodes or only partially observable data is available.

In the case of driver modeling, diagnostic reasoning can be used to predict driving maneuvers. Given a BN for a sample maneuver type connected to relevant input variables, the values for these variables at any given time can be used to calculate the probability of the maneuver taking place. Kutzera provides an example for the reasoning process in his thesis[72]. The example is a turn maneuver, where new evidence for the variables *Direction Indicator*(a), *Steering Movement* (b) and *Driven Speed* (c) increase the probability that the driver is planning a turn maneuver. The probability values in Fig. 2.6 are fictitious values chosen to illustrate how the reasoning process works.

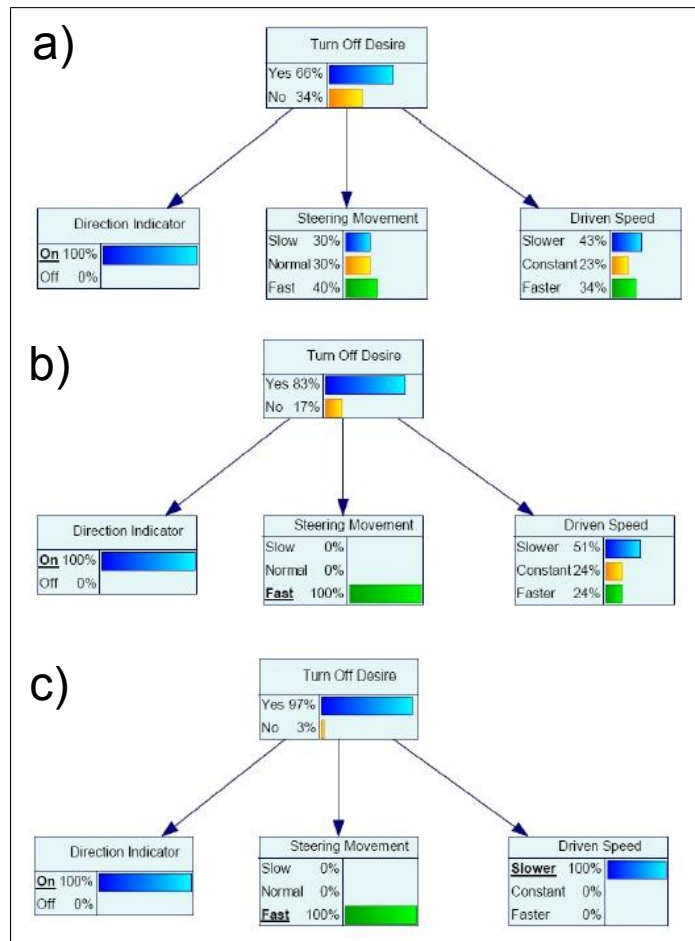

Figure 2.6: Example of a Bayesian network for turn maneuver prediction, taken from [72]

A variety of driver models have been implemented using Bayesian networks. Tezuka and colleagues [73] implemented a model that discriminates between lane keeping, lane change and emergency lane change using the steering angle as input information. Amata et al. [74] predicted stopping behavior at intersections based on environmental conditions (traffic signs, pedestrian crossing, leading vehicle) and a calculated driver type. In his thesis, Klanner [75] predicted the turn behavior at intersections using data from the vehicle (throttle and brake pedals, turn signal) and a navigation system.

Since Bayesian networks are probabilistic models, they are good at dealing with uncertainties. This is of advantage for driver modeling, where uncertainty plays a big

2. DRIVING MANEUVER PREDICTION

role. Not only are sensor measurements noisy, but there is always some uncertainty about the driving behavior. It is possible for the driver to react differently in similar situations, and being able to model this uncertainty is one of the main advantages of using Bayesian networks. Another advantage of Bayesian networks is that, being graphical models, they are relatively easy to implement given the necessary domain knowledge. The major advantage is the model's transparency. Since it is possible to do top-down and bottom-up reasoning, it is possible to inspect the state of the network and explain the reasoning process at any given time.

But there are also drawbacks when using Bayesian networks for driver modeling. One of the problems of Bayesian networks in general is the definition of the a-priori probabilities, which are often set to 0.5 to denote total ignorance about the distributions. However, as was stated above, learning methods have been suggested to estimate these probabilities. A drawback that simple Bayesian networks share with neural networks are the difficulty of including temporal information. A more complex form of Bayesian networks, dynamic Bayesian networks, can be used to model the change in a variable over time. However, this makes the construction and analysis of a network more complex. Yet another problem is caused by the discretization of the variables. For example, the variable *Steering Movement* in Fig. 2.6 is partitioned into three subsets. Finding the optimal borders between subsets is not straightforward. Which is for instance the border between a *Normal* and a *Fast* steering movement in the above example? To make matters worse, these boundaries are crisp. Given a partition of steering angle, it may be *Normal* at, say, 20° and *Fast* at 20.1° . These leaps can lead to erratic behavior in the probability calculations. It also does not characterize how humans reason about such variables, limiting the model's plausibility.

2.4.3 Driver models based on hidden Markov models

Hidden Markov models (HMM) are another type of probabilistic networks, a special case of BN. The purpose of a HMM is to estimate a Markov chain. A Markov chain consists of a finite number of states and transition between states. In each timestep of the chain, the next state is chosen randomly, where only the current state determines the probability distribution for the next state. This property of a memoryless transition probability is called Markov property.

HMM graphs consist of states, transitions between these states, observations and output probabilities. An example for a small HMM taken from Wikipedia¹ is shown in Fig. 2.7 where

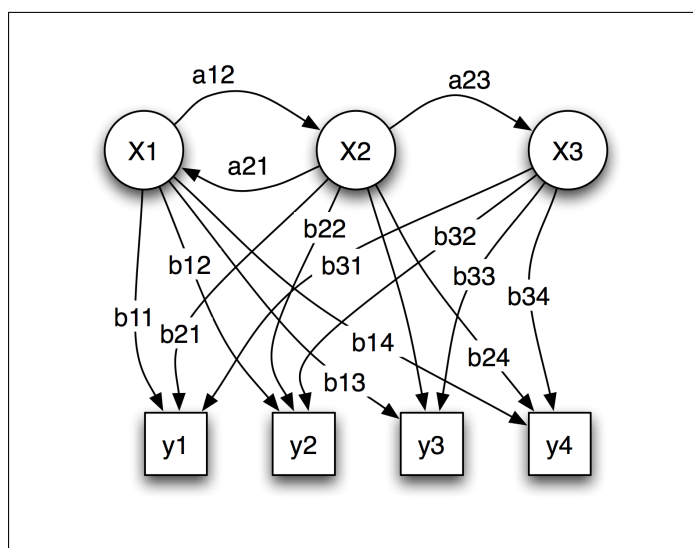

Figure 2.7: Example of a Hidden Markov Model

x_i = hidden states

y_i = possible observations

a_{ij} = state transition probabilities

b_{ij} = output probabilities

The Markov chain underlying the sequence of observations is not known and needs to be estimated using these observations. Because the states are not known, they are called hidden states. The output probabilities b_{ij} of a state x_i form a probability distribution over the possible observations. The HMM can be deduced from large amounts of data or from domain knowledge, if sufficient information exists about the origin of the Markov chain. One of the main uses of a HMM is to calculate the probability that a given sequence could have been generated by the model. This probability calculation can be used for driver modeling. If a HMM representing a driving maneuver and a sequence

¹http://en.wikipedia.org/wiki/Hidden_Markov_model

2. DRIVING MANEUVER PREDICTION

of input data exist, the probability of that sequence being caused by the HMM, and as a result the probability for a maneuver, can be computed.

An example for a driver model using HMMs was proposed by Kuge et al. [27]. The model consisted of three HMMs, one for each of the maneuvers emergency lane change, ordinary lane change and lane keeping. Fig. 2.8 shows the model consisting of one node for lane keeping recognition (lkn), followed by sequences with n nodes for ordinary lane change (lcn_1 to lcn_n) and m nodes for emergency lane change (lce_1 to lce_m) recognition connected to the node lkn . Each of the nodes is a sub-HMM, a possible layout of such

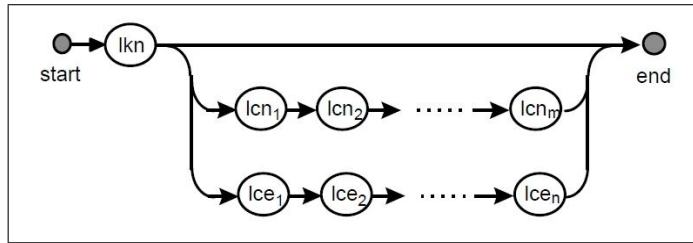

Figure 2.8: HMM for lane change recognition, taken from [27]

a sub-HMM is depicted in Fig. 2.9. The states S_i in a sub-HMM represent individual

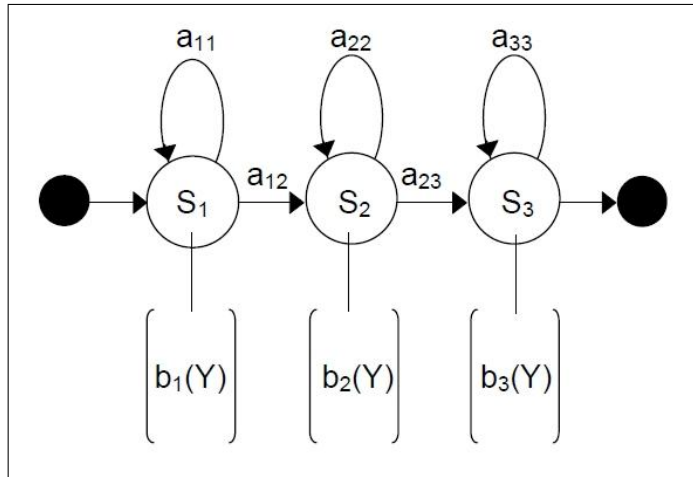

Figure 2.9: Sub-HMM for lane change recognition, taken from [27]

stages of a maneuver. The number of states depends on the complexity of a maneuver as measured by the number of distinguishable stages. For their experiments, the HMM

consisted of three sub-HMMs for lane change and emergency lane change recognition, and three states for each sub-HMM. The observations were values for steering angle, steering force and steering angle velocity. Different permutations of those variables were also studied. The parameters were trained using data from lane changes and normal driving obtained in a driving simulation experiment. Given a sequence of observations of the input variables, the HMM with the highest probability of producing it was used to classify the sequence and hence recognize the maneuver.

Other driver models that predict lane changes based on HMM haven been proposed ([29],[76],[77]). Oliver and Pentland [76] developed a new type of HMM, Coupled Hidden Markov Models, capable of modeling interacting processes often found in real-time environments such as driving. The prediction of stopping maneuvers at intersections using HMM was studied in [78].

Since the strength of a HMM is sequential pattern recognition, they are suited for the prediction of driving maneuvers, given that these are sequential in nature. However, as is the case with Bayesian networks, the number of states and values for the parameters of the model need to be computed, which may require a large amount of data. The number of hidden states may be chosen through knowledge about a driving maneuver, but that can be a challenging task. For example, in the HMM from Fig. 2.9, which is the reason for choosing three states for each sub-HMM over any other number of states? This is the same problem of having to model a maneuver in a very detailed way already discussed in section 2.3 in the context of cognitive driver models.

2.4.4 Driver models based on fuzzy logic

Fuzzy logic is a form of logic used for approximate, rather than exact, reasoning. The basic principles of fuzzy logic are covered in section 3.2. The theory provides a plausible representation for human reasoning. Since driving a vehicle is largely a reasoning process, it is intuitive to use fuzzy logic to model driving behavior, especially in the context of driving maneuvers.

Schmitt and Färber [24] implemented a prediction system based on fuzzy logic to separate emergency braking from merely strong braking behavior. Fuzzy rules were designed using three variables, the impulse with which the throttle pedal is released, the radius of the throttle curve at the begin of that release and the time difference between release of the throttle and begin of braking. The goal of the authors is to use

2. DRIVING MANEUVER PREDICTION

the prediction information to improve an emergency braking system, which is also the goal of the autonomous braking system developed in chapter 5. An example of a related method that implements a control strategy for an electronic hydraulic brake using fuzzy logic and braking intention recognition is presented in [79]. Färber's research group used other input signals to predict overtaking, lane keeping and turning maneuvers [80]. Relevant input signals were studied and selected according to their ability to produce distinctions between the maneuvers. A total number of six variables was selected, fuzzy variables defined for each of them and 110 rules generated to predict the maneuvers. Ohashi et al. also predict left and right turns using fuzzy logic and case-based learning [81]. Khodayari and colleagues implemented a car-following model based on fuzzy logic aimed at predicting the driver's car-following behavior [82].

The main advantage of fuzzy logic is its similarity to human reasoning. It is possible to construct fuzzy models that model the domain in a realistic and interpretable way. The quality of the model is increased, the better the fuzzy variables and fuzzy rules capture the way humans reason about and behave during, in this case, a driving maneuver. This, however, is one of the biggest difficulties when using the theory. As with the methods based on Bayesian networks or Hidden Markov Models, a significant amount of expert knowledge is usually needed to establish the fuzzy variables and rules describing the domain. In most of the above methods, and in many publications concerning fuzzy logic in general, the fuzzy variables and rules are defined by experts, who use their domain knowledge to estimate the shapes of the fuzzy sets and the rules included in the rulebase. As will be shown in the next chapter, a few methods have been proposed that generate fuzzy variables or rules from data obtained through the observation of human behavior. However, none of them takes individual differences into account, which can potentially be significant and thus limit the validity of the generated model. In the next chapter, a method that generates driver-dependent fuzzy variables and rules from driving data is described. The method provides a highly specific fuzzy model of driving behavior for the respective driver with very limited necessity for expert, and thus subjective, domain knowledge.

3

A fuzzy logic based driver model

3.1 Introduction

In this chapter the driver model developed in this thesis is presented. The central goal of the model is to build a representation of driving behavior from sample driving maneuvers and to use it to predict future maneuvers of the same kind. That prediction in turn is used to adapt an exemplar driver assistance system to the individual driving behavior. As such, the model has to meet a number of criteria derived from both domains driver assistance systems and behavior prediction. These requirements provide the arguments for choosing fuzzy logic instead of other well established learning techniques from computational intelligence.

In order to be feasible for the task of adapting a driver assistance system, a driver model has to meet at least the following requirements:

1. **Real-time capability.** The adaptation of a driver assistance system has to be done in real-time, since these operate continuously based on real-time input from vehicle and sensor data.
2. **Limited use of resources.** The computation power of control units found in modern vehicles is, even if it has increased in the past years, limited. A driver model needs to use memory and computation time sparingly if the aim is to implement it on vehicle hardware.
3. **Traceability.** The representation of driving behavior has to be analyzable. This means that it must be possible to inspect the model and infer its behavior from

3. A FUZZY LOGIC BASED DRIVER MODEL

that inspection.

The first two requirements constitute the main reason why no cognitive aspects were taken into consideration for the development of the driver model. As was argued in section 2.3, current models representing human cognition require a substantial amount of computation time and memory resources. As will be demonstrated in section 4.2.4, the fuzzy driver model presented in this chapter is capable of running in real-time and uses resources sparingly. The reasoning behind the third requirement is that driver assistance systems generally need to fulfill a number of safety requirements before they are allowed to be included in production vehicles. This means that any software modifying the behavior of such a system also needs to meet all or most of these requirements, including the traceability of the software's behavior. This rules out subsymbolic learning techniques such as neural networks. Even though they are powerful methods for learning from sample data, the resulting model's behavior is difficult, if not impossible, to inspect analytically. As a consequence, it is not possible to completely rule out faulty behavior by the system without testing each possible combination of input data, which for the complex domain of driver assistance systems is prohibitively high. As will be pointed out in section 4.2.4, the method developed in this thesis delivers a model that is easily understandable and verifiable.

Other, less mandatory, criteria are based on the task of representing and predicting driving behavior on the tactical level:

1. The closer the driver model's representation of a maneuver is to our own notion of how maneuvers are executed, the more faithful and easily understandable it can become.
2. The better the model's representation of the relevant behavioral variables resembles our own perception of them, the more realistic the model can become.
3. The more the model adapts to the individual driver, the better the prediction of his behavior can become.

To illustrate the first point, it is helpful to provide an example of how a human being could reason about a maneuver, in this case stopping behind another vehicle at a traffic light:

”I see the vehicle in front decelerating when the traffic light turns red. I continue driving with the same speed until I am relatively close to it, whereupon I release the throttle. I wait until I get close to it, after which I first apply a strong and then a weak force on the brake until I come to a standstill close behind it”.

The above example suggests that the way human beings think about driving on the tactical level is essentially sequential and rule-based. As a consequence, it lends itself to represent the driver’s behavior for a given maneuver as a sequence of rules, as was already pointed out by Michon[48] as early as 1985. This is more intuitive than, say, modeling driving maneuvers as a Bayesian network, where the reasoning is based on abstract probabilities not directly perceived by the driver, such as the probability of a lane change being 66% if the turn signal is activated (see section 2.6).

If behavior is modeled as a sequence of rules, it is necessary to define how these rules are constructed and what they consist of. As was stated earlier, the model disregards any internal human aspects, be it cognitive, sensory or motor, involved in carrying out a maneuver. This leaves only those variables that are observable by vehicle sensors or can be computed based on them. In the case of the example maneuver above, one such variable could be the distance to the preceding vehicle as measured by an on-board radar. These variables need to be discretized if rules are to be built from them. For instance, if the stopping behavior is to be modeled by a sequence of rules involving the distance to a vehicle, this distance has to be partitioned into sets that represent a concept, as for instance ‘low’, ‘medium’ and ‘high’ distance.

Modeling driving behavior as a sequence of rules leads to two central questions that need to be answered. The first one is how the variables are partitioned. In the above example, what exactly is a ‘low’ distance? This could be solved by defining that a ‘low’ distance is everything between 0 and 10 meters, a ‘medium’ distance between 10 and 20 meters and so on. This approach is very simple, yet it has two main drawbacks. For one thing it is assumed that the notion of a ‘low’ distance is the same across all humans. As a consequence, if a rule involving a ‘low’ distance is used to model driving behavior, it will not be an equally good representation for all drivers, since each has a different notion of what a ‘low’ distance is. It is also not compatible with human reasoning to split the variables into crisp sets. Why should a ‘low’ distance end at 10

3. A FUZZY LOGIC BASED DRIVER MODEL

meters as opposed to, say, 11 meters? Humans usually do not use crisp categories when reasoning about continuous dimensions, which is one of the main reasons that lead to the development of fuzzy logic. For these reasons, in this thesis the driver model uses fuzzy logic to describe the driver's behavior. In section 3.2, the foundations of fuzzy logic are explained, followed by a method in section 3.3 that derives driver adaptive fuzzy variables for maneuver prediction from driving data.

The second question is related to the generation of the rulebase. There are two possibilities how to construct the rules and rule sequences, either through design by an expert or data-driven given sample maneuvers. It was suggested that different drivers have different strategies, which in turn lead to different rules and rule sequences. It is very difficult to model all possible maneuver behaviors for all possible drivers in advance. Even if it were possible, many of the designed rules will not be valid representations for the individual driver, reducing the model's performance. The alternative approach is to generate the rulebase using sample maneuvers detected while driving. The method developed in this thesis follows the latter approach. The details of how rules are generated for each individual driver is explained in section 3.4, followed by the generation of a state machine representing the sequential nature of a driving maneuver in section 3.5. Ultimately, this state machine is used to predict the driving maneuvers.

3.2 Fuzzy Logic

As was argued in the previous section with the example of distance, modeling a continuous variable as a collection of crisp sets can be disadvantageous, especially when dealing with human reasoning, where uncertainty plays a big role in the reasoning process. No human being would state that a distance to an object of 10 meters is certain to be 'low', whereas a distance of 10.1 meters is certain to be 'medium'. We would rather agree that there is a region of uncertainty between the concepts 'low' and 'medium' distance. How this vagueness can be expressed in mathematical terms and hence used in modeling aspects of reality where vagueness plays a role is the central goal of fuzzy logic.

Fuzzy logic is a theory that was founded by Lotfi Zadeh in 1965 [83]. In that paper he introduces the concept of a fuzzy set, where the members of that set belong to it to a certain degree, as opposed to either inclusion or exclusion found in classical logic. It is

possible in fuzzy logic to state that a proposition, such as '10 meters is a low distance', is true only to a degree between 0 and 1. Fuzzy sets are capable of expressing gradual transitions from membership to nonmembership and viceversa. A collection of fuzzy sets that combined cover the entire domain of a variable is called a fuzzy variable. An example of how such a variable can look like is depicted in Fig. 3.1.

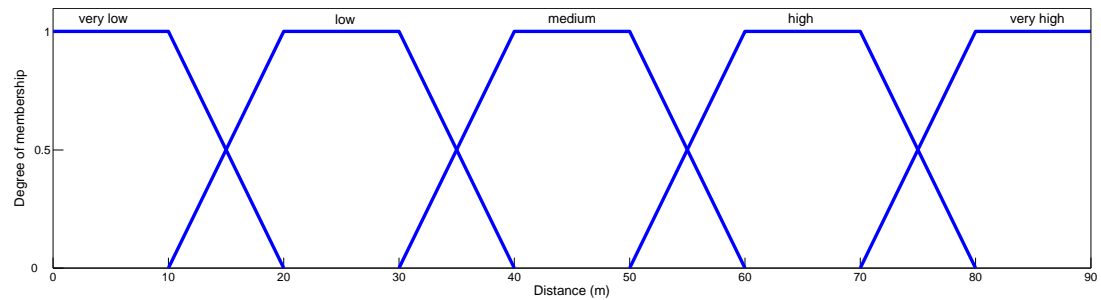

Figure 3.1: The fuzzy variable *Distance*

This variable consists of 5 overlapping trapezoidal fuzzy sets. The membership function for each fuzzy set is a trapezoidal function $\mu_V^s(x)$, V denoting the fuzzy variable and s the fuzzy set this membership function defines. In the remainder of this thesis, fuzzy variables are always written with a capital first letter, fuzzy sets always kept in lowercase and both in italic. In the literature the notions of membership functions and fuzzy set are used interchangeably, since they describe the same concept. In trapezoid membership functions there is always one region with membership $\mu_V^s(x) = 1$, one or two with $0 < \mu_V^s(x) < 1$ and again one or two regions with $\mu_V^s(x) = 0$. Instead of trapezoids, other functions such as triangular or bell shaped have been used. The sizes of the fuzzy regions that determine the degree of fuzziness can also vary, increasing or reducing the fuzziness of the model and hence the distance to classical two-valued logic. Some criteria for how fuzzy variables should be partitioned in general and in the special domain of driver modeling are presented in section 3.3.

Once the fuzzy variables have been defined, these can be used to reason about the problem. There are different ways how fuzzy models can be constructed, a short overview is given by Pedrycz and Gomide [84] in chapter 10.3. In the context of this thesis, the model uses a rule-based representation. In a rule-based fuzzy model, the information is represented as a number of IF-THEN statements that connect fuzzy

3. A FUZZY LOGIC BASED DRIVER MODEL

sets from the antecedent of the statement, here variables such as *Distance* or *Speed*, to one fuzzy set from the conclusion, which in this case is a singleton representing a driving maneuver. These rules describe the possible states while performing a driving maneuver. For instance, one rule consisting of the variables *Distance to a preceding vehicle* (D) and *Brake Pressure* (B) in the antecedent and the fuzzy variable *Maneuver* (M) in the consequent that expresses stopping behavior could be

IF D is *very low* **AND** B is *high*
THEN M is *stopping*

The truth value of the antecedents (the IF-expressions) at any given time is computed by fuzzifying the input variables. This is done by computing the degrees of membership for the corresponding set in each input variable and calculating the intersection of these degrees, for instance by employing the $\min()$ operator. This results in a single value for the truth value of the antecedent of the rule. In the special case of classification, this is also the truth value for the consequent (the THEN-expressions) of the rule, because the fuzzy sets for the output variable are singletons. Figure 3.2 shows the fuzzification and intersection steps for the rule shown above.

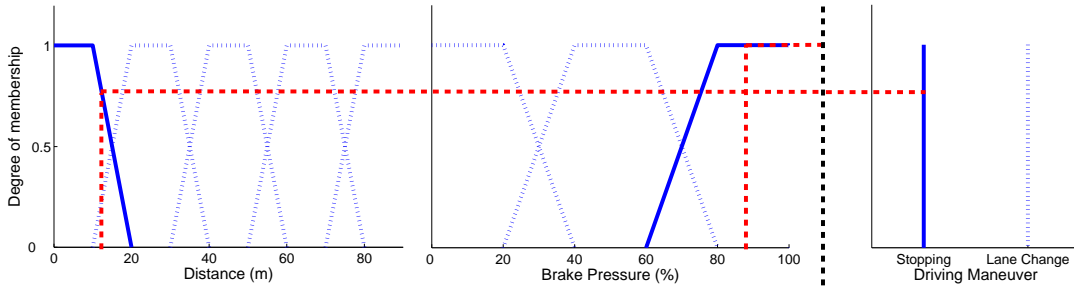

Figure 3.2: Example rule for the maneuver 'Stopping behind a vehicle'

The values for the input sets are

$$\begin{aligned}\mu_D^{very\ low}(x) &= \mu_D^{very\ low}(12.5) = 0.75 \\ \mu_B^{high}(x) &= \mu_B^{high}(87) = 1.0\end{aligned}$$

Calculating the intersection $\min(0.75, 1.0) = 0.75$ leads to a truth value for the rule's consequent of $\mu_M^{stopping}(0.75) = 0.75$. This computation is done for all the rules with

the maneuver *stopping* as the rule's consequent. In the special case of having output variables consisting of only singletons, the truth value for the maneuver is computed by taking the union of all these values. In accordance with employing $\min()$ operator for the intersection, the union is typically calculated using the $\max()$ operator. Thus, the truth value of a fuzzy set in an output variable, in this case a maneuver type, is the highest truth value of any rule antecedent with that class as a consequent.

There is of course much more to fuzzy logic than what has been covered in this section. Only those aspects of the theory that are necessary for understanding the model developed in this thesis have been introduced. Fuzzy logic is a very active branch of computational intelligence with a number of conferences and a large amount of publications constantly developing the theory further. For a complete coverage of the basics of fuzzy logic, the excellent book by Klir and Bo [85] can be recommended. Newer developments, such as type-2 fuzzy logic [86], where even the membership values are uncertain, fuzzy neural networks [87] or evolving fuzzy systems [88], have increased the power of fuzzy logic and are also recommended to the reader interested in the theory of fuzzy logic.

3.3 Driver-dependent fuzzy variables

We have seen in the previous section that the foundation of fuzzy logic is the concept of fuzzy sets and fuzzy variables. The way the fuzzy sets are defined influences the performance of the fuzzy model. If a partition of a fuzzy variable into fuzzy sets does not represent the concept properly, the fuzzy model is bound to exhibit poor performance at explaining the underlying physical process in a realistic way. For the domain of modeling driving behavior, this means that a fuzzy variable, for instance *Speed*, needs to have a connection to how that variable is perceived by a human being in the context of driving a vehicle. Furthermore, each individual driver has a different notion of what constitutes a, say, *medium Speed*. This driver-dependency needs to be taken into account.

Some attempts have been made to assess how relevant variables are perceived in the context of driving a vehicle. In a study conducted on a highway in California, Ayres and colleagues [89] studied the behavior of drivers under three varying conditions, free flow, rush hour, and heavy traffic. They analyzed how drivers regulated two variables,

3. A FUZZY LOGIC BASED DRIVER MODEL

the vehicle's velocity and the time headway to the preceding vehicle and extracted the preferred values for those variables under the aforementioned conditions. Another experiment was conducted by Wang and colleagues [90], studying time headway and the switch time between accelerator release and brake activation. These methods, however, provide only limited information for the partitioning of a fuzzy variable, since they merely compute single values (such as the preferred velocity) that are difficult to convert into a collection of fuzzy sets. They may serve as guidance for the specification of, say, a *medium Velocity*, but they offer only limited information about how the driver perceives a *high Velocity*.

A method that does partition fuzzy variables into fuzzy sets based on human perception of those variables was proposed by Wu and colleagues [91]. They studied car-following and lane-changing behavior on highways, modeling these maneuvers with the three fuzzy variables *Relative Speed (DV)*, *Distance Divergence (DSSD)* and *Acceleration Response*, where *DSSD* represents the ratio of vehicle separation, *DS*, to the drivers desired following distance. In order to generate the rules describing the behavior, the fuzzy variables had to be generated. To that end, the authors conducted an experiment with six subjects for a duration of two hours on a highway. During the experiment, the drivers had to follow a vehicle at a desired distance. The target vehicle performed a number of acceleration/braking maneuvers in order to study the driver's response to those changes. After some time, the driver was asked to overtake the target vehicle and approach a slower moving vehicle until the desired distance was reached. At the beginning and at the end of each test drive, the study supervisor asked the driver to give spontaneous verbal response to the current car-following situation using the verbal terms for the relevant variables, for instance that the *Relative Speed* was *about zero*. The exact values for the variables were simultaneously recorded by a range sensor to link the fuzzy sets to the actual values.

Fig. 3.3 shows a histogram of all the values that were classified as a *Relative Speed* of *about zero* by any of the drivers during the experiment. This histogram was then used to construct the triangular fuzzy set in Fig. 3.4. In this case, there was high agreement between the individual drivers. However, when asked about the vehicle *Separation (DS)*, the responses varied substantially among drivers. The lowest value for a *satisfied Separation*, as measured by the time headway, was reported at 0.61 seconds, whereas the highest value lay at 1.92 seconds, approximately three times as high. Hence,

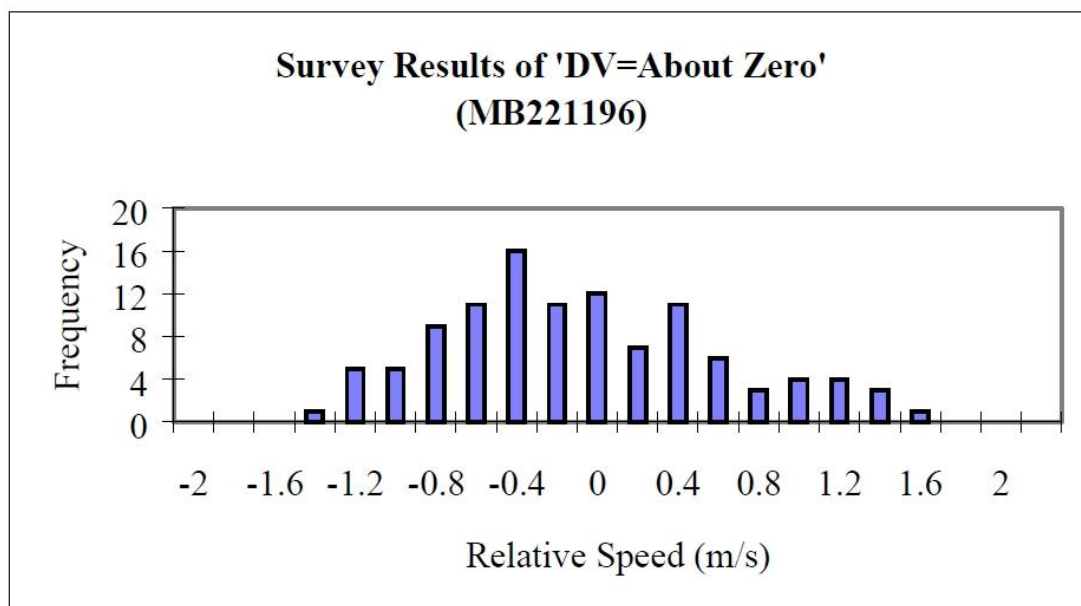

Figure 3.3: Histogram for Relative Speed, taken from [91]

it is difficult to generate a single fuzzy set from that data that accommodates each individual's concept of the fuzzy set, since these are fundamentally different. This is another example illustrating the need for driver-dependent driver modeling. The authors solved the problem by using the fuzzy variable $DSSD$ instead of DS , which showed higher similarities across subjects. This raises the question of determining the driver's desired following distance, which is also a driver-dependent value.

Even though the above method does provide a partitioning of fuzzy variables into fuzzy sets that is consistent with human mental representation, it is not applicable in the context of driver-dependent modeling of human behavior based only on driving behavior, which is the goal of this thesis. The reason is the driver's verbalization needed for the generation of the histograms. An observer is necessary to carry out these verbalization experiments, which is clearly not possible in this context. Hence, a technique needs to be devised that generates the partitioning from sample data alone. How a fuzzy variable is generated driver-dependently from driving data is the topic of this section. It involves the following three steps:

3. A FUZZY LOGIC BASED DRIVER MODEL

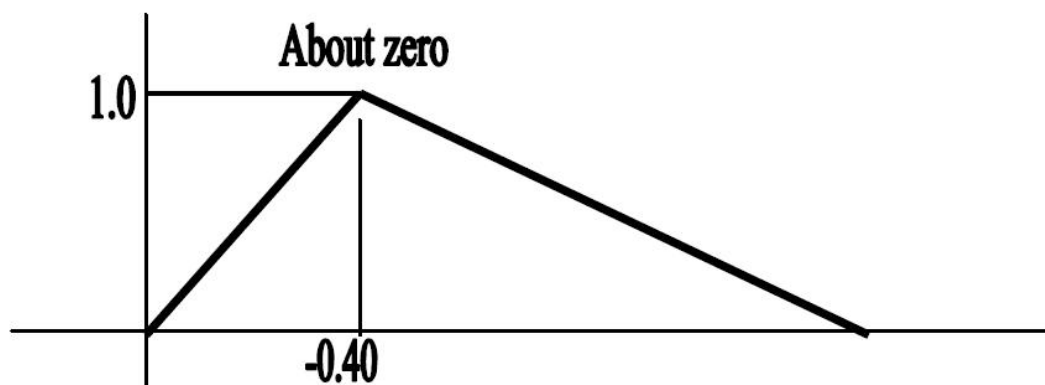

Figure 3.4: Fuzzy set for *about zero*, taken from [91]

1. Generating a histogram for the variable from sample driving data.
2. Approximating the histogram through a Gaussian-Mixture-Model (GMM).
3. Converting the GMM into the fuzzy sets of the fuzzy variable.

These steps are explained in more detail in the remainder of this section. An example variable that is easily understandable and often used in driver modeling is used to demonstrate the process. This variable is the velocity of a vehicle in an urban environment. The data stems from one subject in a field study carried out as part of the work presented in this thesis. The field study is described in detail in section 4.1.

3.3.1 Histogram generation from sample data

The data for the histogram was collected by recording the speed information from the vehicle's CAN-bus for approximately half an hour while driving in an urban setting with speed limits of 30 and 50 km/h. The range for the histogram is between 5 km/h (to exclude the periods of standstill) and 70 km/h (the speed limit on German urban roads is usually 50 km/h) in steps of 0.5 km/h. The histogram in Fig. 3.5 is typical for a journey with longer periods of unhindered driving and reasonably good weather conditions. There are two peaks in the histogram, one small at around 30 km/h and a dominant one between 41 and 54 km/h. This is to be expected, since the route the driver took during the field study was a mix of streets with speed limits of 30 and 50

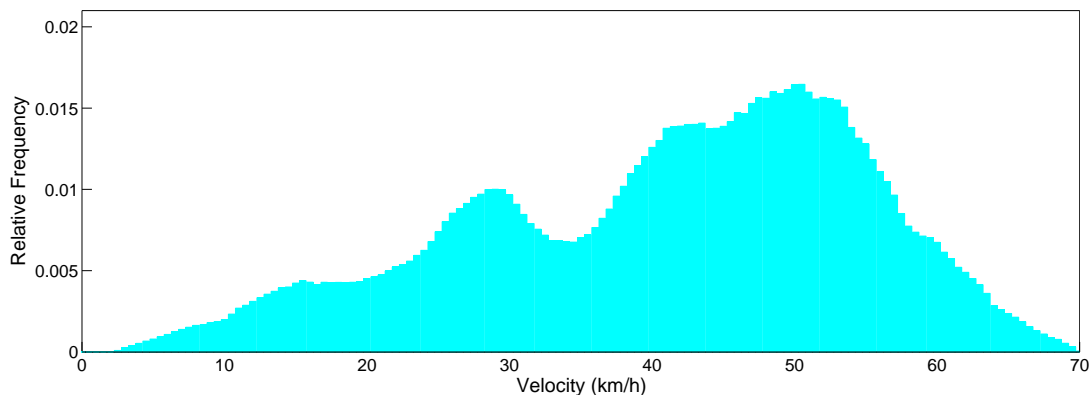

Figure 3.5: Histogram of velocity in an urban environment

km/h, with a larger amount of roads in the latter category. This histogram constitutes a speed profile for the driver. In this case the preferred speed is somewhere between 41 and 54 km, this region being the one with the highest relative frequency of data samples. Clearly, a fuzzy set that covers this region has an intuitive semantic meaning. This set describes how the individual driver perceives the vehicle’s velocity and (maybe subconsciously) tries to stay in a comfortable speed zone as suggested by the relative frequencies of the histogram. Given an appropriate number of sets, it is possible to generate a fuzzy variable that describes the driver’s behavior as represented by the histogram. How the fuzzy sets are generated from such a histogram is presented later in this section.

Since the shape of the histogram is essential, an important question to be answered is how long it takes for such a histogram to reach a stable state. A stable state is a histogram that does not change substantially when new data is observed. This can be studied by quantifying the effect new data has on the shape of the histogram. If new data does not change the histogram’s distribution substantially, it can be argued that the histogram has reached a stable state. In order to assess the degree to which a histogram changes over time, it is necessary to define a similarity measure between histograms. A variety of distance measures have been suggested in the literature, ranging from simple measures such as the bin-wise difference between two histograms to more sophisticated approaches such as the Bhattacharyya metric [92] or the earth mover’s distance [93]. The latter was used in this thesis, because it best captures the

3. A FUZZY LOGIC BASED DRIVER MODEL

general differences in shape between the distributions as opposed to measures that only account for local differences between neighboring bins.

The earth mover's distance is best depicted as the amount of work necessary to convert one pile of earth, hence the name, into another pile. This measure takes into account the amount of earth to be moved, as well as the distance the earth needs to be carried. In the context of histograms, the distance is how much relative frequency has to be moved between bins and how far these bins are apart from each other. Given this distance measure, the question is how much the histogram changes over time. To answer this question for the above example, histograms were constructed at different times during the trip and the distances between neighboring histograms calculated. Each histogram in the sequence included all previous data points up to that time. The results are presented in Fig. 3.6.

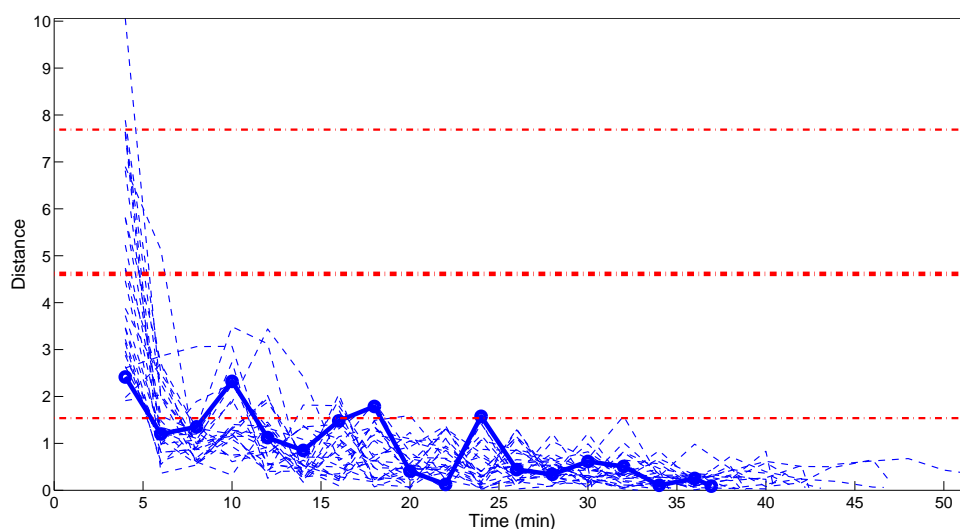

Figure 3.6: Histogram distances for velocity in an urban environment

The thick curve represents the distance between histograms two minutes apart from each other for the driver of above histogram. The thinner curves depict the same curves for the remaining drivers in the field study. To put the distance values into perspective, the horizontal lines show the mean (thick line) and standard deviations (thin lines) of interindividual histogram distances computed using the final histograms at the end of the trip. Each of the blue lines converges to a value close to 0, which is not surprising

given that the histograms incorporate all previous data. It is interesting to note that all the histograms start with big distances, which are quickly reduced in the first minutes. After approximately 8 minutes, almost all drivers had reached a high similarity between neighboring histograms. For some the distances increase again afterwards, but at around 16 minutes of driving all histograms reached a sufficiently stable state. At that time all subsequent distances between histograms have a substantially lower distance than at the beginning of the trip as well as the distances between individuals.

This experiment was carried out with varying amounts of time between histograms and also taking only certain windows of previous data as opposed to the total amount of data, the results varying only in details. This experiment was also carried out with other signals, for instance brake pressure or throttle position, yielding similar time frames. In general it can be stated that it takes approximately 15 to 20 minutes of driving in inner-city areas for a histogram of continually arriving signal values to stabilize. This is not true, of course, for those signals that only deliver data when certain environmental conditions are met, such as the distance to a leading vehicle. If no such vehicle is present, no data is available to generate the histogram from. For those cases it cannot be determined in advance how long the driver needs to conduct his vehicle before the variable reaches a stable state. For the signals concerning a leading vehicle it turns out that approximately six minutes of data were enough to reach a stable state, which, given the traffic conditions found in the study, also amounted to roughly 15 minutes of driving.

3.3.2 Histogram approximation through a Gaussian-Mixture-Model

As was argued in section 3.3, the histogram of a variable can be used to generate driver-dependent fuzzy sets. Any feasible method needs to take the shape of the histogram into account. The point can be illustrated by using a percentile-based approach, in which the histogram is converted into fuzzy sets by setting the parameters of the trapezoids according to certain percentile values. For the example in Fig. 3.5, a plausible fuzzy set describing *high Velocity* could be defined by a trapezoid based on the 40th, 50th, 80th and 90th percentiles, as depicted on the left side of Fig. 3.7. The same percentiles do not yield a plausible fuzzy set when applied to a different histogram, as can be seen on the right side of Fig. 3.7. Hence, different percentiles are needed for different histograms. How to set the appropriate percentiles for the specific histogram is a challenging task,

3. A FUZZY LOGIC BASED DRIVER MODEL

since characteristics of the distribution, for instance skewness and kurtosis, need to be considered.

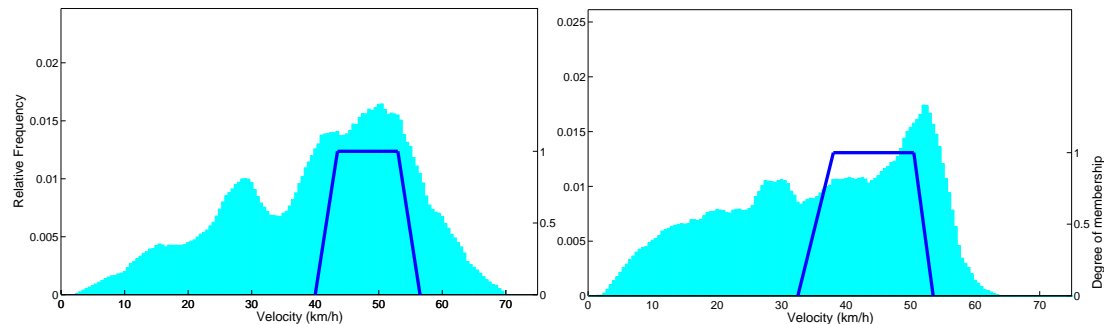

Figure 3.7: Fuzzy sets for *medium Velocity* of two drivers based on percentiles

A method is developed in this thesis using a Gaussian-Mixture-Model (GMM) to transform the histogram into fuzzy sets taking its shape into consideration. A GMM is a collection of Gaussian functions that combined approximate any given function to an arbitrary degree, depending on the number of Gaussian functions involved. To give a detailed explanation of how the GMM-algorithm works is beyond the scope of this thesis. For the interested reader, a good introduction to the basic principles can be found in [94]. The elegance of this method is that, given the right number of Gaussians, each covers a different area of the function to be approximated, taking the local minima and maxima of the distribution into account. In the context of this work, the function to be approximated by the GMM is the histogram of a signal. Given the adequate number of Gaussians, it is possible to then convert the Gaussians into fuzzy sets and hence the histogram into a fuzzy variable. Preliminary results obtained by applying the method on data from a field study [95] already showed that using fuzzy variables generated by this approach do differ significantly between drivers, depending on their individual behavior [96].

It is necessary to consider how many Gaussian functions should be used to approximate the histogram. This number depends a variety of aspects:

1. **Signal creating the histogram.** Each signal generates a histogram with distinctive shape and meaning that has to be treated individually.
2. **Context of the variable.** Each variable also potentially generates different histograms depending on the context (e.g. street type, see section 2.1) in which it was recorded.
3. **Application area.** The number of signal depends on how granular the fuzzy sets need to be for a given application.
4. **Constraints on fuzzy variables.** There are a number of constraints on the shape and number of fuzzy sets in any fuzzy variables for it to be semantically meaningful.

To illustrate the first point, a histogram for velocity is very different in shape from that for yaw rate. Fig. 3.8 displays both histograms for one driver of the field study. Since the histogram for yaw rate is almost symmetrical, it is reasonable to partition the fuzzy variable into an odd number of fuzzy sets, in practice either three or five. The fuzzy variable *Velocity* on the other hand does not have this constraint, depending on the purpose any number of sets between three and six can be reasonable. The context of the

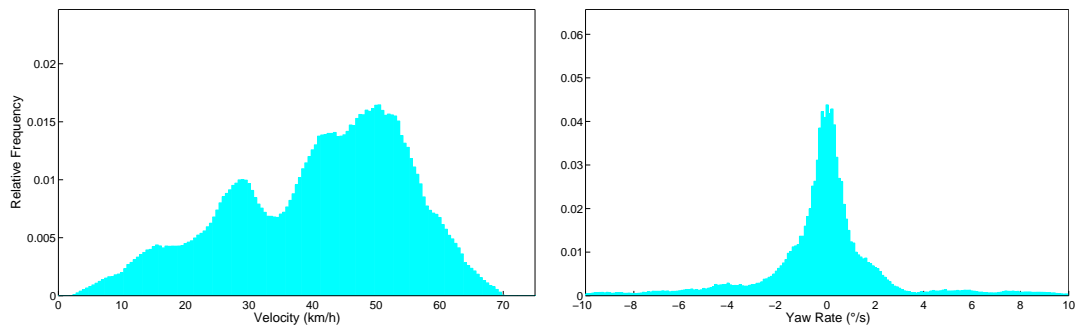

Figure 3.8: Histograms for velocity and yaw rate for one driver of the field study

variable can also play a big role in shaping the histogram. It is necessary to distinguish between a variable *Velocity* that is used in the context of an urban environment as

3. A FUZZY LOGIC BASED DRIVER MODEL

opposed to driving on a highway, each context requiring a different partition of the same variable. The area of application also has to be taken into consideration when deciding the number of Gaussian functions and hence fuzzy sets for a fuzzy variable. For instance, for a driver model whose aim it is to detect emergency braking, it might be enough to partition the variable *Brake Pressure* into two fuzzy sets, one for *low* braking activity, and the other for *high* braking, instead of having a more fine-grained partition for detecting normal stopping maneuvers. The application area determines the level of granularity (see Pedrycz and Gomide [84], p. 61) of the fuzzy variable.

Pedrycz and Gomide also argue that there are general constraints on fuzzy variables if these are to be meaningful for interpretation by human beings (see [84], pp. 59-62). They identify two main criteria, coverage and semantic soundness. Coverage means that for each possible value of a variable there has to be at least one fuzzy set with membership value greater than zero. Semantic soundness corresponds to a number of criteria that together lead to a fuzzy partitioning that can be interpreted by a human being. These criteria are

- **Each set is a unimodal and normal fuzzy set.** This means that a set has only one contiguous area with highest degree of membership, and that maximum membership value must be 1.
- **Fuzzy sets are linguistically meaningful.** This usually means that sets intersect at a membership value of 0.5.
- **The number of sets is kept low.** In order to reflect human cognition, the authors recommend a range of 5 ± 2 sets. For the domain of driver modeling, a range of 2 – 5 is adequate to define interpretable fuzzy variables.

These requirements are usually met when fuzzy sets are designed by a human expert, since the purpose of the criteria is to enforce fuzzy sets that correspond to the human notions of how fuzzy variables should be partitioned. They are more difficult to comply with if the sets are generated automatically from sample data, as in the method developed in this thesis. One example where fuzzy sets are adapted to enhance the performance of the system is shown in Fig. 3.9. Here, the initial membership functions (a) fulfill the above criteria, whereas the final adapted functions (b) do not. The reasoning behind the criteria described above become clear in this example. It is impossible

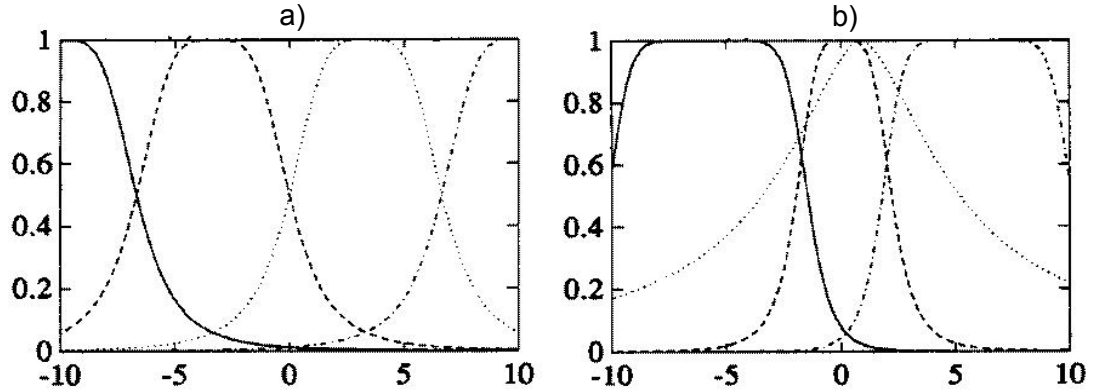

Figure 3.9: Adaptation of fuzzy sets (adapted from [97], p. 672)

to attach any distinctive semantic value to each final fuzzy set, especially for the two largely overlapping sets in the center. Since in the context of driver modeling the fuzzy variables describe human reasoning, any data-based variable generation method needs to fulfill all of the above constraints.

For the task of approximating a histogram with a group of Gaussians, the above criteria have to be taken into consideration when choosing the number of Gaussians. For the example histogram in Fig. 3.5 the following argumentation provides the reasoning behind the choice of number of Gaussians. The task is to find a number of Gaussian functions that define a fuzzy variable representing the speed in an urban environment. Such a histogram usually has one peak at the preferred speed and maybe one more at around 30 km/h. It is semantically admissible to use one Gaussian function for each of these areas, since each has a concrete meaning and for most application areas it is necessary to have a finer-grained granularity than only *medium* and *high Velocity*. Each Gaussian corresponds to one fuzzy set, and if one Gaussian is added at the lower end of the histogram to cover *low Velocity*, the variable consists of three Gaussians. In order to comply with the coverage requirement, another fuzzy set needs to be added at the higher end of the histogram, which will be discussed later. The fuzzy variable ends up having four fuzzy sets, which lies in the admissible range of sets.

Fig. 3.10 shows two resulting GMM's for the example. For each of the histograms, the thin red curves show the approximation achieved by the GMM and the thick green curves depict the three Gaussian functions involved in the mixture. The GMMBayes

3. A FUZZY LOGIC BASED DRIVER MODEL

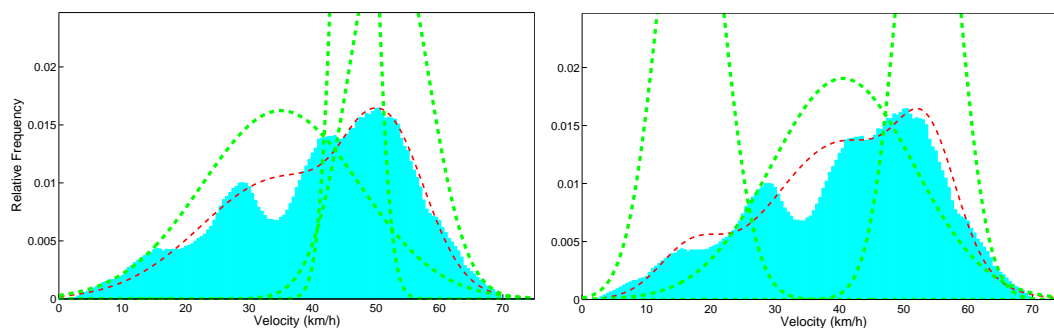

Figure 3.10: Histogram approximation by Gaussian Mixture Models

Toolbox¹ provided by Pekka Paalanen, Joni Kämäräinen and Jarmo Ilonen was used to calculate the GMM, with one small modification. The Expectation-Maximiation (EM) algorithm is a procedure that starts with initial values for the means and variances of the Gaussians and then modified these values iteratively to improve the approximation. The toolbox provides a number of methods for how these starting values are set, for instance by simply taking random values. This is not very efficient and may lead to a collection of Gaussians that do approximate the histogram, but whose corresponding fuzzy sets have limited linguistic meaning. This can be observed in both examples from Fig. 3.10. For the GMM on the left, random initial points were used for the EM algorithm, whereas for the right GMM the starting means were equidistantly positioned between the lowest and highest bins with relative frequencies greater than zero. Even though the right GMM does provide a better partitioning of the histogram, the two rightmost Gaussians both represent parts of what should be one Gaussian representing the preferred speed of the driver.

To improve the probability that the EM algorithm yields a meaningful GMM, two more possibilities how the initial means for the Gaussian distributions are assigned were added to the toolbox. The first one is to simply set the initial values by hand using expert knowledge, in the case of the above velocity histogram perhaps at 15, 30 and 50 km/h. In the second method, a certain percentile value of the underlying histogram is defined as starting value. This is similar to the approach presented in the beginning of this section, with the difference that the percentiles are merely the starting positions

¹<http://www.it.lut.fi/project/gmbayes/>

for an optimization algorithm. In Fig. 3.11 the second method was chosen by fixing the initial means at percentile values 0.25, 0.5 and 0.75. This GMM not only provides a good approximation of the histogram, but also yields a distribution of the Gaussian functions with a clear semantic meaning.

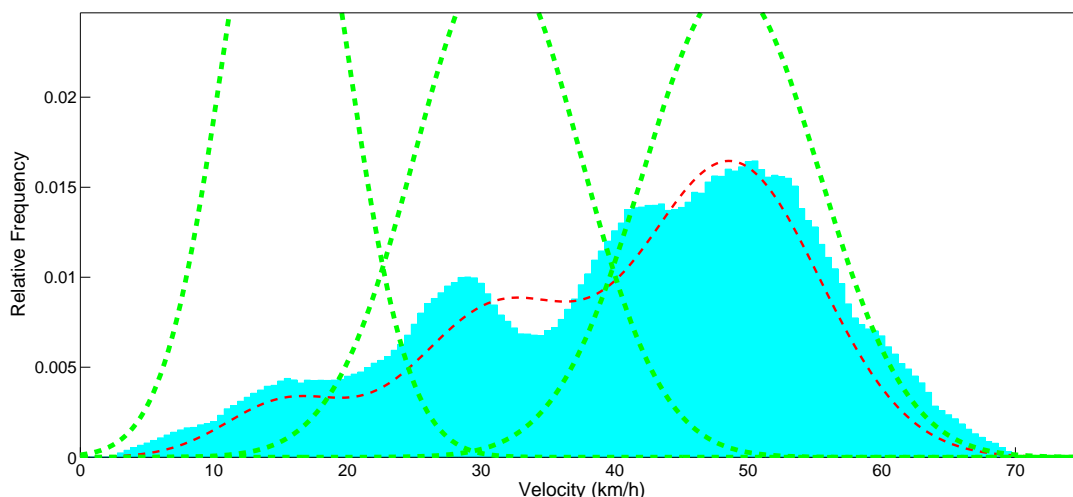

Figure 3.11: Histogram approximation by a Gaussian Mixture Model

3.3.3 Conversion of a Gaussian Mixture Model into a Fuzzy Variable

Given a GMM for the histogram of a signal, the last step in the process is to convert that GMM into a fuzzy variable describing the signal in linguistic terms. The simplest way would be to use the very Gaussian functions as membership functions for their respective fuzzy sets. This can easily be achieved by dividing each Gaussian by its maximum relative frequency, yielding a normal and unimodal fuzzy set. All of the requirements described above are met by the resulting fuzzy variable, except for one important criteria. The fuzzy sets do not intersect at a membership value of 0.5, which limits the interpretability of the fuzzy sets. In the example from Fig. 3.11 the Gaussian functions could easily be transformed in such a way that they do intersect at membership values of 0.5, but this is not generally the case. In chapter 4, GMM's are shown that cannot be transformed into fuzzy sets that intersect at 0.5 without substantial modification in both mean and variance of the distribution, like for instance in Fig. 4.13.

3. A FUZZY LOGIC BASED DRIVER MODEL

In this thesis, the Gaussian functions are transformed into trapezoidal fuzzy sets that comply with all of the above requirements. In principle other membership functions, such as triangular or bell shaped, could also be used. Trapezoids were chosen because they have a plateau of maximum membership, as opposed to just a single value as would be the case with most other membership functions. As was argued in section 3.3.1, a fuzzy set for a *high Velocity* should be defined around the region of the second peak of Fig. 3.5. Suppose a triangular fuzzy set is defined with maximum membership at 49 km/h (the mean of the right Gaussian in Fig. 3.11). There is no intuitive reason why a velocity of, say, 48 km/h would be less a member of the fuzzy set *high* than at 49 km/h, which would be the case for membership functions with only one value at maximum membership. Of course, the membership function should decrease at some point, which is exactly what happens with a trapezoidal membership function. There is also no reason why any other function other than linear should be used for the shoulders. Using *high Velocity* again as an example, it is not intuitive why the membership should rise slowly at the beginning and more quickly the closer the value gets to 49 km/h, as is the case with s-shaped or quadratic functions.

The question is then, how a Gaussian function is converted into a trapezoidal fuzzy set. A trapezoid membership function $\mu(x, a, b, c, d)$ is defined by four parameters a , b , c and d .

$$\mu(x, a, b, c, d) = \begin{cases} 0, & x < a, x > d \\ \frac{x-a}{b-a}, & a \leq x \leq b \\ 1, & b < x < c \\ \frac{d-x}{d-c}, & c \leq x \leq d \end{cases} \quad (3.1)$$

The side bc is called the base, and the sides ab and cd the legs of a trapezoid. These parameters are set based on the Gaussian distributions from the GMM. One straightforward way is to use the mean m and factors of the standard deviation σ as parameters. A trapezoidal function is then defined as follows

$$\mu(x, m, \sigma, f_1, f_2) = \begin{cases} 0, & x < a, x > d, & a = m - f_1 * \sigma, d = m + f_1 * \sigma \\ \frac{x-a}{b-a}, & a \leq x \leq b, & a = m - f_1 * \sigma, b = m - f_2 * \sigma \\ 1, & b < x < c, & b = m - f_2 * \sigma, c = m + f_2 * \sigma \\ \frac{d-x}{d-c}, & c \leq x \leq d, & c = m + f_2 * \sigma, d = m + f_1 * \sigma \end{cases} \quad (3.2)$$

One example for three different possibilities of how trapezoidal fuzzy sets can be constructed in this way are presented in Fig. 3.12. The fuzzy sets for the variable *Velocity* (V) are defined from left to right as $\mu_V^{low}(x, 15.36, 4.56, 2, 1)$, $\mu_V^{medium}(x, 31.23, 6.15, 2, 0.67)$

and $\mu_V^{high}(x, 48.73, 6.56, 2, 0.25)$, respectively. It is not immediately visible which trape-

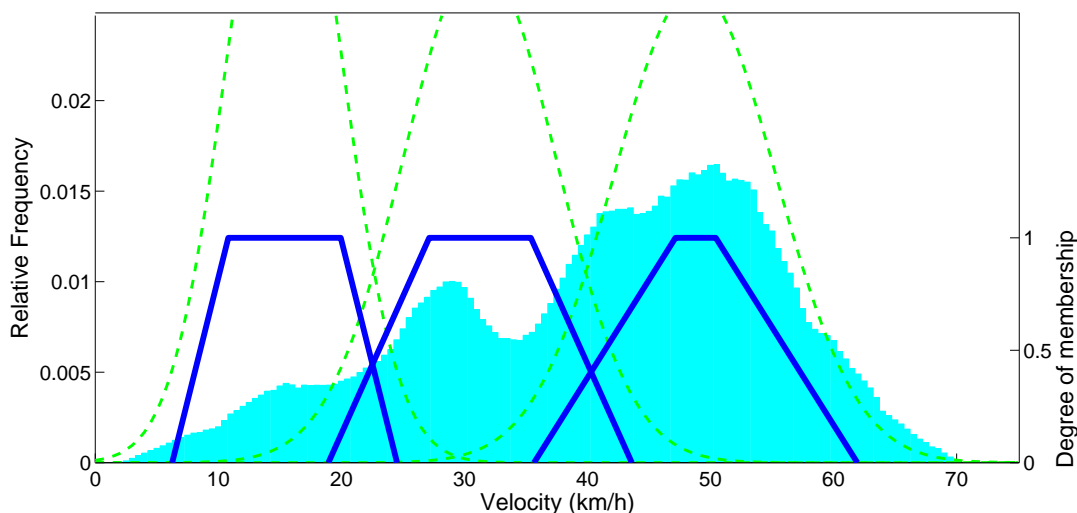

Figure 3.12: Fuzzy sets based on a GMM with variations in σ

zoid is better suited for describing the linguistic term it represents. The fuzzy set μ_V^{high} is arguably least suitable, since only a small fraction of the histogram's peak is regarded as having maximum membership with respect to *high Velocity*. It is not clear, however, which the optimal trapezoid for any of the fuzzy sets could be.

There have been attempts to deal with this problem by describing the information content of fuzzy sets, either by calculating the fuzziness (vagueness) or specificity (imprecision) of the set. According to Klir ([85], pp. 254-258), a general way of describing the fuzziness of a set is to measure the lack of distinction between the set and its complement. The fewer the differences between the two sets, the higher the fuzziness. Using the standard complement and hamming distance, the fuzziness of a set μ in a universe of discourse $X = [i, j]$ is defined as

$$\begin{aligned} F(\mu) &= \int_i^j (1 - |2\mu(x) - 1|) dx \\ &= j - i - \int_i^j (|2\mu(x) - 1|) dx \end{aligned} \quad (3.3)$$

In the case of a trapezoid $\mu(a, b, c, d)$ with a maximum membership value of 1, $F(\mu)$ is

3. A FUZZY LOGIC BASED DRIVER MODEL

easily calculated as

$$\begin{aligned}
 F(\mu) &= j - i - \int_i^a dx - \int_b^c dx - \int_d^j dx - \int_a^b (|2\mu(x) - 1|)dx - \int_c^d (|2\mu(x) - 1|)dx \\
 &= j - i - (a - i) - (c - b) - (j - d) - \frac{b-a}{2} - \frac{d-c}{2} \\
 &= \frac{b-a}{2} + \frac{d-c}{2}
 \end{aligned} \tag{3.4}$$

For the sets defined in Fig. 3.12, the fuzziness values are

$$\begin{aligned}
 F(\mu_V^{low}) &= \frac{10.81 - 6.243}{2} + \frac{24.5 - 19.93}{2} = 4.5685 \\
 F(\mu_V^{medium}) &= \frac{27.11 - 18.92}{2} + \frac{43.55 - 35.36}{2} = 8.19 \\
 F(\mu_V^{high}) &= \frac{47.09 - 35.61}{2} + \frac{61.86 - 50.38}{2} = 11.48
 \end{aligned}$$

The results are plausible, the longer the distances between a and b or between c and d become, the higher is the fuzziness of the set.

Two other measures for fuzziness are that of the energy and entropy of a fuzzy set. They both are calculated through the same integral

$$En(\mu) = \int_X e(\mu(x)) dx \tag{3.5}$$

but differ in the definition of the function $e : [0, 1] \rightarrow [0, 1]$. In the case of the entropy measure, e is monotonically increasing in $[0, \frac{1}{2}]$ and decreasing in $[\frac{1}{2}, 1]$ with $e(0) = e(1) = 0$ and $e(\frac{1}{2}) = 1$. In this case, the membership values around $\frac{1}{2}$ provide the highest degrees of fuzziness. If the piecewise identity function is used for e , the resulting fuzziness measure is the same as that defined by Klir. For the energy measure of fuzziness, e must only be a monotonically increasing function. In the case of e being the identity function, the energy measure is reduced to the mass of the set, calculated through its cardinality

$$|\mu| = \int_X \mu(x) dx \tag{3.6}$$

In the case of a trapezoidal fuzzy set $\mu(a, b, c, d)$, this energy measure is easily calculated as $En(\mu) = \frac{b-a}{2} + \frac{d-c}{2} + (c - b)$. This measure is similar to the one defined in Eq. 3.4, with the distinction that the base increase the fuzziness value. For the example sets in Fig. 3.12, the fuzzy energy values are

$$\begin{aligned}
 En(\mu_V^{low}) &= 13.6885 \\
 En(\mu_V^{medium}) &= 16.44 \\
 En(\mu_V^{high}) &= 14.77
 \end{aligned}$$

The second measure that is often used to characterize fuzzy sets is specificity. The specificity is the measure of how much any given value from the universe of discourse is a representative of the set. For instance, a singleton (a fuzzy set containing only one value) is a very specific set, whereas a fuzzy set $\mu(x) = 1$ has no specificity at all, since each value has the same degree of membership to the set as any other. One possible way to calculate the specificity was developed by Yager [98] as the integral

$$S(\mu) = \int_0^1 \frac{1}{|\mu_\alpha(x)|} d\alpha, \quad (3.7)$$

where $\mu_\alpha(x)$ denotes the α -cut of the set and $|\mu_\alpha(x)|$ the cardinality of that α -cut.

All these measures provide some way of characterizing fuzzy sets and fuzzy variables. However, they do not provide any information about the 'goodness' of the partition. For the above example, it is still not clear which of the three trapezoids is a better fuzzy set. This very much depends on the application context. In the case of driver modeling, the extent to which a human being perceives the fuzziness of a variable is more of a psychological question about human cognition and perception than a computational one. One approach would be to perform a similar field study to that undertaken in [91], asking participants to rate the degrees of membership of certain domain values to individual fuzzy sets and to use that information to find the most human-centered parameters for a trapezoidal fuzzy set.

Due to this difficulty of capturing the 'goodness' of a fuzzy set, in this thesis the parameters of the fuzzy sets were set based on domain knowledge and constraints from the histograms. In the case of driver modeling, having a high degree of fuzziness has two main disadvantages. Since the membership values are used to generate the rules and predict the maneuver (see sections 3.4 and 3.5), sets with high degrees of fuzziness will tend to reduce the prediction capabilities of the driver model. The second drawback is that sets with small regions of high membership have lower generalization capabilities than those with bigger regions. The bases of the trapezoids represent regions where domain values are treated as identical. Hence, for any rule describing a maneuver, there are regions for each of the sets involved in which the rule has equally high truth values. The higher the fuzziness, the smaller these regions become and the closer the values of the respective signals have to be to a specific value to achieve a high truth value for the rule.

3. A FUZZY LOGIC BASED DRIVER MODEL

Keeping that in mind, the factors for the standard deviations that produce the conversion from a Gaussian distribution to a fuzzy set are defined in this thesis as

$$f_1 = 2.0$$

$$f_2 = 0.67448$$

which corresponds to the set μ_V^{medium} in Fig. 3.12. This partition splits the distribution into approximately interquartile ranges, since the base of the resulting trapezoid ($[m - f_2 * \sigma, m + f_2 * \sigma]$) contains 50% and the legs $[m - f_1 * \sigma, m - f_2 * \sigma]$ and $[m + f_2 * \sigma, m + f_1 * \sigma]$ each roughly 22% of the distribution's data. This provides a reasonable trade-off between fuzziness and generalization capabilities. Fig. 3.13 shows the resulting fuzzy variable for the example used in this section.

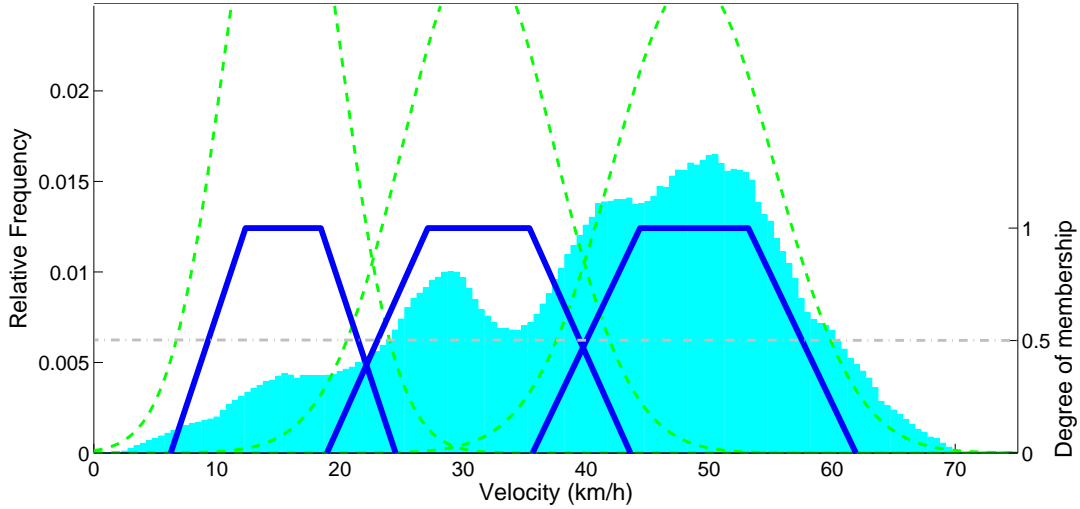

Figure 3.13: Fuzzy sets based on a GMM for the variable velocity

This partition violates the requirements coverage and semantic soundness. The coverage requirement is easily handled by adding fuzzy sets (or modifying existing sets) at the lower and upper end of the distribution. In the above case, it may not be reasonable to add another fuzzy set *very low* before *low* due to the low amount of covered domain values. Instead, the fuzzy set *low* is modified to cover all domain data lower than the trapezoid's right edge. A fuzzy set for *very high Velocity* on the other hand is surely necessary, since it has a clear semantic meaning and covers a certain

3.3 Driver-dependent fuzzy variables

amount of the histogram. This set represents the range of velocity where the driver exceeds his preferred speed. The fuzzy variable violates semantic soundness described in 3.3.2 because the fuzzy sets do not intersect at a membership value of 0.5, thereby restricting the semantic validity of the fuzzy variable. Furthermore, since in the context of this thesis the fuzzy sets denote mutually exclusive concepts, it is also necessary for semantic soundness to end up with a fuzzy variable where the sum of all memberships is always equal to 1 for any domain value, which is also not the case in Fig. 3.13.

To fulfill the requirements, the trapezoids have to be modified in such a way that they do intersect at a membership value of 0.5 and for which the sum of the sets is always 1. This is achieved by fixing the membership value of 0.5 at the intersection point of the Gaussian distributions and modifying the trapezoids accordingly. The intersection points between two Gaussian distributions $g_1(m_1, \sigma_1^2)$ and $g_2(m_2, \sigma_2^2)$ are calculated by

$$i_{1/2} = \frac{-2*m_1*\sigma_2^2+2*m_2*\sigma_1^2}{2*(\sigma_1^2-\sigma_2^2)} \pm \frac{\sqrt{(2*m_1*\sigma_2^2-2*\sigma_1^2*m_2)^2-4*(\sigma_1^2-\sigma_2^2)*(-m_1^2*\sigma_2^2+\sigma_1^2*m_2^2+2*\sigma_1^2*\sigma_2^2*\ln(\frac{\sqrt{\sigma_2^2}}{\sqrt{\sigma_1^2}}))}}{2*(\sigma_1^2-\sigma_2^2)} \quad (3.8)$$

Given the intersection point i that lies in the range $[m_1, m_2]$, the membership values at that point for the fuzzy sets μ_1 and μ_2 based on g_1 and g_2 need to be $\mu_1(i) = \mu_2(i) = 0.5$. To achieve this, the parameters of the trapezoids have to be modified. The fuzzy sets $\mu_1(x, a_1, b_1, c_1, d_1)$ and $\mu_2(x, a_2, b_2, c_2, d_2)$ need to be converted into $\bar{\mu}_1(x, a_1, b_1, \bar{c}_1, \bar{d}_1)$ and $\bar{\mu}_2(x, \bar{a}_2, \bar{b}_2, c_2, d_2)$ in such a way that the following requirements are met

$$\begin{aligned} \bar{\mu}_1(i) &= \bar{\mu}_2(i) = 0.5 \\ \bar{c}_1 &= \bar{a}_2 \\ \bar{d}_1 &= \bar{b}_2 \end{aligned}$$

Modifying the parameters in such a way that the first requirement is met is straightforward. This is done by moving the points d_1 and a_2 as follows

$$\begin{aligned} \bar{d}_1 &= c_1 + 2(i - c_1) \\ \bar{a}_2 &= b_2 - 2(b_2 - i) \end{aligned}$$

However, the sum of memberships at each value for the resulting trapezoids is generally not 1, as was demanded above. To achieve this, the distance $\delta = c_1 - \bar{a}_2 = \bar{d}_1 - b_2$ needs

3. A FUZZY LOGIC BASED DRIVER MODEL

to be eliminated. This can be done by moving points c_1 and b_2 by $\frac{\delta}{2}$ in the respective directions. However, since this alteration modifies the semantics of the fuzzy set, the trapezoid with a higher weight should be modified less than that with a lower weight. The weight of a fuzzy set can be deduced from the amount of the histogram that is covered by its respective Gaussian distribution. The weight of a fuzzy set is defined as the relative frequencies of each bin of the histogram multiplied by the relative frequency of the distribution at that same value as shown in Eq. 3.9.

$$w(\mu_V^s) = \sum_{i=1}^N g_V^s(h_V^x(i)) * h_V^y(i) \quad (3.9)$$

where

$$\begin{aligned} g_V^s &= \text{Gaussian distribution for fuzzy variable } V \text{ and set } s \\ h_V^x(i) &= \text{Domain value for the bin with the index } i \text{ of histogram } h_V \\ h_V^y(i) &= \text{Relative frequency of the bin with index } i \text{ of histogram } h_V \end{aligned}$$

Given this weight calculation, it is possible to calculate the relative weight of the two sets.

$$\begin{aligned} w_1 &= \frac{w(\mu_1)}{w(\mu_1) + w(\mu_2)} \\ w_2 &= \frac{w(\mu_2)}{w(\mu_1) + w(\mu_2)} \end{aligned}$$

Using the relative weight, the new values for c_1 and b_2 are calculated as follows.

$$\begin{aligned} \bar{c}_1 &= c_1 - \delta * w_1 \\ \bar{b}_2 &= b_2 - \delta * w_2 \end{aligned}$$

The final fuzzy variable for the example used throughout this section is depicted in Fig. 3.14. In this case, all requirements mentioned above are fulfilled. Once the variables have been generated for each of the signals used for the prediction of a given maneuver, it is possible to build a rulebase using these fuzzy variables, which is the topic of the next section.

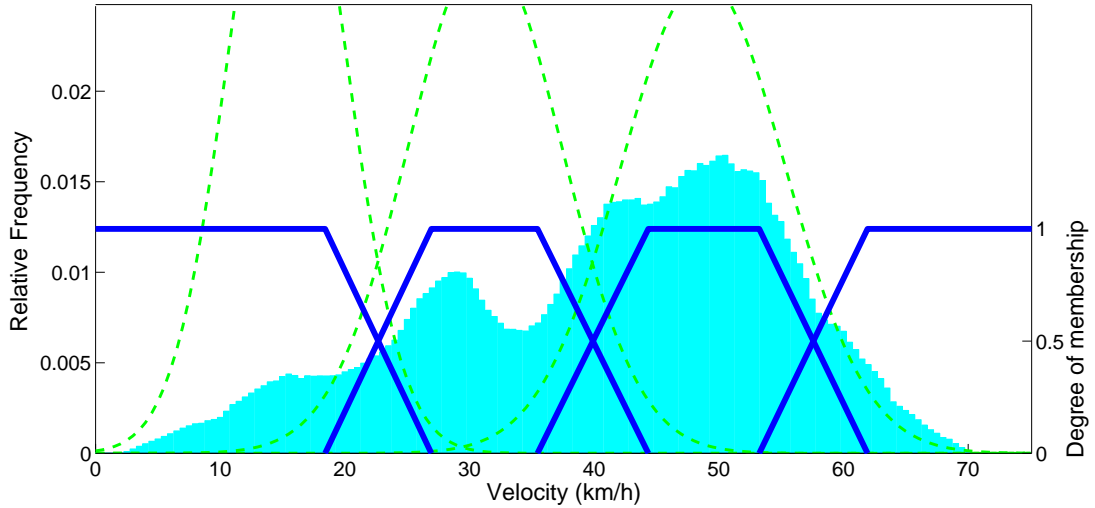

Figure 3.14: Fuzzy variable *Velocity*

3.4 Driver-dependent fuzzy rulebase

Once the fuzzy variables have been defined, a rulebase describing the driver's behavior needs to be generated. As was argued in section 3.1, one possibility is for an expert to design the rulebase that models the behavior. By constructing a theoretical model of the maneuver, this can be translated into a number of rules describing it. Naranjo and colleagues [99] implemented a fuzzy controller for ACC based on nine fuzzy rules that determine the activation of the accelerator and break pedals. With some minor adaptations, this rulebase can be transformed from one controlling the actuators to one describing the maneuver 'car-following', which constitutes the maneuver ACC is based on. Other publications that model car-following behavior by defining a fixed rulebase can be found in [100] and [91], the latter of which also provides rules for lane change maneuvers.

The main problem with this approach is that human drivers differ significantly in their driving behavior. It is in general not possible to define one single rulebase that captures the behavior of each driver appropriately. One preliminary study that was carried out during the course of this thesis supports this claim [101]. In that study, rulebases predicting the stopping behavior in urban environments were generated using

3. A FUZZY LOGIC BASED DRIVER MODEL

data from six drivers of a field study conducted by the Research Division of Volkswagen (see [95]). The prediction accuracy and false-alarm rate for each driver's rulebase was calculated using the cross-validation method described in section 4.2.3. Subsequently, another experiment was carried out, this time using all of the driver's available data to generate the rulebase and taking the data from the remaining five drivers as test set. The differences between the results from each of the experiments indicates how much a rulebase is adapted to the behavior of the individual driver. The results of the study are depicted in Fig. 3.15. These results show that in most cases the prediction rates

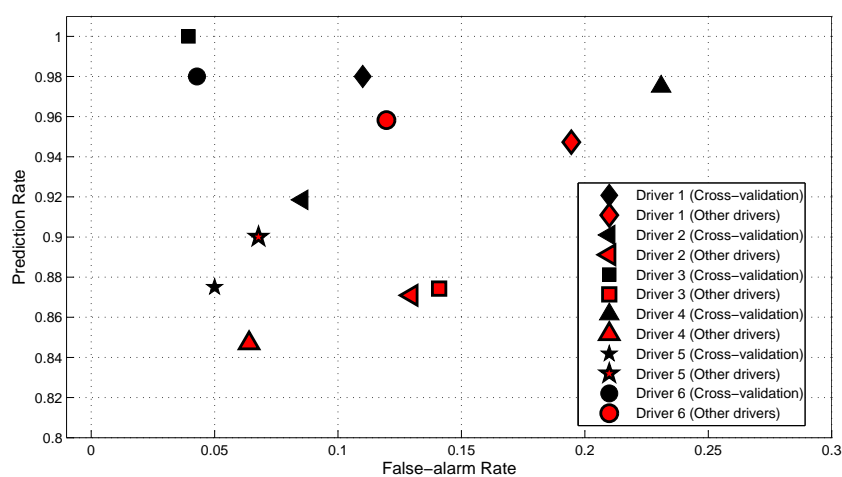

Figure 3.15: Results of the preliminary study, adapted from [101]

are lower and the false-alarm rates higher when predicting data from other drivers, indicating a high specificity of the rulebases.

Therefore, it is necessary to create a fuzzy rulebase that takes the driver's characteristics into account. There are different approaches in this direction, varying in the degree to which the rulebase adapts to the behavior of the individual driver. One possibility is to define separate rulebases for different driver types, setting the driver's type based on the driving behavior. This is done by Holve in [100], where the rules governing the time and strength of deceleration when approaching a slower vehicle are varied depending on the driver type. This driver type is a value ranging from 0 to 10, which is estimated at first and then continuously adapted if the driver's behavior differs from that predicted by the rulebase. Taking the adaptation further, rules defined manually

and others generated from sample maneuvers can be merged in a hybrid approach. In another publication [102], Holve and Protzel implemented a method that controls the accelerator pedal as part of an ACC system, leaving it to the driver to override the accelerator setpoints suggested by the system. Through the feedback from the driver, the model automatically generates a rulebase that describes the driver’s actions. Rules are manually added to the resulting rulebase to cope with incomplete training data and ensure completeness. If no expert knowledge about the maneuver is available or the goal is to fully adapt a rulebase to the driver’s behavior, the rulebase is generated purely on the basis of observed data, which is the method used in this thesis.

In his book [103], Cox describes a rule induction algorithm that lies at the heart of the method developed here. The process behind the algorithm is depicted in Fig. 3.16. In the remainder of the section each part of the process is presented in detail, using as

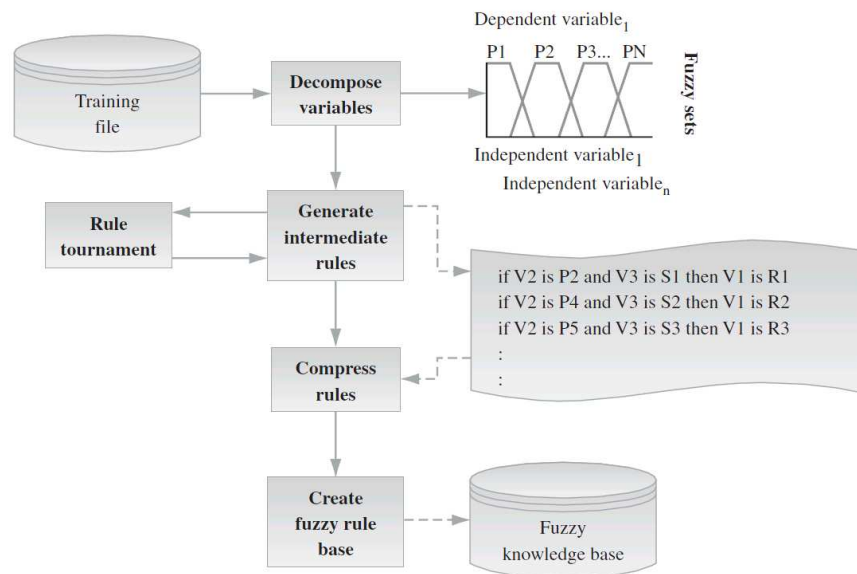

Figure 3.16: The rule induction process, taken from [103]

example an hypothetical stopping maneuver prediction model.

3.4.1 Variable decomposition

How variables are decomposed into fuzzy sets has already been covered in section 3.3. Deciding which variables are suitable to model a given maneuver is not an easy task.

3. A FUZZY LOGIC BASED DRIVER MODEL

An entire field of machine learning, feature selection, devotes itself to answering this question. Feature selection is the technique of selecting a subset of relevant features for building robust learning models. In the domain of driver modeling, the features are all possible signals available in the target vehicle (some of which are mentioned in 4.1.1), and feature selection then selects those that are relevant for the maneuver being modeled. This is beyond the scope of this thesis, however, leaving the choice of relevant variables to the human expert. For the sake of simplicity, only three variables are used in this example. The input variables are

- *Velocity* (V)
- *Time Headway* (T)
- *Brake Pressure* (B)

The fuzzy variables for all three input signals were generated using data from one driver in the field study presented in 4.1, generating the histograms using samples exclusively from urban environments.

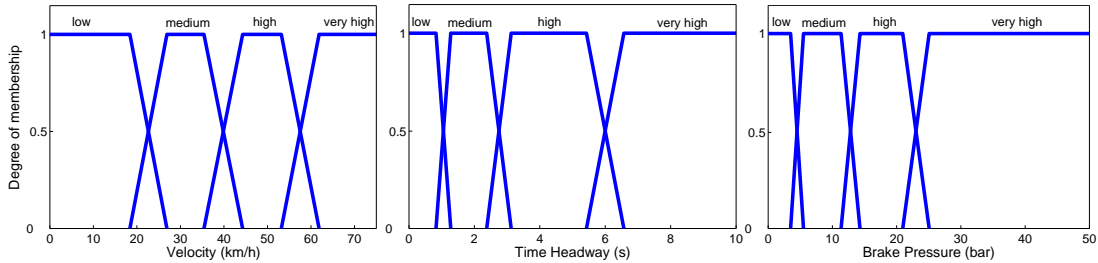

Figure 3.17: Sample fuzzy input variables for stopping maneuver prediction

3.4.2 Intermediate rules generation

Once the fuzzy variables have been defined, rules can be extracted from sample data. Each data point d_i is an (n) -tuple (x_1^i, \dots, x_n^i) consisting of values for the $n - 1$ input variables and the desired value for the output variable *Output* (O). In the case of our stopping maneuver example, the tuples are $(x_V^i, x_T^i, x_B^i, x_O^i)$. The output variable for the sample stopping maneuver prediction model is depicted in Fig. 3.18. It consists of

the singleton sets *stopping* (*s*) and *not stopping* (*ns*) describing class membership for each data sample. Given this output variable, sample data points could for instance

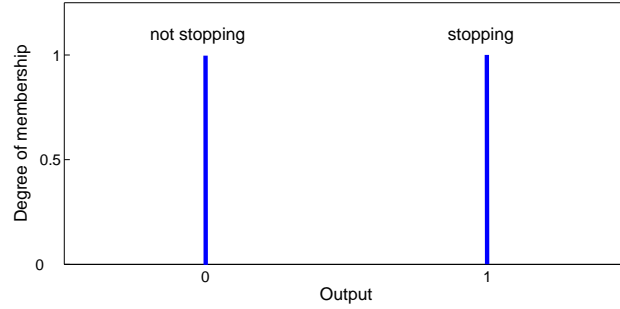

Figure 3.18: Fuzzy output variable for stopping maneuver prediction

be $d_1 = (42.5, 3.1, 16, 1)$, $d_2 = (27, 1.9, 12, 1)$ or $d_3 = (15, 2.1, 0, 0)$. The first two are samples at specific timesteps for the stopping maneuver behind a leading vehicle shown in Fig. 3.19. This is a sample maneuver executed by the driver during the field study. How sample data is created from driving data is covered in more detail in section 4.2.2.

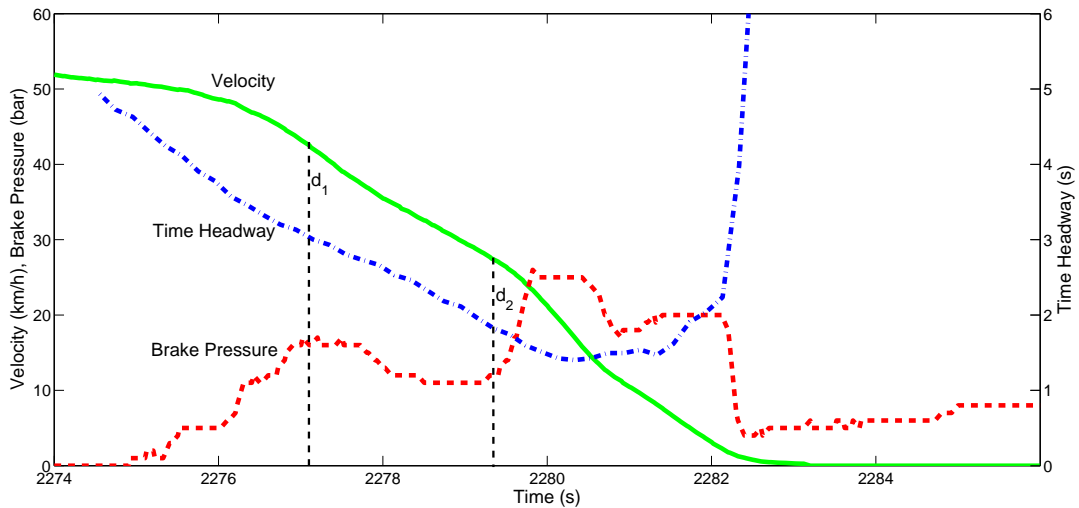

Figure 3.19: Sample data for a stopping maneuver

For each such maneuver, data points are sampled at fixed intervals of 100 ms. The

3. A FUZZY LOGIC BASED DRIVER MODEL

total amount of data points from all sample maneuvers is the positive data, whereas the set of data points from the recorded data not belonging to such a maneuver is the negative data. From that sample data, candidate rules are induced. For each input and the output fuzzy variable, the fuzzy set with the highest degree of membership is chosen as described in section 3.2. The resulting tuples from the data points shown above are $r_1 = (\mu_V^h, \mu_T^h, \mu_B^h, \mu_O^s)$, $r_2 = (\mu_V^m, \mu_T^m, \mu_B^m, \mu_O^s)$ and $r_3 = (\mu_V^l, \mu_T^m, \mu_B^l, \mu_O^{ns})$. Each of these tuples represents a rule that can become part of the rulebase describing a stopping maneuver. The rule r_1 written out is

IF V is *high* **AND** T is *high* **AND** B is *high*
THEN O is *stopping*

The rules generated in this manner are only candidate rules for the rulebase, since there is the possibility of having conflicting rules. Conflicting rules are those with the same antecedent but differing consequents. In the case of a stopping maneuver prediction, it can be argued that the antecedent of r_1 , $(\mu_V^h, \mu_T^h, \mu_B^h)$, need not always be classified as a stopping maneuver. The data could for instance appear in a situation where the driver only brakes very briefly due to a leading vehicle turning at an intersection. In the case of conflicting rules, one of the rules needs to be chosen, which is the task of the rule tournament.

3.4.3 Rule tournament

In order to end up with a consistent rulebase, conflicting rules have to be disambiguated. This is done by removing all but one rule with the same antecedent. Given the two rules $r_1 = (\mu_V^h, \mu_T^h, \mu_B^h, \mu_O^s)$ and $r_4 = (\mu_V^h, \mu_T^h, \mu_B^h, \mu_O^{ns})$, one of them needs to be removed if both rules were generated from input data. In order to do so, the effectiveness of a rule needs to be calculated. Cox defines the effectiveness as the product of the membership values assigned by the fuzzy sets μ_V^s of rule r_j to the input vector d_i

$$E(r_j, d_i) = \prod_{k=1}^n \mu_{V_k}^{S_k}(x_k^i) \quad (3.10)$$

For r_1 and d_1 , the effectiveness value is

$$\begin{aligned} E(r_1, d_1) &= \mu_V^h(42.5) * \mu_T^h(3.1) * \mu_B^h(16) * \mu_O^s(1) \\ &= 0.79 * 1.0 * 1.0 * 1.0 = 0.79 \end{aligned}$$

Suppose now that r_1 was generated from d_1 and the conflicting rule r_4 from data point $d_4 = (47, 3.0, 18, 0)$. The effectiveness values for the rules are

$$\begin{aligned} E(r_1, d_1) &= 0.79 \\ E(r_4, d_4) &= \mu_V^h(47) * \mu_T^h(3.0) * \mu_B^m(18) * \mu_O^{ns}(0) \\ &= 1.0 * 0.84 * 1.0 * 1.0 = 0.84 \end{aligned}$$

In this case, rule r_4 would be chosen over rule r_1 given its higher effectiveness value. As new data arrives and rules are generated, the effectiveness of the new rule is calculated and a rule tournament between competing rules conducted, leading to a consistent rulebase containing rules of high effectiveness. Cox also introduces another measure he calls a belief function $B(d_i)$. This function measures the contribution of the input data associated with a rule as a value in $[0, 1]$ and is a domain dependent function defined by an expert. This is used to calculate the final quality of a rule, which is the product of effectiveness and belief

$$Q(r_j, d_i) = E(r_j, d_i) * B(d_i) \tag{3.11}$$

Since $B(d_i)$ is highly domain-dependent, there is no reference in the book as to how it can be calculated in practice. It is only stated that it is often useful to add specific domain knowledge about the data to the calculation of the rule's quality. An example for a belief function applicable to a rule r_j as opposed to a data point d_i is presented in section 3.5.1.

3.4.4 Rule compression

The rule tournament is one of the methods that can be used to compress the rulebase. Not only does it eliminate conflicts, but since only one rule with a given antecedent can be part of the rulebase, a potentially substantial number of candidate rules are removed from the database. Cox also mentions other possibilities for reducing the size of the rulebase. The simplest one is to remove duplicates by keeping only the rule with the highest effectiveness. Another method is to exclude rules that lack enough support by the data. This can be done by setting a minimum threshold and removing rules that have a lower number of data points supporting it than specified by that threshold. Alternatively, the minimum threshold can be defined as a percentage value, in which

3. A FUZZY LOGIC BASED DRIVER MODEL

case only those rules with a number of input vectors that exceeds a given percentage of the data space are kept. The remaining rules following compression form the final knowledge base.

3.5 Driver-dependent fuzzy state machine

The rulebase generation process described above is the basis for the method developed in this thesis, with two main differences. The first is related to the calculation of the effectiveness (see Eq. 3.10). In the context of driving maneuver prediction, a different method is better suited for the calculation of the effectiveness, as will be discussed in section 3.5.1. The second difference is how rules are removed from the rulebase. The different calculation of the effectiveness and the inclusion of a belief measure for a rule r_j leads to a different methodology for removing rules than that described in section 3.4.4.

Since a driving maneuver is a task consisting of a number of sequential sub-tasks, it is better described not only as a rulebase of individual measurements, but as a sequence of rules that as a whole represent the maneuver. For this reason, a state machine with individual states representing fuzzy rules is generated from driving data. This state machine is the model that ultimately describes driving behavior. Thus, not only are individual states (rules) used to predict a maneuver, but also sequence of states as defined by the state machine. In the remainder of the chapter, the effectiveness and belief calculation and rule compression methods (section 3.5.1) as well as the generation of a fuzzy state machine and subsequent maneuver prediction computation (section 3.5.2) are discussed.

3.5.1 Rule effectiveness and belief calculation

The main disadvantage of the effectiveness calculation method described by Cox is the strong effect low membership values have on the effectiveness of a rule. Consider for instance a rule with 5 input variables that describes a driving maneuver. If a data point leads to a membership value of 0.9 for 4 of them, and of 0.5 for the remaining variable, the resulting effectiveness of the rule will be only 0.32, even though most of the data supports the rule. Since the effectiveness is used in the prediction calculation, this data

3.5 Driver-dependent fuzzy state machine

point would only lead to the prediction of the relevant maneuver with a quality of at most 0.32.

To overcome this problem, a different effectiveness calculation is used based on the harmonic mean. The harmonic mean is one of the three classic mean calculations together with the arithmetic and geometric means. Given n positive real numbers x_1, \dots, x_n , the harmonic mean is calculated as

$$H = \frac{n}{\sum_{i=1}^n \frac{1}{x_i}} \quad (3.12)$$

To calculate the effectiveness, the harmonic mean of the membership values of the rule's fuzzy sets is computed as

$$E(r_j, d_i) = \begin{cases} H(r_j, d_i) \\ = \left\{ \begin{array}{ll} \frac{n}{\sum_{k=1}^n \frac{1}{\mu_{V_k}^{s_k}(x_k^i)}} & , \text{ if } \forall_k : \mu_{V_k}^{s_k}(x_k^i) > 0 \\ 0 & , \text{ otherwise} \end{array} \right. \end{cases} \quad (3.13)$$

When using Eq. 3.13, the effectiveness of the above example becomes 0.77, which is substantially higher than the original value of 0.32. However, since each of the fuzzy variables in the rule is relevant for the prediction, small membership values should nevertheless to small effectiveness values. The harmonic mean offers a good trade-off between high effectiveness given a low number of sets with relatively low values, and low effectiveness when at least one variable has a very low membership. The relationship between membership value and effectiveness is presented in Fig. 3.20. Different effectiveness calculations for 5 variables were computed, where 4 of them had a fixed membership value of 0.9, and the last one varied from 0 to 1. The bold curve in the middle is the harmonic mean, while those above are the two other classical means and the two below the minimum and product, respectively. It can be seen that the harmonic mean has a substantially higher value than the product, the original effectiveness proposed by Cox. As opposed to the effectiveness when calculated using the arithmetic or geometric means, the values for the harmonic mean are still low when the varying variable has a low membership value.

The rule tournament and rule compression mechanisms as proposed by Cox are performed on the basis of the effectiveness calculation. In the process of disambiguating the rules, only one of the rules with the same antecedent is kept in the rulebase and the others removed. In the case of predicting driving maneuvers this is an undesirable

3. A FUZZY LOGIC BASED DRIVER MODEL

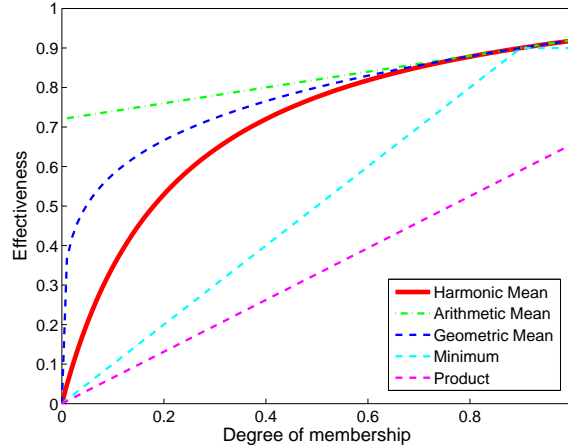

Figure 3.20: Harmonic mean of 5 variables

behavior, since most antecedents of a rule do not appear exclusively in one type of maneuver and no other. Chances are that a rule is classified as not belonging to the maneuver being modeled on the grounds that a negative data point having the same antecedent and higher effectiveness is kept in the rulebase. If the amount of data supporting the statement that the rule belongs to the maneuver is higher than the amount of data denying it, that might be the wrong decision. The argument is also true when a positive rule with only few data points supporting it but with high effectiveness is kept, even if many negative sample data points generating the same rule antecedent exist in the data. This leads to incorrect classifications, since many negative data points exist in the data that activate the rule. It is hence necessary to take the total amount of data supporting or not supporting a rule into account. In order to provide a measure of how good a rule is at modeling the maneuver, a belief function that weighs both the positive and negative data points is proposed. This belief measure together with the effectiveness of a rule provide the quality of a rule as defined in Eq. 3.11. The quality is ultimately used to compress the rulebase and predict maneuvers based on new data samples.

The belief function in the context of the driver model developed here does not assign a belief value to data points, but rather to the rules in the rulebase. The function $B(r_i)$ is based on the F-Measure, a measure with origin in information theory. The F-Measure gives a weighed harmonic mean of two values, recall and precision. In the context of

classification problems such as maneuver prediction, recall represents the true positive rate

$$recall_1(i) = \frac{t_p^i}{t_p^i + f_n^i} \quad (3.14)$$

where

$$\begin{aligned} t_p^i &= \text{positive data correctly classified by classifier } i \\ f_n^i &= \text{positive data not classified by classifier } i \end{aligned}$$

Precision is the ratio between the amount of positive data classified correctly and the number of false positives

$$precision_1(i) = \frac{t_p^i}{t_p^i + f_p^i} \quad (3.15)$$

where

$$f_p^i = \text{negative samples classified by classifier } i$$

In order to calculate the belief of a rule r_i , recall and precision need to be defined in the context of driver modeling. Using the standard interpretation, recall is the ratio between the positive data points activating the rule and all positive data points. The fewer data points exist supporting r_i , the lower its recall. Given that each maneuver consists of a sequence of individual rules, no single rule can have a very high recall value. This is not desirable, since low recall values also lead to low belief and hence quality values, which in turn might lead to the elimination from the rulebase or, since the quality of a rule effects the prediction of a maneuver, low prediction values. Therefore, a different calculation for recall is defined as

$$recall_2(r_i) = \frac{t_p^{r_i}}{\max(t_p^{r_i}, \bar{t}_p)} \quad (3.16)$$

where

$$\bar{t}_p = \text{mean number of positive data points of all rules}$$

Using $recall_2(r_i)$, each rule r_i with a higher number of positive data points than the mean number of positive samples of all rules has a recall value of 1, and only those rules with a lower number of positive data supporting the rule get a lower recall value.

An additional data source that can influence the degree of belief in a rule is its effectiveness. Each data point supporting rule r_i activates it by a value between 0 and

3. A FUZZY LOGIC BASED DRIVER MODEL

1 as computed by Eq. 3.13. The higher the effectiveness values are for rule r_i compared to those of data samples activating other positive rules, the higher the recall value for rule r_i should be. Including the data from effectiveness, the final recall is computed as

$$recall(r_i) = \frac{\overline{a_p^{r_i}} * t_p^i}{max(\overline{a_p^{r_i}} * t_p^{r_i}, \overline{a_p} * \overline{t_p})} \quad (3.17)$$

where

$$\begin{aligned} \overline{a_p^{r_i}} &= \text{mean effectiveness of the positive samples of rule } r_i \\ \overline{a_p} &= \text{mean effectiveness of the positive samples of all rules} \end{aligned}$$

It is recommendable to consider a rule's effectiveness values for the calculation of precision as well. Likewise, larger mean truth values for positive or negative data should lead to larger or lower precision values. The final precision of a rule is

$$precision(r_i) = \frac{\overline{a_p^{r_i}} * t_p^{r_i}}{\overline{a_p^{r_i}} * t_p^{r_i} + \overline{a_n^{r_i}} * f_p^{r_i}} \quad (3.18)$$

where

$$\overline{a_n^{r_i}} = \text{mean effectiveness of all false positive samples of rule } r_i$$

Given these two values, the belief of a rule using the F-measure is computed as

$$\begin{aligned} B(r_i) &= F_\beta(r_i) \\ &= (1 + \beta^2) \frac{precision(r_i) * recall(r_i)}{\beta^2 * precision(r_i) + recall(r_i)} \end{aligned} \quad (3.19)$$

The parameter β is used to assign different weights to each of the two values. Setting $\alpha = 2$ for instance weighs recall twice as much as precision and $\beta = \frac{1}{2}$ does the opposite. There is no optimal value for β , it is largely dependent on the purpose of the F-Measure. In the case of the driver model developed here, β influences the ratio between the likelihoods of correctly classifying a maneuver and that of mistakenly classifying an unrelated driving scenario as a correct maneuver. In general, a value favoring precision will tend to favor rules that have a low chance of predicting a maneuver under the wrong circumstances, whereas β values favoring recall will favor rules that are typical for the maneuver being modeled, even if these also occur in other driving situations. Which of the two is more important depends on the purpose of the driver model. An example

where precision is substantially more important than recall is provided in section 5.3.2, where the value for β is set to $\beta = 0.1$ to reflect that importance. Even though in the evaluation of the driver model in chapter 4 no precise application area is defined, the same value $\beta = 0.1$ is used, since in general in the domain of maneuver prediction it is more important to have a high prediction rate than a low false alarm rate.

3.5.2 Fuzzy state machine calculation

It is difficult to predict a driving maneuver based only on data available at any single point in time. As was already mentioned, driving maneuvers are basically sequences of rules describing single steps of each individual maneuver. Fig. 3.21 displays the sequence of rules for the sample stopping maneuver from Fig. 3.19. Each state represents a single rule with numerical representations for its corresponding fuzzy sets for *Velocity*, *Time Headway* and *Brake Pressure*, respectively. The highlighted state in the middle of the sequence corresponds to the data point d_2 .

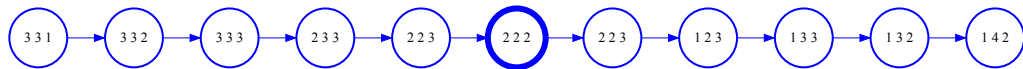

Figure 3.21: Sequence of states representing a stopping maneuver

This is of course a very simple state machine consisting of only one path. The more example maneuvers are available for training and the more these differ from one another, the bigger and more complex the state machine becomes. Fig. 3.22 displays one such state machine based on 7 maneuvers which is described in more detail in section 4.2.4. It is logical to assign probabilities to the transitions of the state machine and to use these probabilities in combination with the belief and effectiveness values of the rules involved in the transition to predict a maneuver. It is, however, not enough to assign probabilities to individual transitions based on the assumption that the current state only depends on the previous state (the Markov property mentioned in section 2.4.3). This need not be the case in the modeling of driving maneuvers, where a state can depend on a sequence of previous states.

In this case, the evaluation of a sufficiently long sequence of states is recommendable to achieve a high prediction accuracy. For the highlighted state $(\mu_V^m, \mu_T^m, \mu_B^m)$ in

3. A FUZZY LOGIC BASED DRIVER MODEL

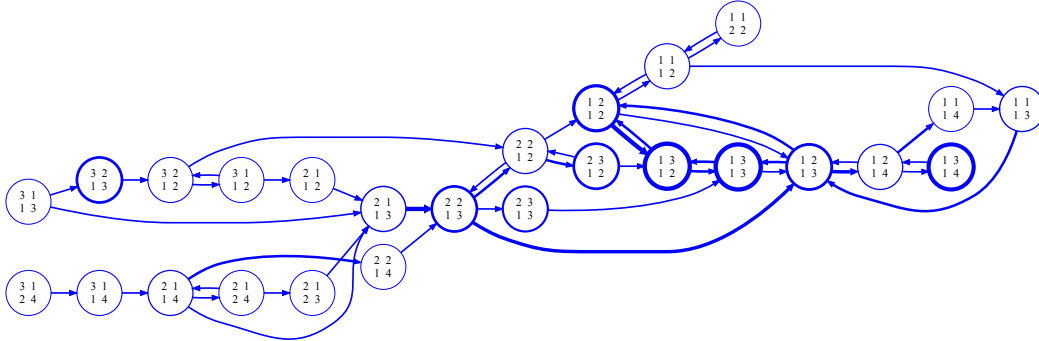

Figure 3.22: State machine for stopping maneuver prediction

the sequence from Fig. 3.21, it need not necessarily be behavior typical for stopping maneuvers. It could very well be a short tip on the brake pedal with no intention of stopping. If a sufficiently large number of similar situations occur in unrelated driving situations in the learning phase, this rule will be a poor predictor for stopping maneuvers. The picture changes, however, if the previous steps are taken into consideration. Before entering that state, the driver had already braked with a *high* brake pressure and reduced both the velocity of his vehicle and the time headway to the car in front. This sequence of events is less likely to happen in an unrelated maneuver, thus increasing the likelihood of the driver actually performing a stopping maneuver.

It is not clear, however, how long such a sequence needs to be, since this depends on the complexity of the maneuver, the number of variables involved and the level of granularity of the sets. The above sequence already consists of 11 states, even though it is a relatively simple maneuver with a low number of variables. Therefore, in order to keep the model as general as possible, it is necessary to simultaneously consider sequences of varying lengths. In this thesis, sequences of lengths between one and six were chosen. Longer sequences turned out to be too specific in the sense that no maneuver except for the one that generated it had the same sequence, rendering it useless for prediction purposes. Instead of calculating only the belief values of a single rule r_j , the belief value of a sequence of rules s_i can be calculated. This belief value, together with the effectiveness value of the current rule, are used to predict new data.

In order to calculate the belief value of a sequence, for each sample point d_i the

sequences that lead to the corresponding state need to be determined. For data point d_2 , the sequences are depicted in Fig. 3.23. During the learning period, each sample

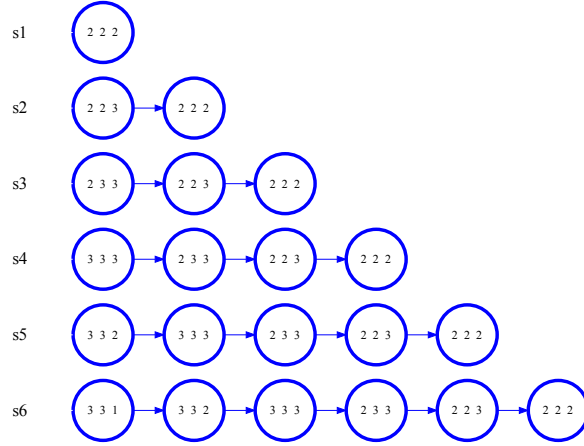

Figure 3.23: Stopping sequences for data point d_2

adds to the number of data points for positive or negative occurrences of a sequence. In the case of sample d_2 , for instance, the number of positive samples are increased by one and $E((\mu_V^m, \mu_T^m, \mu_B^m, \mu_O^s), d_2)$ included in the arithmetic mean of the effectiveness of each of the sequences from Fig. 3.23. After the learning phase, each state contains a set of sequences with up to six states that lead to that particular state in any sample maneuver of the training data. Each of these sequences contains the number of positive and negative data samples and mean effectiveness values for that sequence of states. From those values, the recall and precision values for a sequence of states are calculated in an analogous manner to that of single rules. In this case, recall is defined as

$$recall(s_i) = \frac{\overline{a_p^{s_i}} * t_p^{s_i}}{\max(\overline{a_p^{s_i}} * t_p^{s_i}, \overline{a_p^{|s_i|}} * t_p^{|s_i|})} \quad (3.20)$$

where

$$\begin{aligned} \overline{a_p^{s_i}} &= \text{mean effectiveness of positive samples of sequence } s_i \\ \overline{a_p^{|s_i|}} &= \text{mean effectiveness of positive samples of sequences of length } |s_i| \\ t_p^{s_i} &= \text{number of positive samples of sequence } s_i \\ \overline{t_p^{|s_i|}} &= \text{mean number of positive samples of sequences of length } |s_i| \end{aligned}$$

3. A FUZZY LOGIC BASED DRIVER MODEL

Precision in the context of state sequences is defined as

$$precision(s_i) = \frac{\overline{a_p^{s_i}} * t_p^{s_i}}{\overline{a_p^{s_i}} * t_p^{s_i} + \overline{a_n^{s_i}} * f_p^{s_i}} \quad (3.21)$$

where

$$\begin{aligned} \overline{a_n^{s_i}} &= \text{mean effectiveness of false positive samples of sequence } s_i \\ f_p^{s_i} &= \text{number of false positive samples of sequence } s_i \end{aligned}$$

For sequence s_1 in Fig. 3.23, the values for $\overline{t_p^{|s_1|}}$ and $\overline{a_p^{|s_1|}}$ are identical to the values $\overline{t_p}$ and $\overline{a_p}$ of rule r_2 . For sequence s_5 , on the other hand, $\overline{t_p^{|s_5|}}$ and $\overline{a_p^{|s_5|}}$ are the mean size and effectiveness of all sequences of length $|s_i| = 5$, which differ substantially from those of r_2 . If that sequence of states is typical for the driver's stopping behavior, then $recall(s_5)$ and $precision(s_5)$ are more likely to produce a higher belief value than $recall(s_1)$ and $precision(s_1)$.

When the learning phase is concluded, a state machine consisting of states and transitions between states that model the training maneuvers has been generated. This state machine can be used to predict subsequent maneuvers. When a new data point d_i arrives, the most active rule r_j and its corresponding state st_j in the state machine are identified. If st_j is not part of the state machine, the data does not belong to the maneuver type being modeled and the prediction value is $P(d_i) = 0$. Otherwise, all subsequences of length not higher than six of the current sequence of states are computed and compared to the set of sequences stored in st_j . The set of identical sequences, $\{s_1, \dots, s_m\}$, are used to calculate the final prediction value of the data point as

$$P(d_i) = E(r_j, d_i) * \max_{k=1}^m (B(s_k)) \quad (3.22)$$

The effectiveness value states how well the data matches a rule in the rulebase, and the belief value measures how typical the current state sequence is for the specific type of driving maneuver being modeled. The closer the value $P(d_i)$ is to the maximum value of 1.0, the higher the effectiveness and belief values need to be, and hence the more likely the data belongs to a positive maneuver.

4

Evaluation of the driver model

In the previous chapter the driver model developed in this thesis was presented. To illustrate the method, a very simple model consisting of three variables was used to generate a state machine for stopping maneuver prediction. In this chapter, the method is applied to two common types of driving maneuvers found under regular driving conditions. For the purpose of generating data for the evaluation, a field study was designed and carried out. The field study is presented in section 4.1, followed by the application and evaluation of the method on the two sample maneuver types using data from the study in sections 4.2 and 4.3.

4.1 Driver modeling field study

In order to analyze the performance of the driver model, a field study was designed and carried out. The aim of the field study was to generate data from various drivers in normal driving situations. The design and realization of the field study was to a large extent implemented in the context of a master's thesis [104]. From the data acquired in the study, driver models can be generated for designated maneuvers and their performance evaluated.

4.1.1 The vehicular test platform

The field study was carried out with a Volkswagen Passat CC belonging to the Research Division of the Volkswagen Group located in Wolfsburg, Germany. As a research vehicle, the test vehicle is equipped with a number of additional sensors and a data

4. EVALUATION OF THE DRIVER MODEL

acquisition system for recording vehicle and sensor information. The data collected in the study was preprocessed, stored in a database and then used for the evaluation of the driver modeling method. Fig. 4.1 shows the test platform and the type of information recorded for the field study. Sample signals from each of the modules illustrate the type of information that was recorded.

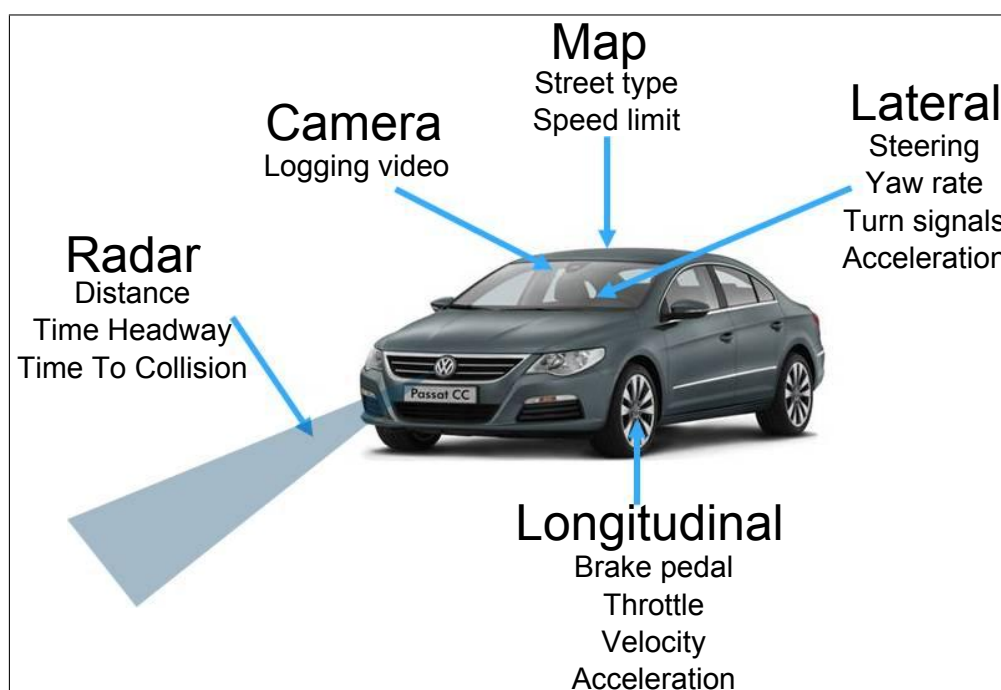

Figure 4.1: The test platform

- **Longitudinal control.** This module recorded the available data that can be used to describe how the driver executes the longitudinal control of the vehicle. Besides from obvious signals such as vehicle speed or brake and throttle positions, longitudinal variables included gear position, longitudinal acceleration, ABS (see 1.4.4) or ASR activation. From the pedal information, the velocity with which brake and accelerator pedals were pressed or released was also calculated.
- **Lateral control.** The data relevant for the lateral control of the vehicle was recorded by this module. The most important signals are steering wheel position, steering velocity, yaw rate and indicator signals. The lateral stability of the vehicle was also recorded through lateral acceleration and ESC (see 1.4.4) activation.

- **Logging camera.** The purpose of the logging camera was to better understand a given driving situation during evaluation. Since environmental data was limited to one range sensor and limited information from a digital map, it is difficult to interpret complex driving situations correctly based only on the available data. Therefore, at least one camera covering the vehicle's front is recommendable. The camera installed in the test vehicle was a mvBlueFOX USB camera from Matrix Vision¹ mounted behind the rearview mirror. A screenshot of the camera's output is shown in Fig. 4.2.



Figure 4.2: Image taken by the vehicle's logging camera

- **Digital map.** A digital map was used to provide additional information about the environment. The ADAS RP² platform from NAVTEQ was used for this purpose. From the data available on that platform, only data usually available on standard navigation systems was used. As the most important information, the

¹<http://www.matrix-vision.de>

²http://www.nn4d.com/site/global/learn/product_catalog/navteq/adas/50_tools_and_support/60_adas_rp/p_adas_research_platform.jsp

4. EVALUATION OF THE DRIVER MODEL

current road type and speed limits were extracted from the map. This information is relevant for the generation of histograms (see 3.3.1) for a variety of signals and hence influences the creation of the fuzzy variables. Additional signals were the curvature of the current road segment, the number of lanes in each direction of travel and the distance to the next segment. Segment are separated through a variety of factors, such as intersections, traffic lights or changing road curvatures. As with the logging camera, raw GPS data was also recorded to provide reasonably accurate position information at any given time to ease subsequent analysis.

- **Range sensor.** A long range radar was used to detect obstacles in front of the vehicle and provide information about their position, velocities and widths. The sensor integrated in the vehicle is the ARS300¹ radar by Continental. The advantage of this sensor is that it has a wide opening angle at close range and yet can identify objects at a distance of around 200 m (see Fig. 4.3, taken from the sensor's data sheet²), a combination that is usually not found in traditional short range or long range radars. From the vehicle's velocity and direction of travel, together with the information from the radar, useful data for driving modeling can be generated. The TTC, Time Headway and predicted collision position were calculated and stored in the database. Measurements from the radar and the data extracted from the digital map provide all the information necessary to distinguish between the driving scenarios defined in section 2.1.

4.1.2 The driving route

The driving route the subjects had to follow was designed to cover a wide range of driving scenarios. It was divided into individual parts of roughly equal driving time for urban, rural and highway roads. The total length of the route was 105 km. It took each subject approximately 30 minutes to conclude each section, variations depending mostly on traffic and environmental conditions. The complete driving route is depicted

¹http://www.conti-online.com/generator/www/de/en/continental/industrial_sensors/themes/ars_300/ars_300_en.html

²http://www.conti-online.com/generator/www/de/en/continental/industrial_sensors/themes/download/ars_300_datasheet_100429_v02_en.pdf

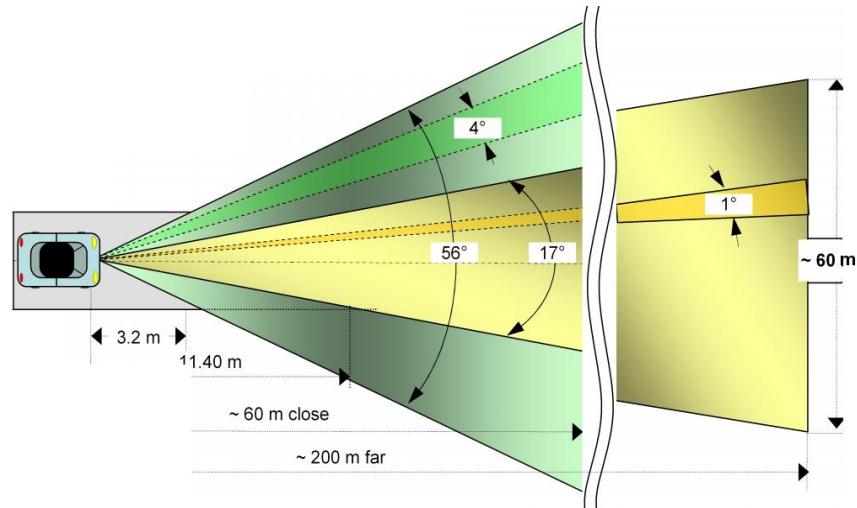

Figure 4.3: Range and opening angles of the ARS 300

on the map made with OpenStreetMap¹ in Fig. 4.4. The urban section, which is of prime interest in this thesis, is enclosed by the black lines.

The first element of the route was the highway section. The chosen highway was the A39 connecting Wolfsburg and Braunschweig. This was chosen for two main reasons. Firstly, the 44 km of the test route exhibit only minor variations. Most of the road has two lanes in each direction and no speed limit, so there is no need of substantial segmentation of the data by situational conditions. During the time of testing, there was a small construction site, which provides potentially useful information about how behavior changes according to the change in driving condition. Secondly, the route ended in the city of Braunschweig, which provides a good urban scenario with a higher variety of driving tasks and traffic conditions than any other location in the vicinity.

The second part lead the subjects through the city of Braunschweig. The focus of this part was to confront the driver with a variety of driving situations such as stopping at traffic lights, following vehicles or turning at intersections. Around 87% (13,4 km) of the path consisted of main streets with a speed limit of 50 km/h and normal to high traffic circulation. In order to analyze change in behavior when driving in residential areas, the remaining 13% of the route conducted the driver through a residential zone with a speed limit of 30 km/h and less amount of traffic.

¹<http://www.openstreetmap.org/>

4. EVALUATION OF THE DRIVER MODEL

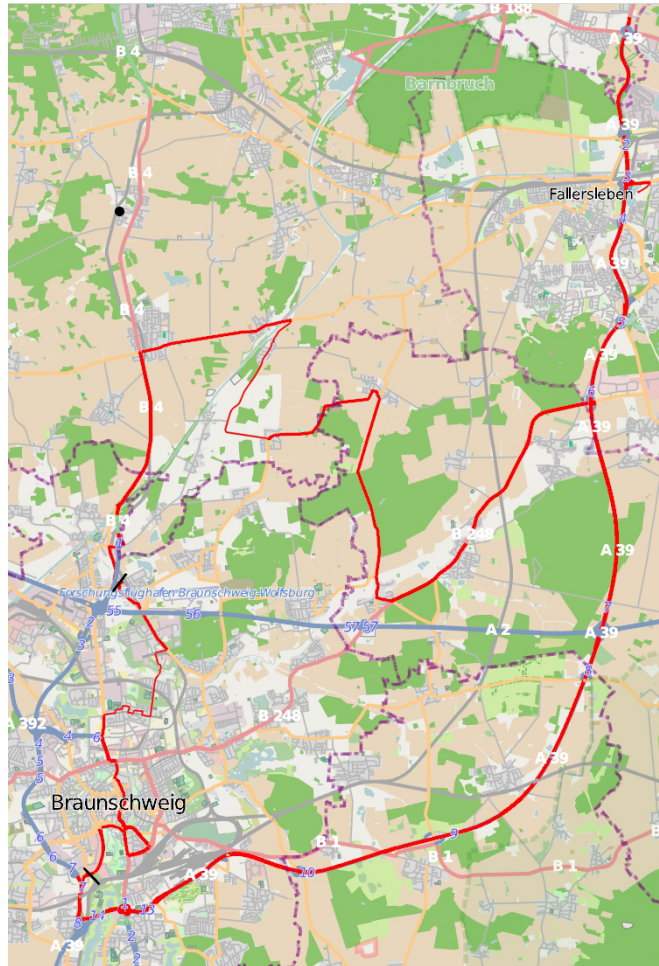

Figure 4.4: Driving route of the field study

After leaving the residential area, the route continued on a rural road. From the total of about 40 km, 50% took place on roads with a speed limit of 100 km/h (the common limit on German rural roads) with one lane in each direction. In order to be able to analyze the distinction in behavior between different speed limits, around 20% of the section had a speed limit of 80 km/h. The road was intertwined by short passages through small towns that combined accounted for 20% of the section's duration. Besides the favorable balancing of situational factors, the route was chosen because it correlates with another field study conducted by Volkswagen [95]. This makes it possible to compare the behavior between drivers of the two groups, at least for the rural components of the journeys.

4.2 Stopping maneuver prediction in urban environments

4.1.3 The test group

This field study was designed as a feasibility study for the driver modeling method. A total number of 26 participants collaborated in the study. There were no explicit control variables, as for instance driving experience, sex or age, that guided the selection of subjects. As a result, the test group does not constitute a representative sample of the German population. Some interesting properties of the subjects are presented in table 4.1. As was stated above, no precautions were taken to control any of these

Sex	Age		Driving style	Annual driving (km)		
Male	20	< 25	7 Very sporty	2	< 3000	3
Female	6	< 30	12 Somewhat sporty	9	< 6000	3
		< 40	5 Regular	7	< 12000	7
		> 40	2 Somewhat comfortable	7	< 30000	11
			Very comfortable	1	> 50000	2

Table 4.1: Facts about the field study’s participants

properties. Only the driving style was somewhat evenly distributed between sporty and comfortable drivers. This property has limited validity, however, since it is merely a soft measure judged subjectively through self-assessment by the driver combined with an independent assessment by the test supervisor as part of a questionnaire following the journey.

4.2 Stopping maneuver prediction in urban environments

Using the data from the field study it is possible to model a variety of driving maneuvers. The first maneuver that was used to assess the effectiveness of the method was that of stopping behind a leading vehicle in an urban environment. Those parts of each test drive that were classified by the digital map as belonging to a city area were used as data source. Relevant variables were chosen, fuzzy variables and sample maneuvers extracted from the data and the state machine generated based on the sample maneuvers. After the learning process the resulting state machine was used to predict previously unseen maneuvers to establish the performance of the driver model. Each of the steps is now presented in more detail.

4. EVALUATION OF THE DRIVER MODEL

4.2.1 Fuzzy Variables for stopping maneuver prediction

As was already stated in 3.4, the choice of the optimal variables is a very challenging task. Without a complex feature selection algorithms, the variables have to be chosen by a human expert based on knowledge about the domain. For stopping prediction, the prime variables governing the driver's behavior are those from longitudinal control and data from a range sensor that provides the reason for the stopping maneuver. From those types of data, the following variables were chosen:

- *Velocity (V)*
- *Throttle (T)*
- *Brake Pressure (B)*
- *Time Headway (TH)*

Instead of using throttle or brake pressure, positive and negative acceleration could have been used, since in essence they provide the same type of information. However, it is more difficult for the driver to control the desired amount of acceleration than setting a specific pedal position. As a consequence, the histograms that result from observing pedal positions are more faithful images of the driver's longitudinal behavior than those stemming from acceleration signals. The same argument holds true for choosing Time Headway to represent the personal distance behavior with respect to leading vehicles. Time To Collision, another signal often used to describe that behavior, is dependent on the leading vehicle and is thus more difficult to estimate by the driver. Since the field study was conducted based on regular driving activity there were no activations of either the ABS, ASR or ESC system, and these signals were not considered.

From the data collected in the field study for the above mentioned variables, driver-dependent fuzzy variables can be generated using the method described in 3.3. To illustrate how the variables differ between individuals, three different drivers with differing histograms were chosen for each of the variables. The fuzzy variables for all drivers who participated in the field study can be found in Appendix B.

Figure 4.5 shows the fuzzy variables for velocity of three selected journeys. All histograms were recorded using the first 15 minutes of travel (see 3.3.1) in an urban setting with a speed limit of 50 km/h. Also, in order to reduce effects from traffic

4.2 Stopping maneuver prediction in urban environments

conditions and focus on the driver's speed profile, only samples with no or sufficiently far (a Time Headway of 2 seconds was chosen) leading vehicles were included in the generation of the histograms.

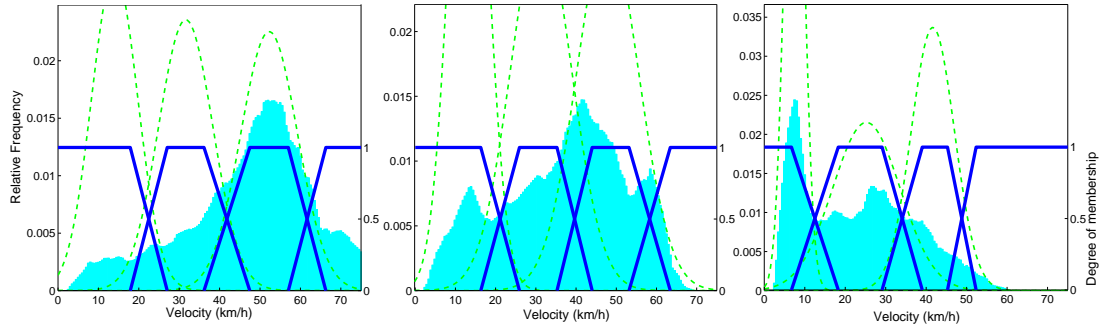

Figure 4.5: Sample fuzzy variables for *Velocity*

The leftmost fuzzy variable represents the typical shape of a speed profile under the conditions mentioned above. A single peak somewhere around 50 km/h with monotonous descending slopes of varying steepness in each direction characterize the distribution. The smoother the slopes, the easier the histogram can be interpreted. The figure in the middle is one example of a histogram that is not quite as explicit. Due to multiple peaks and a broader distribution in general, it is not easy to identify distinctive regions by a GMM. Nevertheless, it is still possible to establish a fuzzy variable that characterizes the subject's speed profile in a suitable way. The rightmost histogram belongs to a subject who drove under very adverse weather conditions. The road was slippery and it snowed heavily, which lead to slow and congested traffic. This explains the unusual peak at low velocities and the lack of data for high velocities. Even though this is certainly not the driver's profile under normal driving conditions, the fuzzy variable is a good representation of his behavior under the influence of bad weather. In this case, a velocity of 40 km/h is actually a high value, which it would not be under normal conditions.

Fig. 4.6 displays the fuzzy partitions for three typical frequency distributions of the driver's activation of the throttle pedal. These histograms were also recorded using the first 15 minutes of city-bound driving. Due to the very high relative frequency of very low pedal positions, only data with values higher than 5 % were considered for the

4. EVALUATION OF THE DRIVER MODEL

histogram. The leftmost fuzzy variable depicts a driver with symmetrical acceleration behavior. This is characterized by the approximately normally distributed histogram with a peak in a relatively low throttle region. The fuzzy variable accounts for this behavior by having a large fuzzy set for *medium Throttle* (the set representing preferred throttle) and comparatively small ones for *low* and *high* throttle positions. The throttle profile in the middle on the other hand resembles a gamma distribution with a single peak in a low throttle region and a long right-sided tail. The interpretation of this type of distribution is that the driver has a low and specific preferred throttle position, but uses much of the vehicle’s acceleration capability to reach the desired speed. The driver-adaptiveness of this fuzzy variable can be seen in that in this case a more specific fuzzy set for the preferred throttle position is generated, followed by a large fuzzy set denoting *high* positions representing the distribution’s tail. A dynamic driver could be responsible for the rightmost histogram. The distribution’s peak is at a larger throttle value than that of the other examples, and the distribution covers almost the entire range of throttle positions. As a consequence, the fuzzy sets for this variable are all shifted to the right to account for the sporty throttle profile.

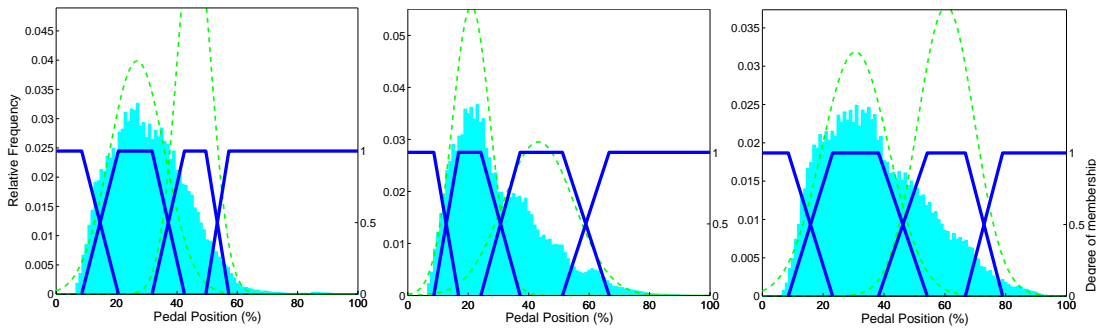

Figure 4.6: Sample fuzzy variables for *Throttle*

The profiles for typical braking behavior are very similar to those of throttle position. The three braking profiles in Fig. 4.7 depict increasing dynamics in usage of the brake pedal. The histograms again represent the first 15 minutes of travel, leaving out data with brake pressure below 5 bar for the same reason as described above. Here again, the higher the sportiness of the driver, the wider the distribution and the closer to high brake pressure the location of the peak. These characteristics of each braking

4.2 Stopping maneuver prediction in urban environments

profile are captured by the positions and shapes of the fuzzy sets.

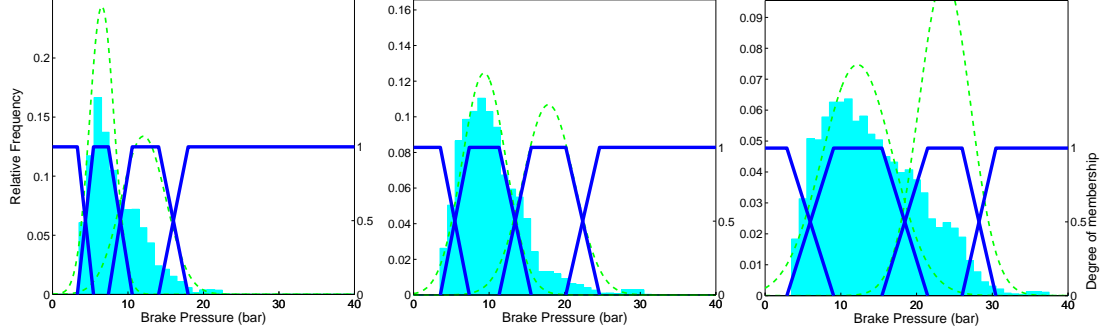

Figure 4.7: Sample fuzzy variables for *Brake Pressure*

In most cases, the histogram for Time Headway can also be approximated by a gamma distribution. One single peak features the driver’s usual headway choice when following a vehicle. The steep slope to the left of the peak contains the situation when the driver’s intention is to overtake or stop closely behind the vehicle, whereas the gently declining slope to the right characterizes how he approaches a slower front vehicle. The first example in Fig. 4.8 is a typical distribution of that kind with a peak at a relatively low Time Headway of approximately one second. The profile in the middle has high resemblance to the first, with the difference that the usual Time Headway is considerably higher. These distributions mark the two extreme profiles when driving under normal driving conditions. In these cases, a fuzzy variable describing *low Time Headway* represents an unusually low distance to a leading vehicle, a *medium Time Headway* the preferred Time Headway when following the vehicle and a *high Time Headway* a high but still relevant range of values. The percentage of data corresponding to a *very high Time Headway* is so low that the driver usually does not include the leading vehicle in his driving behavior. This is the reason why the variable domain does not include values higher than six seconds. The histograms were generated using five minutes of travel with a leading vehicle, which amount to different total driving times for each driver, depending on the traffic situation. Most of the drivers of the field study exhibited histograms with a similar shape to those two, with a peak located between one and two seconds. For some drivers, however, the shape of the histogram were somewhat different, as depicted by the right-handed histogram in Fig. 4.8.

4. EVALUATION OF THE DRIVER MODEL

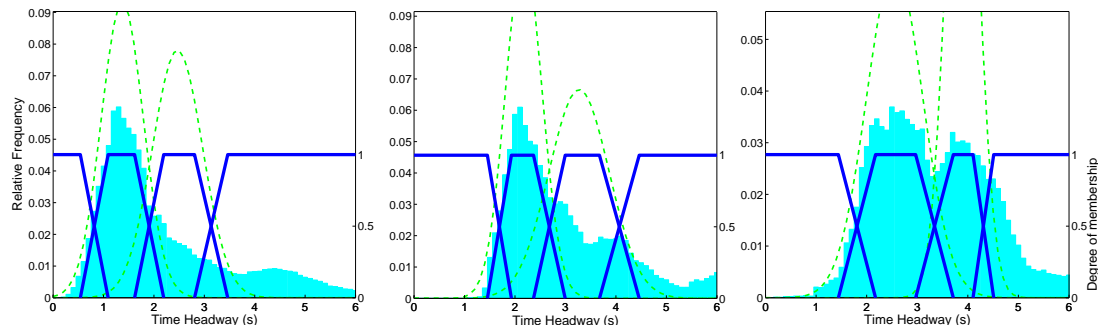

Figure 4.8: Sample fuzzy variables for *Time Headway*

Time plays an important role in the characterization of stopping behavior and driving maneuvers in general. It makes a difference if a driver released the throttle for, say, one second as a reaction to an event in the surrounding, or if he releases it for a longer time in preparation of a stopping maneuver behind a standing vehicle at an intersection. Similarly, the longer the driver has a foot on the brake, the more likely a stopping maneuver becomes. To address this notion, another fuzzy variable, *Duration* (D), is introduced. This variable is linked to a second fuzzy variable, for instance *Throttle*, and stores the duration of the currently active set of that variable. The partition of the fuzzy variable D is depicted in Fig. 4.9. This variable is the same for

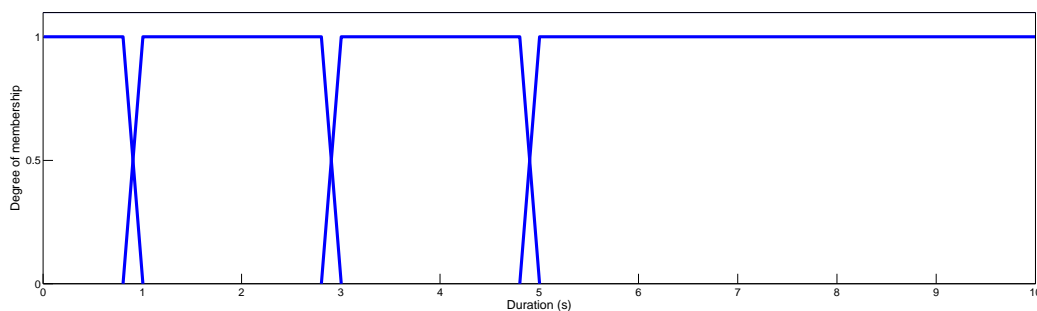

Figure 4.9: Fuzzy variable for *Duration*

all drivers, it does not depend on the individual behavior as all other fuzzy variables do. The partition into fuzzy sets was chosen using knowledge about the duration of individual segments of a driving maneuver, but this need not be the optimal partition.

4.2 Stopping maneuver prediction in urban environments

Other partitions might work just as well or even better, and different partitions for each maneuver being modeled could be of advantage. The fuzzy variable could be constructed in a driver-adaptive way by generating histograms for the duration of the dependent fuzzy variable. A data point in this case would be the length of time the variable has remained approximately the same, and the counter restarted each time the value of the underlying signal changes substantially. For instance, if a driver brakes softly for 1.2 seconds before braking more strongly or releasing the brake, this value would be added to the histogram. Based on the histogram, a fuzzy set for duration could be generated using the method described in section 3.3. This has not been attempted in this thesis, however, and remains an option for further research.

The more variables are used in a model, the more specific a rule becomes to the examples used in the training process, thereby restricting its chances of identifying new maneuvers. This phenomenon does not only apply to the rulebase, but also to the rule sequence a maneuver consists of. The more variables a state consists of, the more often the states will change due to changes in active fuzzy sets. Since in the current implementation of the state machine an observed sequence needs to be identical to a sequence from a learning sample, quickly changing states reduce the likelihood of encountering that exact same sequence during the prediction stage. Also, splitting a maneuver into subparts is only useful if the transitions between them have a semantic meaning for the maneuver, meaning that it is possible to infer how the driver actually conducted the maneuver from looking at the sequence. The more the states of a sequence change, the harder it is to find meaning behind each of the transitions. This in turn restricts the interpretability of the model.

Since for the current maneuver the fuzzy variable *Duration* is most relevant for the variables *Brake Pressure* and *Throttle*, only these two were added to the driver model. Together with the four variables listed above, the driver model contained of six fuzzy variables. To reduce the effects discussed above, and since the duration of throttle and brake positions are independent from each other, two driver models, each containing one of the *Duration* variables, were chosen. In addition, a third rulebase containing only the four driver-dependent fuzzy variables was added to the model to avoid any negative effect the duration of a variable might have on the performance of the model. For each step, the rulebases were evaluated independently and the highest

4. EVALUATION OF THE DRIVER MODEL

Rulebase 1	Rulebase 2	Rulebase 3
<i>Velocity</i>	<i>Velocity</i>	<i>Velocity</i>
<i>Brake Pressure</i>	<i>Brake Pressure</i>	<i>Brake Pressure</i>
<i>Throttle</i>	<i>Throttle</i>	<i>Throttle</i>
<i>Time Headway</i>	<i>Duration Throttle</i>	<i>Duration Brake</i>
	<i>Time Headway</i>	<i>Time Headway</i>

Table 4.2: Fuzzy variables used for stopping maneuver prediction

value selected as the prediction value of the model. The variables for each of the three rulebases are listed in table 4.2.

4.2.2 Sample maneuvers for stopping maneuver prediction

As was stated in section 3.4, sample maneuvers need to be extracted from the data to generate the models. Fig. 3.19 already showed an example for a stopping maneuver extracted from the field study. How stopping maneuvers in urban environments are extracted from driving data is described in more detailed here.

As a first step, situations where the vehicle's velocity dropped beneath a certain threshold were identified. A threshold of 10 km/h was chosen, because it is difficult and not reasonable to distinguish between situations where the vehicle comes to a full stop and those where the driver accelerates again after reaching that threshold. After these situations were identified, the starting and stopping points had to be chosen for the learning process. The stopping condition is the point of lowest velocity within a contiguous region of velocity lower than 10 km/h. Finding a suitable starting condition is more complicated. There are for instance abrupt stopping maneuvers that take only a few seconds and those where the driver releases the throttle and brakes gently long before reaching the leading vehicle and stopping behind it. Consequently, it is not reasonable to just take a fixed time difference before the stopping condition as starting time for the example. Instead, the first time step where a stopping intention is actually observable was chosen. Such a condition arises when the driver releases the throttle and does not push it beyond a certain threshold afterwards. A threshold of 15% was chosen, because for all drivers who participated in the study this was approximately the point where the fuzzy sets for *low* and *medium* throttle positions overlapped. Throttle positions below that threshold have very little effect on the vehicle's speed and hence

4.2 Stopping maneuver prediction in urban environments

do not necessarily convey a desire by the driver to accelerate. Fig. 4.10 shows one such example where the driver releases the throttle and later on presses it just a small amount with no visible effect. Hence, the starting time for the learning method is after the first release of the throttle pedal.

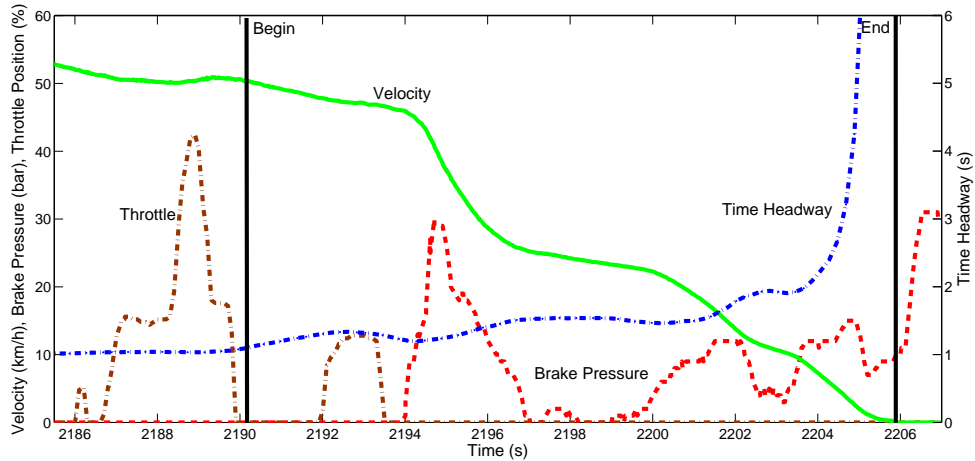

Figure 4.10: Sample stopping maneuver

There were also cases where the driver kept the throttle position below the above mentioned 15% for a very long time, for instance 20 seconds, before braking and coming to a halt. However, it cannot be assumed that the driver planned the stopping maneuver so long in advance. In those cases, the starting point for the stopping maneuver was set to 5 seconds before the driver started braking. The choice of 5 seconds is rather arbitrary, since it is not possible to identify the driver's intention without any activity from his side. The exact value is not essential, however, since given the belief calculation defined in Eq. 3.19 all rules that were identified within those 5 seconds that do not characterize the maneuver appropriately receive low belief values.

Depending on traffic conditions, each driver had a different number of stopping maneuvers. As a matter of fact, this difference was quite substantial, the number of maneuvers ranging from 7 to 23 stopping maneuvers. How often a stopping maneuver occurred for each of the drivers is summarized in table 4.3.

4. EVALUATION OF THE DRIVER MODEL

ID	1	2	3	4	5	6	7	8	9	10	11	12	13
# maneuvers	11	15	19	13	23	19	9	12	19	16	23	19	19
ID	14	15	16	17	18	19	20	21	22	23	24	25	26
# maneuvers	12	16	13	14	10	14	9	13	17	18	9	7	11

Table 4.3: Number of stopping maneuvers in the field study

4.2.3 Evaluation of the stopping maneuver prediction

Once the variables and sample maneuvers have been identified, the fuzzy rulebases and state machines can be constructed from the available data as described in sections 3.4 and 3.5. The resulting state machines are used to predict previously unseen driving maneuvers. How well a driver model is able to predict new maneuvers determines its performance. If a model is able to correctly predict all maneuvers that were used to train it but no or only few new samples, its performance is poor, even though it did predict the training data. Only if the training data contains the complete set of possible samples, classifying all training samples correctly is enough to provide an optimal performance. In the domain of predicting driving behavior in real environments it is not feasible to generate all possible training samples to be used for training. As a consequence, it is necessary to judge how well the model performs on previously unseen data, i.e. how well it is able to generalize from the data used for training.

Correctly predicting new maneuvers is not the only performance factor of a driver model. A model that overgeneralizes also has a negative performance. In this case, the driver model predicts a respective maneuver even if the driver is doing something unrelated. Such a model can be very good at predicting a maneuver, but if it classifies many different situations as belonging to the target class, then it is of limited practical value. Usually there is a trade-off between the number of correctly predicted new maneuvers (the prediction rate) and the amount of data not belonging to the type of maneuver erroneously classified as a such (the false-alarm rate). It is often possible in machine learning methods to adjust parameters that have an effect on this trade-off. Increasing the prediction rate usually also increases the false-alarm rate, whereas reducing the false-alarm rate also decreases the prediction rate. One example is the parameter β used in Eq. 3.19 to calculate the belief value of a rule. Which of the two

4.2 Stopping maneuver prediction in urban environments

rates is more important depends largely on the application domain and is discussed further in the context of this thesis in 5.3.2.

One of the most common methods in machine learning to calculate prediction and false-alarm rates is to split the available labeled data into training and test sets. The training set is used to learn the model, which is then evaluated using the test set. This method requires a relatively high number of positive and negative samples, generally at least in the hundreds, to allow for the separation into two sufficiently large sets. Unfortunately, there are not enough sample stopping maneuvers in the field study for this method. Driver 25 for instance only has 7 positive samples, splitting these into reasonable training and test sets is not possible.

If only few samples are available, a second method called Leave-One-Out cross-validation can be used to assess the performance of a machine learning model. In this method the available data is split into N sets, where N is the total number of samples. Each of the sets contains all training samples except for one. The algorithm is run N times, using the $N - 1$ samples to learn the model and the remaining one to test the performance of the model in that configuration. Once all experiments have been conducted, the number of correctly predicted maneuvers divided by N is the prediction rate. To calculate the false-alarm rate, all relevant driving data, in this case the parts of the trip that took place in an urban setting, is split into two sequences. Three quarters are used as negative samples for the calculation of the belief values, and one fourth to establish the false-alarm rate. The division can be defined by using the sample positive maneuver as reference and placing the boundaries of the negative sequence around that reference interval. This is necessary to make sure that both prediction and false-alarm rates are based on previously unseen data. The false-alarm rate is calculated as $fa = \frac{f_p}{f_p + t_p}$, where f_p is the sum of all data points in the negative sequence predicted as maneuver and t_p is the number of data points in the corresponding positive sample that were predicted correctly. A data point d_i is classified as belonging to the maneuver, if the prediction value is greater than the threshold $P(d_i) > 0.8$. In order to exclude outliers, a maneuver is only classified as such if three consecutive data samples exceed the above threshold. A good way to visualize the results is through a receiver operator characteristic (ROC) diagram as shown in Fig. 4.11. For each driver of the study, the prediction and false-alarm rates are displayed as one point in the diagram.

4. EVALUATION OF THE DRIVER MODEL

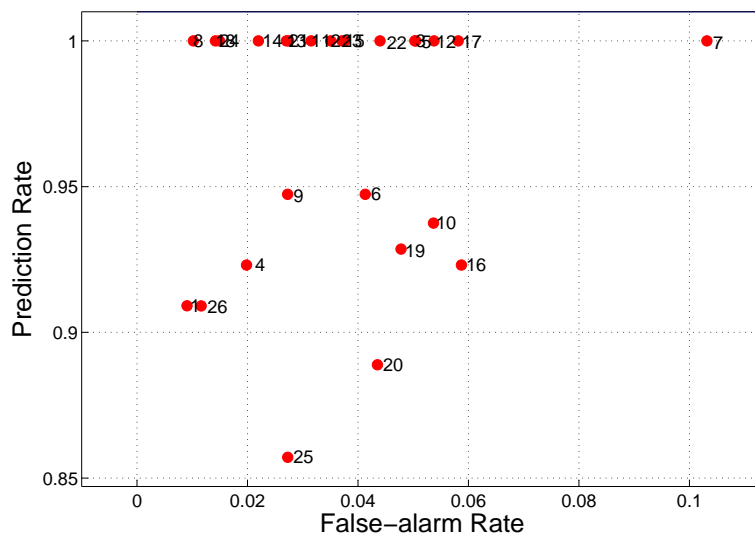

Figure 4.11: Cross-validation results for stopping maneuver prediction models in the field study

The diagram shows that the driver models are able to predict all maneuvers for 16 of the 26 drivers, failing to correctly predict one maneuver for each of the remaining drivers. These incorrect predictions are due to stopping behavior that differed substantially from that observed in the training samples. The results indicate that the subjects generally did exhibit consistent behavior that can be predicted successfully by a driver model. It is to be expected that as driving time and number of training samples increase, the method presented in this thesis will be able to successfully predict every regular stopping maneuver. The results also show that the driver models exhibit a very low false-alarm rate. With the exception of driver 7, all drivers had a mean false-alarm rate lower than 6 %. One of the main situations where false-alarms can occur is the case when the driver slows down behind a leading vehicle but accelerates again after the leading vehicle accelerates, thus never reaching the threshold velocity of 10 km/h. Discriminating between the two situations, the one described here and when the vehicle stops, is very difficult given the input variables. But, as the results show, the driver models are able to predict the behavior correctly most of the times.

A second interesting piece of information illustrating the performance of a driver model is the prediction time t_p . A driver model that predicts a driving maneuver shortly

4.2 Stopping maneuver prediction in urban environments

ID	1	2	3	4	5	6	7	8	9	10	11	12	13
\bar{t}_p	6.3	7.1	6.2	7.0	6.8	10.6	7.3	5.3	4.5	4.6	7.1	5.2	7.1
δ_{t_p}	2.5	2.2	3.7	4.6	3.9	4.7	3.6	2.7	2.3	1.6	4.6	2.5	5.1
ID	1	2	3	4	5	6	7	8	9	10	11	12	13
\bar{t}_p	6.1	7.3	5.7	6.9	5.2	8.7	6.9	5.6	6.4	6.7	5.1	6.3	5.7
δ_{t_p}	2.6	3.7	2.4	2.3	3.3	4.1	4.0	2.6	3.4	3.0	3.0	2.2	2.9

Table 4.4: Mean and standard deviation of prediction times

before the maneuver ends is more of a recognition than a prediction model. In the context of the adaptation of an ADAS, recognizing a maneuver is not useful, since most of these systems assist the driver before or during the execution of a maneuver, thus requiring a prediction model. For stopping maneuver prediction, the prediction time is the time between the first time the stopping maneuver was predicted, $P(d_i) > 0.8$, and the stopping point of the sample maneuver. The longer that time becomes, the earlier the model is able to predict a maneuver and hence the better the model’s performance is. For those instances where a driver model of the Leave-One-Out cross-validation successfully predicted the stopping maneuver, the detection time was calculated. Table 4.4 shows the mean (\bar{t}_p) and standard deviation (δ_{t_p}) of the detection times from the cross-validation experiment. The mean prediction time across all subjects is 6.45 seconds. The driver models are able to predict a stopping maneuver on average more than six seconds before the maneuver is terminated. This is generally more than enough time for the purpose of adapting an ADAS.

4.2.4 Analysis of the stopping maneuver prediction model

If a driver model is to be included in a commercial vehicle, the model’s transparency is of utmost importance. It is not acceptable to use methods where, like with most types of neural networks, it is difficult or even impossible to explain why the model operates the way it does. This is one of the advantages of fuzzy logic, where the internal structure of the model can be explained by inspecting its rules. Such a model can also become very hard to analyze, however, if a large number of variables and/or sets for the variables are used, resulting in huge and complex rulebases. A complex rulebase can be very difficult to interpret and needs to be avoided.

4. EVALUATION OF THE DRIVER MODEL

The rules that constitute the driver models developed in this section are simple enough to be interpretable. They consist of just up to five variables, making it possible to understand the concept behind each rule and the interaction between the rules. Nevertheless, as was mentioned earlier, the number of rules grows exponentially with the number of variables, so each variable adds significantly to the total number of rules. A large rulebase is negative for at least two reasons. It limits the interpretability and, at least as important, increases the runtime of the algorithm, since the rule with the highest belief needs to be calculated in each step from among all available rules. For the model in the current context, each of the variables has four sets, adding up to rulebases with up to $4^5 = 1024$ rules. Even though this is a comparatively small rulebase, it is still too large a number to be easily evaluated through inspection.

Most of these rules do never appear in any of the maneuvers that the model is designed to predict. Since the rulebase is generated from examples, only those rules that do appear in one of the examples are included in the rulebase. This reduces the size of the rulebase substantially. A further reduction of the size of a rulebase can be achieved by removing those with poor belief, as was mentioned in section 3.4.4. The mean sizes and their standard deviations of the rulebases generated by the driver models resulting from the cross-validation procedure are shown in table 4.5. As can be expected, the rulebase with only four variables has a lower number of rules than the other two. Even though these can have up to 1024 rules, only up to around 80 of them are relevant for the prediction of stopping maneuvers. These are very compact rulebases that can easily be analyzed by a human being. Restricting the rulebase to those rules with a belief value $B(r_i) > 0.5$, which, given that the chosen value for β favors precision, selects those rules that appeared at least as often in positive as in negative data samples, again reduces the number of rules to approximately 25 rules. The differences in size between the models from individual experiments of the cross-validation procedure are very small, they do not deviate from one another by more than a standard deviation of 2.5 rules. This suggests that the complexity of stopping maneuvers, if measured in number of rules, generally does not differ significantly. It would be interesting to study if there is a common core, or number of cores, of state sequences among maneuvers of the same or even between different drivers. This core could provide a general representation of common instances of a type of maneuver.

4.2 Stopping maneuver prediction in urban environments

ID	Rb 1		Rb 2		Rb 3		ID	Rb 1		Rb 2		Rb 3	
1	27.9	1.4	62.2	2.4	63.2	2.9	14	26.3	0.7	58.6	1.6	63.5	1.9
2	22.7	0.5	54.4	1.5	52.0	1.1	15	19.8	0.5	50.8	1.6	50.3	1.0
3	32.3	1.1	70.3	1.7	72.4	1.8	16	28.4	1.1	65.0	2.3	61.4	2.0
4	26.5	0.6	69.9	1.8	67.2	2.1	17	29.0	1.8	66.2	3.5	63.6	3.5
5	28.7	0.7	79.0	1.3	70.9	1.4	18	21.8	0.4	54.4	1.3	52.2	1.3
6	24.7	0.4	68.6	1.5	62.0	1.3	19	31.0	1.3	78.7	2.2	66.9	1.8
7	26.5	1.7	53.8	3.1	50.0	2.1	20	20.8	1.3	44.1	2.8	46.1	2.3
8	30.0	1.7	62.2	2.9	53.7	3.3	21	26.3	1.3	66.3	2.5	66.7	3.2
9	30.3	1.0	72.8	2.4	64.3	2.5	22	29.5	1.6	74.7	3.3	60.6	1.9
10	24.6	0.6	64.3	1.7	56.8	1.1	23	26.7	0.7	65.3	2.1	65.6	2.0
11	26.6	0.7	67.8	1.5	63.2	1.3	24	26.8	0.9	62.0	2.6	59.3	3.3
12	34.5	0.8	86.7	2.4	76.6	1.9	25	25.1	1.6	49.7	3.4	48.1	2.6
13	27.7	0.7	67.6	1.7	70.7	1.7	26	31.0	1.6	72.1	2.6	63.0	2.7

Table 4.5: Mean size and its standard deviation of rulebases for stopping maneuver prediction

For the evaluation of the method it is important to analyze the three requirements real-time capability, use of resources and traceability mentioned in section 3.1. Predicting a driving maneuver involves the calculation of the prediction value involves identifying the rule with the highest effectiveness and the corresponding belief value of the current sequence of rules. Performing these operations with such small rulebases and hence state machines can be done in real-time. The amount of storage space required for the model is also very low given the small size of the models. This is not true, however, for the generation of the fuzzy variables explained in section 3.3, specifically the computation of the earth movers distance during the computation of the histogram and its subsequent approximation by a GMM. Fortunately, both tasks do not need to be performed in real-time, since they are part of the process generating the driver model. For the purpose of this thesis, these calculations should ideally take not more than a couple of minutes, which should be possible with good implementations of the algorithms. There exist efficient implementations for both algorithms, for instance EMD¹ in the case of the earth movers distance.

¹<http://www.cs.duke.edu/~tomasi/software/emd.htm>

4. EVALUATION OF THE DRIVER MODEL

ID	Rb 1	Rb 2	Rb 3	ID	Rb 1	Rb 2	Rb 3
1	6.5 0.7	20.4 1.6	18.8 1.6	14	8.5 0.7	18.9 1.3	27.3 1.4
2	4.9 0.2	17.6 0.6	18.4 0.8	15	5.0 0	14.5 0.8	19.1 1.0
3	8.7 0.6	27.7 1.0	27.7 1.0	16	10.2 0.8	24.8 1.8	26.0 1.4
4	5.7 0.4	20.2 1.3	24.0 1.1	17	8.5 0.9	25.4 2.1	28.2 2.1
5	11.3 0.7	34.6 1.2	31.8 1.2	18	3.8 0.4	19.5 1.0	19.4 0.9
6	7.4 0.6	24.1 1.0	23.0 1.3	19	11.2 1.1	30.1 2.0	27.4 1.8
7	8.4 0.8	23.7 1.8	17.7 1.6	20	7.4 0.5	17.3 1.8	20.8 1.7
8	7.7 0.4	19.1 1.1	16.3 0.9	21	8.3 0.9	26.7 1.4	28.5 2.5
9	9.5 0.7	24.0 1.5	26.5 1.5	22	10.8 1.0	31.4 2.5	27.6 1.8
10	5.0 0	19.2 1.1	19.5 1.3	23	8.7 0.4	24.5 1.1	25.6 1.2
11	7.6 0.6	21.0 1.2	26.3 1.1	24	7.5 0.7	18.6 1.5	18.7 1.9
12	12.5 0.7	30.7 1.5	31.8 1.1	25	4.7 0.9	15.8 1.9	11.1 1.2
13	7.6 0.4	18.1 0.5	24.1 1.1	26	7.8 0.4	27.6 1.9	21.0 0.8

Table 4.6: Mean size and standard deviation of rulebases containing rules of high belief for stopping maneuver prediction

Since there are only relatively few rules in any of the rulebases, each state machine can be visualized and the driver's behavior inferred from the graph. To illustrate this, a sample state machine is visualized using the graph visualization tool GraphViz¹. The state machine was generated using one of the driver models from driver 24 and all rules, even those with low belief, from Rulebase 1. The visualized state machine is depicted in Fig. 4.12. The nodes represent single states (rules) of the state machine. The numbers in each of the nodes represent the sets for each of the fuzzy variables in the configuration. The variables in this case are, from left to right and top down, *Velocity*, *Brake Pressure*, *Throttle* and *Time Headway*. The thicker the circle, the higher the belief of the rule and hence the better the rule characterizes a stopping maneuver. In most of the nodes with a high belief, the *Velocity* of the vehicle was *slow*, the driver braking and the leading vehicle not too far, which are strong indications of a stopping maneuver. One interesting distinction is that between nodes (1 2 1 4) and (1 3 1 4) at the right end of the graph. Even though both nodes are very similar, they have very different belief values. This is to be expected, because the first node represents

¹<http://www.graphviz.org>

4.2 Stopping maneuver prediction in urban environments

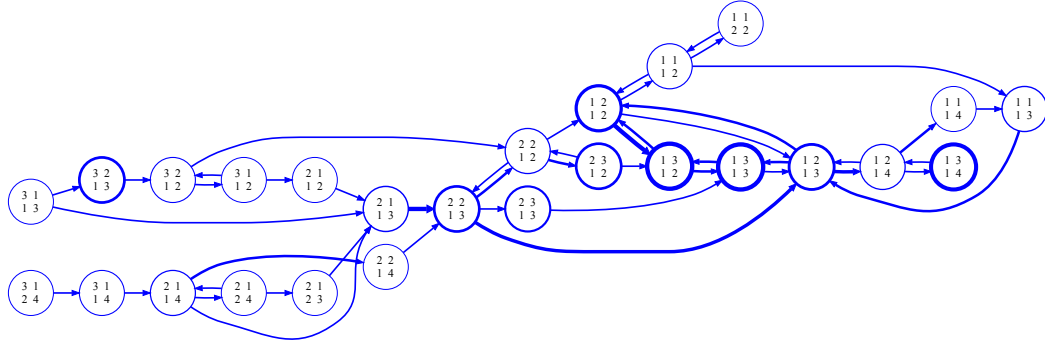

Figure 4.12: Sample state machine for stopping maneuver prediction

a soft braking behavior with a distant leading vehicle, which must not necessarily be a stopping maneuver, whereas for the second node the driver brakes rather strongly, which in turn does suggest a stopping maneuver, even if the leading vehicle is far away. This is one example for how graphs such as this one can be used to extract information about the driver's behavior.

The edges represent the transitions between nodes found in stopping maneuvers. It is not easy to display the sequences for single maneuvers (see 3.5.2) from the graph structure without losing its simplicity. How many maneuvers did follow a transition is modeled as the different thickness values of the edges. The thicker the edge, the more maneuvers had that transition in their rule sequences. From that information the common sequences describing typical maneuvers can be extracted, provided such typical maneuvers exist. One important transition for this driver is that from node (2 1 1 3) to (2 2 1 3). Most maneuvers follow this transition, meaning that the driver usually starts braking when his *Velocity* is *medium* and the *Time Headway* to the leading vehicle *high*.

There are two main types of behaviors that can be inferred from the graph. Either the vehicle is following a moving leading vehicle, the sequences starting at node (3 1 1 3), or is approaching a standing or slowly moving vehicle, the sequence beginning at (3 1 2 4). This can be inferred from the different sets for *Time Headway* found in the different sequences. Since the transitions leaving both these nodes are not thick, most sample maneuvers do not start at exactly those nodes, but at other nodes along

4. EVALUATION OF THE DRIVER MODEL

the sequences. Regardless of the initial situation, many maneuvers pass through the node (2 2 1 3), which symbolizes the point of braking that will eventually lead to the standstill, illustrated by GraphViz' layout engine placing it in the center of the graph. The approximate half of the graph at the right of that node models how the driver employs the brake after that initial brake, depending on his velocity and the distance of the leading vehicle. Here again the graph indicates roughly two types of scenarios. In one scenario the leading vehicle comes closer to the vehicle even if the driver is braking, which suggests that the leading vehicle also brakes due to an external event. In this case the driver brakes more strongly to increase the distance again. In the other the *Time Headway* remains the same or increases due to the braking, in which case the driver keeps braking with unchanged low intensity.

Evidently, the graph can be analyzed further to reveal additional and more complex behavior patterns. The aim here was to show that it is possible to inspect the driver models that are generated by the learning process, proving the traceability of the driver modeling method developed in this thesis. The above description of the graph resembles the textual description of a sample stopping maneuver in section 3.1 that was used to motivate the development of the method. This shows that the driver modeling method described here does approximate the way human beings execute driving maneuvers.

4.3 Turning maneuver prediction in urban environments

The second maneuver that was chosen for the evaluation of the driver modeling method were left-turn maneuvers in urban environments. The proceeding is similar to that from section 4.2, with the difference that the analysis concentrates on the evaluation of the models' performance and the size of the respective rulebases.

4.3.1 Fuzzy Variables for turning maneuver prediction

For left-turn maneuvers, a different set of variables was chosen. Besides from the longitudinal fuzzy variables, variables describing the lateral behavior of the driver were included in the model. The variables are

- *Velocity* (V)
- *Throttle* (T)

4.3 Turning maneuver prediction in urban environments

- *Brake Pressure (B)*
- *Distance To Intersection (DI)*
- *Yaw Rate (Y)*
- *Left Indicator (LI)*

From the three new variables, only *Yaw Rate* is a driver-adaptive fuzzy variable, describing the driver's lateral behavior. This was chosen over other possible signals such as lateral acceleration or steering angle. The steering angle is arguably a better signal to model a fuzzy variable after, since it is the steering wheel that the driver operates to produce lateral movement. But the better resolution of the yaw rate made it possible to identify more subtle changes in lateral movement than if the steering wheel had been used, which led to the decision of including it in the model.

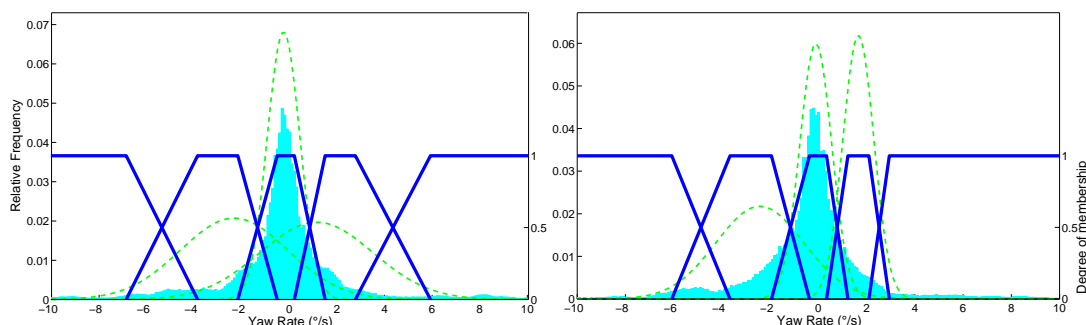

Figure 4.13: Sample fuzzy variables for yaw rate

The two variables in Fig. 4.13 represent the two typical types of partitions found in the field study. The histograms again represent the first 15 minutes of travel in urban environments. The left fuzzy variable belongs to a driver who uses approximately the same yaw rate values in lateral maneuvers, regardless of direction, which can be inferred from the second and fourth Gaussian distributions. Most drivers have a fuzzy variable of this symmetrical kind, varying only in the location and size of the aforementioned Gaussians. The second type of drivers use considerably lower yaw rate when driving to the right than when lateral movement to the left is needed. This can again be observed by comparing the second and fourth fuzzy sets. The reason for this behavior might be

4. EVALUATION OF THE DRIVER MODEL

that in Germany the driver's seat is on the left side of the vehicle, providing a better visibility on that side. This in turn leads the driver to execute stronger maneuvers involving lateral movement to the left. It could also be a bias in the chosen driving route towards narrower curves and intersections to the left than to the right. This is not probable, because most drivers do not display this left-sided bias.

The purpose of the variable *Distance To Intersection* is to provide information about the distance to the next segment. Clearly it is only possible to turn if a new segment, in this case a junction, is close enough to the current position of the vehicle. The information about this distance is provided by the digital map in the test vehicle. In the version provided by NAVTEQ a new segment begins whenever something on the road changes, for instance a new curvature, an intersection or a zebra crossing. In the case of intersections, the new segment begins at the center of the intersection. Unfortunately, since intersections can have very different shapes, it is not possible to say with certainty at which distance to the new segment the road the driver wants to turn into crosses the street the vehicle is currently on. Therefore, a fuzzy set denoting a low distance to the joining road needs to include relatively high values. Based on the analysis of the distances reported by the digital map for intersections that were part of the driving route, the fuzzy partitioning in Fig. 4.14 was defined. In most cases, the turning maneuver took place with a distance lower than 25 meters, with some exceptions involving big intersections where the turning maneuver took place at even higher distances. This is not a driver-dependent variable, since the distance to an intersection is not a value the driver can control.

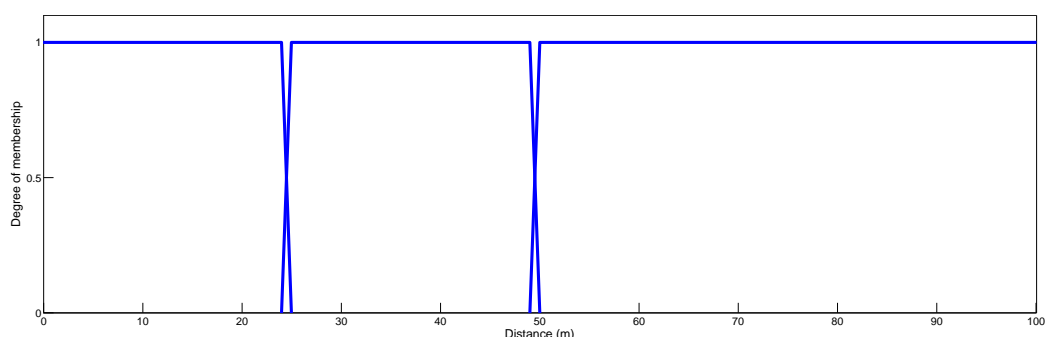

Figure 4.14: Fuzzy variable for distance to intersection

4.3 Turning maneuver prediction in urban environments

Rulebase 1	Rulebase 2
<i>Velocity</i>	<i>Velocity</i>
<i>Brake Pressure</i>	<i>Brake Pressure</i>
<i>Throttle</i>	<i>Throttle</i>
<i>Yaw Rate</i>	<i>Yaw Rate</i>
<i>Distance To Intersection</i>	<i>Distance To Intersection</i>
	<i>Left Indicator</i>

Table 4.7: Fuzzy variables used for turning maneuver prediction

Yet another relevant variable for turning maneuver prediction is the *Left Indicator* variable. In the case of left-turn maneuvers the activation of the left indicator is a strong indication of the driver’s desire to turn in that direction. This signal is not fuzzy, since it is a binary signal. The fuzzy variable modeling the indicator signal consists of the two singleton fuzzy sets in Fig. 4.15.

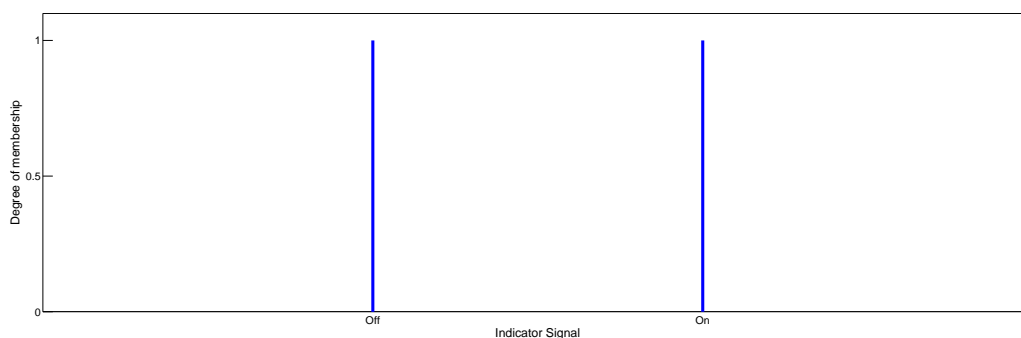

Figure 4.15: Fuzzy variable for left indicator

As with the prediction models presented in the previous section, more than one configuration of fuzzy variables is recommendable to improve the model’s performance. The two configurations are shown in table 4.7. The reason in this case is the indicator signal. Not all drivers used the indicator consistently to suggest a turning maneuver. Always including the Left Indicator is not recommendable. If for instance a driver did not use the signal in exactly one of his maneuvers, then the respective instance of the Leave-One-Out cross-validation run with that example as test case will not be able to recognize it correctly, because all examples used for learning contained the indicator

4. EVALUATION OF THE DRIVER MODEL

signal. Using at least one configuration (in this case Rulebase 1) without the indicator signal increases the likelihood of correctly classifying the test case. The likelihood is also increased if more than one sample maneuver was executed without the use of the indicator, since the data from all samples are used to calculate the belief of the model's rules, not only those where the indicator was not used.

4.3.2 Sample maneuvers for turning maneuver prediction

Identifying turning maneuvers is not an easy task. The simplest approach is to examine signals like yaw rate or steering angle to find patterns usually found in those kinds of maneuvers. It is not always possible to distinguish between steering behavior found in turning and curve-following situations. Combining the steering signal with the respective indicator signal yields a much better distinction between the two types of situations and allows for reasonably accurate identification of turning sequences. However, not every driver does use the indicator signal consistently, which might lead to the omission of valid turning maneuvers and as a result influence the performance of the driver model in a negative way. This makes it necessary to include information from a digital map in the maneuver extraction process. Most modern navigation systems contain an electronic horizon, which provides information about the distance to the next road branching off. Only the signals described in 4.1.1 were extracted from the digital map, which did not include the electronic horizon. Merely the distance to the next segment, which need not be a junction and with the precision described in 4.3.1, could have been used to infer the presence of a road the driver could turn into. Unfortunately, the data was not precise enough to provide a reasonable extraction of turning maneuvers.

Therefore, a different approach was used to identify the turning maneuvers. Since all participants drove a predefined route, it is possible to locate all left-turn maneuvers of that driving route. The GPS positions of these regions were collected and compared to the GPS positions from the vehicle's GPS system. The end of the steering pattern within the time window marked by the matching GPS positions typically found in turning maneuvers marked the end of the sample maneuver. Where a turning maneuver begins cannot be said with absolute certainty. In most cases, setting the turn signal is an indication that the driver wants to turn and is an obvious candidate for a starting point. This need not be the case, it is possible that the driver needs to react to

4.3 Turning maneuver prediction in urban environments

his environment and hence performs a different maneuver, even if the turn signal is activated. Therefore, setting the turn signal is only used as a starting point for the example if it does not take too long (more than 10 seconds) for the driver to actually start turning. Otherwise only the last 10 seconds before steering are used as training data. If no turn signal was used, 5 seconds were added before the begin of the steering pattern to mark the begin of the sample. These are again rather arbitrary values, but, as argued before, the rule compression process removes those rules within that time frame not specifically describing a turning maneuver from the rulebase. A typical left-turn maneuver is shown in Fig. 4.16. In future research, this manual maneuver extraction will be replaced by an automated procedure using more detailed information from the navigation system. The regular driving route contained 19 left turns. One

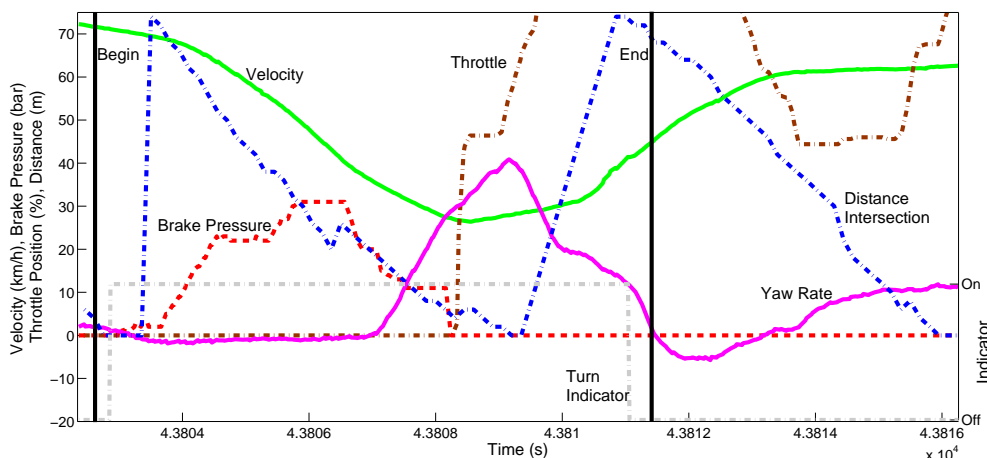

Figure 4.16: Sample left-turn maneuver

irregularity was that for 6 drivers a small detour had to be made, reducing the number of turns to 16. Other drivers had small variations in the route at the beginning or the end of the journey, resulting in a slightly different number of left turns. The number of maneuvers for each individual driver is shown in table 4.8.

4.3.3 Evaluation of the turning maneuver prediction

Using the examples extracted above, the Leave-One-Out cross-validation procedure was run on the data. The results are displayed in Fig. 4.17. For a little more than half

4. EVALUATION OF THE DRIVER MODEL

ID	1	2	3	4	5	6	7	8	9	10	11	12	13
# maneuvers	18	19	15	19	19	16	16	19	19	19	17	19	19
ID	14	15	16	17	18	19	20	21	22	23	24	25	26
# maneuvers	18	17	19	19	19	17	19	19	17	17	17	19	19

Table 4.8: Number of turning maneuvers in the field study

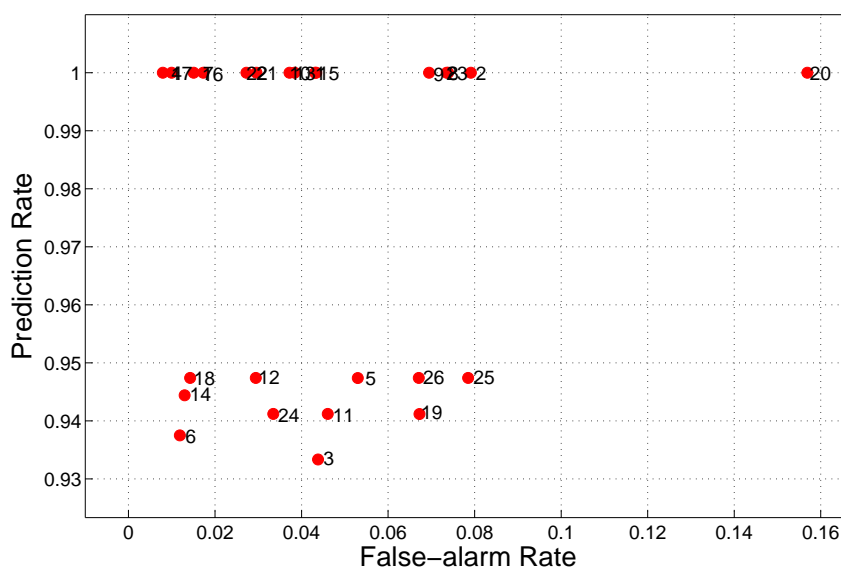

Figure 4.17: Cross-validation results for turning maneuver prediction models in the field study

the subjects, all maneuvers were predicted correctly. In all other cases, one of the maneuvers was not. Those incorrect predictions had one main reason. There was one T-junction in the route where the left turn had the right of way and the street joining the main route was rather small. It can be argued whether such a situation is a left-turn maneuver at all. Consequently, many drivers did not use the turn signal or reduce the velocity significantly in that particular maneuver. For some of those drivers the rules and rule sequences of the driver model did never reach the prediction threshold of 0.8 during the left-turn. For those drivers, that maneuver differed too much from the samples used for learning, for instance through a lack of braking or an unusually high velocity. In essence, that maneuver is a different maneuver than regular left-turn

4.3 Turning maneuver prediction in urban environments

maneuvers and could also be treated as a completely different type of maneuver. This example shows the difficulty of defining a maneuver, which was already discussed in section 2.1.

The driver models also exhibit a low false-alarm rate, with the exception of driver 20. The false-alarm rate tends to be a little higher than that found for the driver models from the previous section. This is mainly due to the high similarity between this type of maneuver and that of a left lane-change, another very common type of maneuver. It is to be expected that more detailed data from a digital map regarding the distance to an intersection or the incorporation of data from a range sensor as motivation for a left lane-change might produce an even lower false-alarm rate.

4.3.4 Analysis of the turning maneuver prediction model

For the prediction of left turn maneuvers, tables 4.9 and 4.10 depict the mean sizes and their standard deviations of the rulebases generated by the driver models. When

ID	Rb 1		Rb 2		ID	Rb 1		Rb 2		ID	Rb 1		Rb 2	
1	67.3	2.8	88.2	4.1	10	74.5	2.0	102.3	2.7	19	64.7	1.7	90.0	3.7
2	46.2	1.7	66.6	2.1	11	54.0	1.4	78.4	1.9	20	79.9	2.8	104.4	3.7
3	58.2	2.0	77.5	2.8	12	60.8	1.2	90.4	2.3	21	79.2	2.5	109.9	3.3
4	57.9	1.7	82.9	2.5	13	59.5	3.1	84.4	5.0	22	66.5	2.3	94.3	2.8
5	84.1	2.7	122.2	4.0	14	63.7	1.3	82.8	2.1	23	76.3	1.8	103.7	3.2
6	67.0	3.4	98.7	4.6	15	58.2	2.5	73.3	2.9	24	61.0	3.4	71.8	3.5
7	54.7	1.5	60.5	1.6	16	68.5	1.9	95.0	2.9	25	76.3	2.0	104.2	3.1
8	50.9	2.4	73.8	3.2	17	65.7	1.7	89.4	2.8	26	69.0	1.4	102.7	2.0
9	77.0	2.1	99.9	2.4	18	73.3	1.9	93.3	2.7					

Table 4.9: Mean size and standard deviation of rulebases for left-turn maneuver prediction

comparing the results to those obtained by the stopping maneuver prediction models in section 4.2.4, some similarities are revealed. In both cases, the number of rules for the configurations with five variables (Rb 2 and 3 in the previous example, Rb 1 in this) are comparable in size, which can be expected given the similar number of fuzzy sets in each variable and the rather similar sequence of behavior needed for the two maneuver types. The importance of the variables *Duration* and *Left Indicator* for both maneuvers

4. EVALUATION OF THE DRIVER MODEL

ID	Rb 1	Rb 2	ID	Rb 1	Rb 2	ID	Rb 1	Rb 2
1	17.2 0.8	51.3 2.2	10	12.4 0.5	58.5 1.8	19	12.4 0.7	42.6 1.3
2	8.7 0.6	36.1 1.4	11	8.6 0.7	36.0 1.3	20	18.2 1.1	55.5 2.7
3	4.4 0.7	26.9 1.3	12	9.6 0.5	43.8 1.4	21	15.9 1.0	54.1 2.3
4	4.9 0.2	38.3 2.1	13	10.6 0.5	42.6 2.2	22	17.5 0.9	46.4 1.5
5	10.4 0.7	53.9 2.6	14	11.2 0.7	45.7 1.5	23	16.2 0.9	49.4 1.5
6	9.5 0.8	60.0 4.0	15	8.7 0.4	44.2 2.4	24	6.0 0.6	36.7 2.1
7	7.5 0.6	38.1 1.1	16	15.2 1.0	52.2 2.0	25	19.3 0.7	59.1 2.0
8	7.7 0.5	36.5 2.1	17	15.6 0.6	58.3 2.1	26	10.2 0.7	57.4 1.8
9	11.7 0.7	58.0 2.4	18	11.7 0.5	54.8 2.3			

Table 4.10: Mean size and standard deviation of rulebases containing rules of high belief for left-turn maneuver prediction

is also similar. This is best depicted by the different sizes of the rulebases Rb 1 and Rb 2 in table 4.10. In general, Rb 1 contains a relatively low number of rules, which indicates that only a small number of rules appear in left-turn maneuvers more often than in any other driving situation. This number is increased substantially when the indicator signal is added to the configuration (Rb 2). Now, many rules that previously did not characterize a left-turn maneuver become good predictors. This effect can also be seen when comparing rulebases Rb 1 and Rb 2 or Rb 3 in table 4.6, which indicates the importance of the duration of the throttle and braking behavior, respectively.

With regards to the requirements for a driver model mentioned in section 3.1, the driver models predicting left-turn maneuvers meet all three requirements. The argumentation is analogous to that from section 4.2.4 due the strong similarities between rulebases for the two types of maneuvers as discussed above. The rulebases are small enough to be evaluated efficiently in real-time during the prediction process and do not require much storage space. They are also small enough to provide traceability of the results by inspecting the state machines. No explicit example is provided, but a similar analysis to that given for the state machine for stopping maneuver prediction is also possible for the driver models predicting left-turn maneuvers.

5

A driver-adaptive longitudinal emergency braking algorithm

In the last chapter, the driver model developed in this thesis was evaluated using sample maneuvers. Knowledge about the driver's intentions could be used to implement novel or adapt existing driver assistance systems. One area with high potential for improvement by driver-adaptive algorithms is that of CM (see section 1.5). In this chapter an example for a driver-adaptive CM system is presented in the form of a driver-adaptive autonomous braking algorithm. This algorithm is then evaluated using a simulator study and a relevant critical scenario.

5.1 A detailed overview of Collision Mitigation

A short overview of CM systems was already provided in section 1.4.4. Since the topic of this chapter is an emergency braking algorithm, which is an integral part of most CM systems, different approaches describing such algorithms are presented. There are two main strategies, one that exploits vehicle dynamics in assessing the criticality of a situation and another that focuses on specific scenarios and/or driving behavior in normal and critical situations. Since the algorithm developed here is of the latter kind, examples for that type are discussed later in this chapter. The concepts behind CM systems based on vehicle dynamics alongside some examples using that approach for the development of autonomous braking systems are presented here.

5. A DRIVER-ADAPTIVE LONGITUDINAL EMERGENCY BRAKING ALGORITHM

One example of a strategy for a CM system developed by Mercedes Benz was presented in Fig. 1.6. The activation times of the different parts (collision warning, partial brake and full brake) are consistent with the findings published by Winner [4] in Fig. 5.1. The values for TTC depicted there are based on the assumption that both

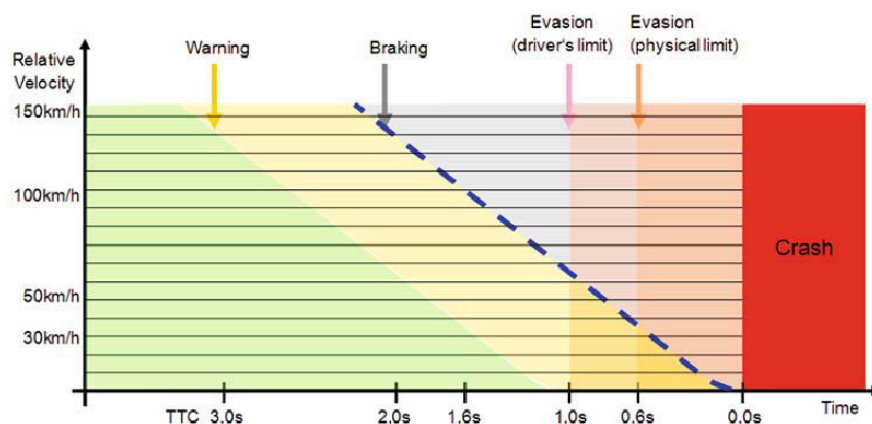

Figure 5.1: Activation times for a CA/CM system, taken from [4]

vehicles drive at a constant relative velocity without accelerations. These values vary if any of the vehicles decelerates or accelerates. The TTC increases, for instance, if the leading vehicle performs a full brake, unless the second vehicle also decelerates with the same factor. Of special interest is the point where a collision is unavoidable, since most current systems available in commercial vehicles only perform an autonomous full brake in that case. According to Winner, a collision cannot be avoided with steering or braking at a TTC of around 0.6 seconds given a relative velocity of around 30 km/h, which is a realistic scenario in urban environments. In continuation, some examples for algorithms that calculate the activation time for an autonomous brake are presented, followed by the algorithm developed in this thesis.

Some authors exploit vehicle dynamics to determine the danger, estimating whether the driver is still able to prevent the collision by steering, braking or accelerating within physical and human constraints. A good example is provided in [105], where the authors provide a detailed description of the trajectories a vehicle can possibly follow given limited steering and acceleration possibilities. The trajectories using a maximal acceleration of $a = 10m/s^2$ with a vehicle velocity of $v = 20m/s$ are displayed in Fig. 5.2. The thick lines represent those trajectories with the highest lateral acceleration.

5.1 A detailed overview of Collision Mitigation

Kaempchen et al. argue that it is necessary to account for all, even the most extreme,

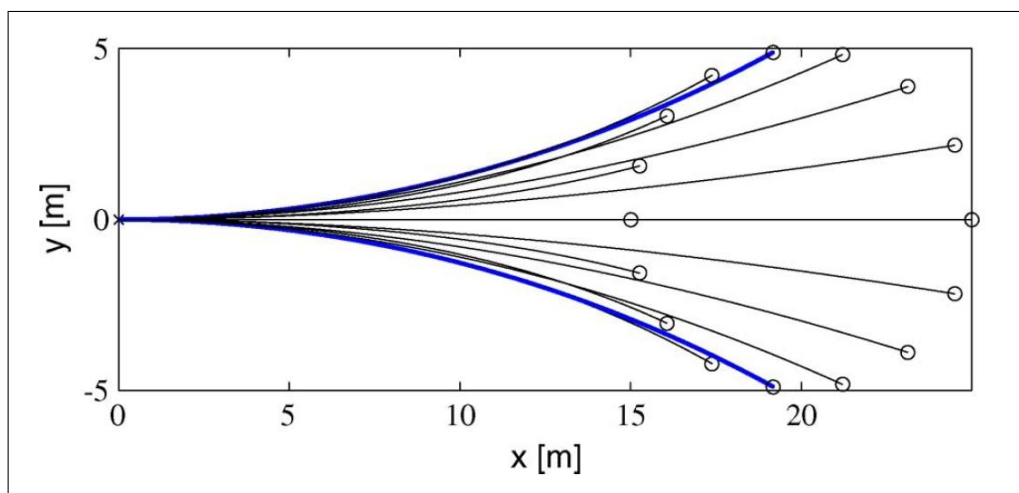

Figure 5.2: Possible trajectories for collision avoidance, taken from [105]

maneuvers in order to avoid activating a CM system when a collision can still be avoided by the driver. A wrong activation causes a false alarm with potentially dangerous consequences if not expected by the driver, since it is a serious intervention in the driving task. Only activating the system when the collision is unavoidable is the only option for ruling out false alarms, provided that the input data to the algorithm is correct. The work compares its results to a similar approach developed by Kopischke [106], who follows a similar line of argument. Another similar strategy is presented by Brännström and colleagues [107].

Other systems have been implemented that also use vehicle dynamics for the assessment of criticality, but which do not compute physical limits for collision avoidance. Labayrade and colleagues [108] developed a CM system that calculates a warning area in front of the vehicle through the prediction of the vehicle's movement for one second based on its velocity, yaw rate and width. If an object enters the warning area and a number of constraints are fulfilled (the objects are valid, the predicted TTC is below one second and the object and the warning zone overlap), a signal is sent to the braking system and an emergency brake performed. Here, instead of allowing full maneuverability by the driver, it is assumed that the driver does not react to the danger in any way. This is an assumption that need not be true for every driver, which could lead to

5. A DRIVER-ADAPTIVE LONGITUDINAL EMERGENCY BRAKING ALGORITHM

false alarms.

An example of an autonomous braking system that lies in between these is the method developed by Zhang and colleagues [109]. They activate an emergency brake based on the time-to-last-second-braking (T_{lsb}). This measure is calculated as the time the driver has until he needs a full brake to avoid a collision under the assumption that both vehicles decelerate with constant values until the point of T_{lsb} is reached. In order to reduce the probability of a false alarm, an emergency brake is only performed if $T_{lsb} < 0.5$ s.

The main advantages of the methods computing physical collision avoidance limits are their universality and robustness. Due to the simultaneous consideration of all possible trajectories most collisions are addressed appropriately without any further situation analysis. And since the trajectories are only limited by physical laws, there are no false alarms unless faulty sensor data is fed into the algorithm or the vehicle breaks free of normal physical constraints, for instance while skidding. The downside is the very late activation of the autonomous brake, leading to a substantial loss in effectiveness of the CM system. In many situations, the actual point where the collision is unavoidable is long before the physical collision avoidance limits presented in Fig. 5.1. A variety of reasons, for instance human limitations or environmental factors like wet or icy roads, can lead to higher TTC values where the collision cannot be avoided by the driver. Knowledge of environmental factors, such as blocked escape routes or icy roads, could be included in these algorithms to provide a higher effectiveness. The driver's behavior cannot be included in the calculation, since the design of these algorithms is such that all possible reactions by the driver are allowed. Hence, even though activating a CM system only when a collision is not avoidable is a valid approach that addresses almost all possible traffic situations, much effectiveness is lost due to the late activation time.

A promising approach is to combine such a general approach with a number of specialized algorithms for highly specific situations. Detailed knowledge about the driver and the specific situation could be used to optimize the activation strategy in that scenario, falling back to an algorithm based on vehicle dynamics in the remaining critical situations where no such information is available. To illustrate how such a specialized algorithm could look like, a prototypical algorithm is developed and validated in the remainder of this chapter.

5.2 Description of the emergency braking algorithm

In this section, the braking algorithm developed in this thesis is presented. The core of the algorithm is the detection of a critical situation and identification of the driver’s intention in the face of that situation. The algorithm is designed to perform an autonomous brake in the specific scenario described below. However, the principles behind the algorithm are not limited to that scenario and could be adapted to other situations that might need autonomous braking to avoid or mitigate the collision.

5.2.1 Definition of the critical situation

Collisions in longitudinal direction, rear-end and heads-on collisions, are two of the most prominent types of accidents. According to an accident analysis made by BAST¹ (the German Highway Research Institute), a large number of collisions is caused in longitudinal situations. According to their statistics, 35% of the collisions with fatal outcome, 27% with serious injuries and 39% with light injuries were caused by longitudinal accidents [110]. They are the prime source of accidents with light injuries, and second when the collision had fatal consequences. A detailed itemization of longitudinal accidents depending on the respective severity is shown in Fig. 5.3. Heads-on collisions

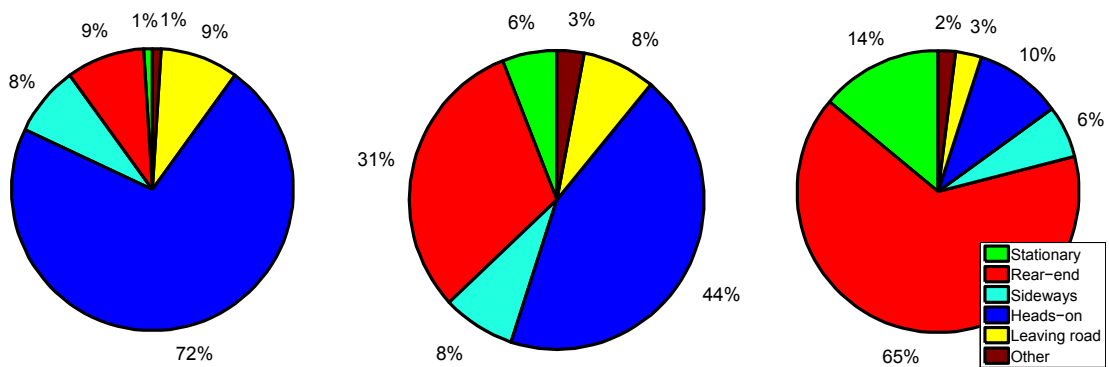

Figure 5.3: Accident causes for collisions involving lethal, heavy and light injuries, taken from [110]

make up 72% of the fatal collisions, while rear-end collisions cause an almost equally high percentage of cases (65%), albeit a much higher absolute number of cases, when

¹<http://www.bast.de>

5. A DRIVER-ADAPTIVE LONGITUDINAL EMERGENCY BRAKING ALGORITHM

only light injuries are involved. This difference in severity can no doubt be attributed to the substantially different collision velocities in the two scenarios.

As a result of this and other data from accident analysis, BAsT extracted three longitudinal scenarios that ought to be included in the evaluation of the performance of forward collision systems. The three scenarios are shown in Fig. 5.4. It can be expected

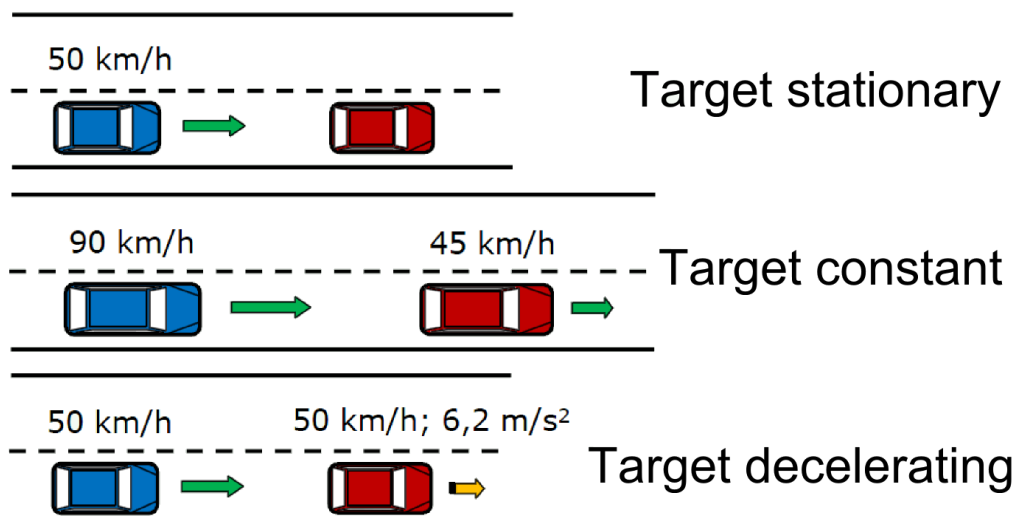

Figure 5.4: Evaluation scenarios for CM systems, taken from [110]

that test procedures based on these and other scenarios will be included in Euro NCAP¹, an established and renowned European test that rates the safety of commercial vehicles. The goal is to assess the quality of the CA / CM systems, prominently autonomous braking systems, available in commercial vehicles. Hence, a good performance of a CM system in these types of scenarios from Euro NCAP has high practical relevance as well as a potentially large contribution to the company's image with respect to the safety of its vehicles. The algorithm developed in this chapter uses the third of the above scenarios as target scenario for the evaluation. This choice ensures that the algorithm addresses a relevant traffic scenario and, if designed properly, generates a substantial benefit for both the car company and the driver. Given this critical scenario, the algorithm presented in this chapter is based on two main criteria, a driver-

¹www.euroncap.com

dependent criticality measure and the driver intent as predicted by a driver model. These two components are discussed in the next sections, followed by a description of the algorithm.

5.2.2 Driver-dependent measure of situation criticality

One of the key aspects is to measure the situation's criticality. In the example from Fig. 5.2, the criticality is inferred through the evaluation of possible driver responses. The higher the need for lateral or longitudinal acceleration to avoid a collision, the higher the criticality. Other approaches do not use vehicle dynamics but focus on the traffic situation and/or the driver's behavior. In longitudinal scenarios, such as head-on or rear-end collisions, the criticality of a situation is often measured using a safety distance [111], Time Headway or TTC ([112],[113],[114]) as the main criterion. Vogel [115] compared Time Headway and TTC as measures for criticality. Her results were that Time Headway is a good measure for potentially dangerous situations and should be used for enforcement purposes, while TTC should be used to determine the actual occurrence of a dangerous situation. Depending on the application, specific thresholds, usually defined by the system designer(for instance in [108],[111]), are used as trigger points.

Sometimes these thresholds are adapted to the individual driver. In McCall and Trivedi [116], the probability of a situational need for braking is calculated by accumulating vehicle and sensor data in labeled situations (critical and uncritical), critical situations being classified as such if the TTC to a preceding vehicle was below a certain threshold and heavy braking was required to avoid a collision. A threat assessment based on statistical modeling is presented by Eidehall and Peterson [117]. This is an extension of the purely physical methods reviewed in 5.1. Both concepts share the prediction of future states of the vehicles, the difference being that the statistical model calculates probabilities for individual trajectories and prediction times. This makes sense, since not all possible trajectories are equally likely. In a probabilistic framework it is possible to include information from various sources, Eidehall and Peterson for instance add visibility constraints in the calculation of the probabilities, since a driver is less likely to adopt an evasive trajectory if the obstacle is not directly visible. The result is a probability distribution for a collision which can be used to activate CA or CM systems.

5. A DRIVER-ADAPTIVE LONGITUDINAL EMERGENCY BRAKING ALGORITHM

In the algorithm developed in this thesis, the calculation of the criticality of a situation is similar to the method developed by McCall and Trivedi. The measure is based on a conditional histogram of Time To Collision in stopping maneuvers. For each sample maneuver (see Fig. 4.10), the TTC to the preceding vehicle is calculated whenever the driver's speed exceeds 15 km/h (to avoid low TTC values due to slow velocities and short distances) and the driver brakes with a brake pressure of at least 8 bar, which, according to the histograms of brake pressure presented in section 4.2.1, is a reasonable minimum pressure indicating a desire to actually perform a braking maneuver. The TTC was chosen above other possible measures, because according to Vogel in [115], it measures the actual occurrence of a dangerous situation. Using the resulting histogram, a fuzzy variable describing situation criticality is generated using the method described in section 3.3. One example of such a variable for one driver of the field study is shown in Fig. 5.5. The remaining variables are presented in Appendix C.

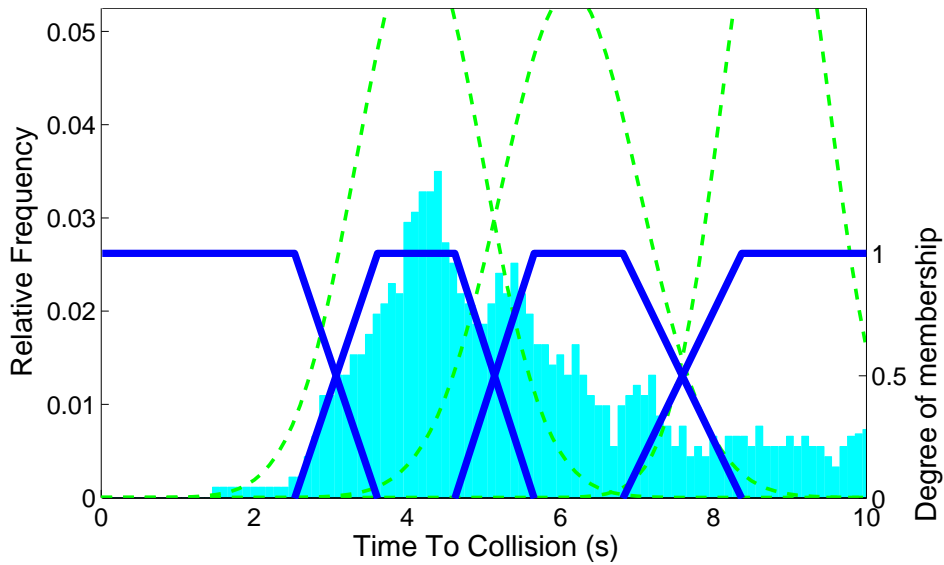

Figure 5.5: Fuzzy variable for situation criticality

In the case of an emergency braking algorithm, the fuzzy set of interest is the leftmost set, which indicates high criticality. If the TTC is within that range, the driver in most cases already activated the brake before reaching the current state. If no

5.2 Description of the emergency braking algorithm

reaction is detected, it can be argued that the driver is not fully aware of the situation and, under certain circumstances as dictated by the target scenario, an emergency brake could be activated. Whenever a criticality value is mentioned in the remainder of this chapter, it is the TTC value of the right edge of the leftmost set's base, which for the example in Fig. 5.5 is 2.5 seconds.

5.2.3 Prediction of driving intent in critical scenarios

The other central component is the interpretation of driving behavior prior and during a critical situation. A situation can be substantially more dangerous if the driver is not fully aware of his surroundings and therefore unable to react properly. Detecting the driver's behavior, or the lack of it, provides valuable information for a CA/CM system that could be used to improve effectiveness as well as consumer acceptance. This can be done by modeling the driver's normal behavior in a given situation with subsequent detection of abnormalities. How driving maneuvers can be predicted was discussed in chapter 2. Here, methods are presented that specifically address the driver's behavior in critical situations, either by detecting abnormalities or by modeling braking behavior explicitly.

Kamal and colleagues [118] use distance and acceleration when following a lead vehicle to detect abnormalities. They designed a fuzzy model that consists of fuzzy variables for the distance and acceleration differences between observed and current behavior and one output variable with five fuzzy sets ranging from 'Zero Abnormality' to 'Extreme Abnormality'. They then generated a rulebase that maps each of the possible input configurations to one output set. This idea was embedded in an agent-based framework and evaluated using a simulator study by Poitschke and colleagues [119].

Even if a driver does react by braking in response to a critical situation, his braking force is often not high enough to prevent a collision. In order to provide an optimal assistance, attempts have also been made to detect whether a driver is performing a regular braking maneuver or an emergency brake, without additional sensor information about the presence of an obstacle. ([120], [24], [121]).

In the approaches mentioned above, the source of the driver's behavior is unknown, since only the data available from the interaction between the driver and the vehicle is available. In certain scenarios, it is possible to a certain extent to infer the driver's state

5. A DRIVER-ADAPTIVE LONGITUDINAL EMERGENCY BRAKING ALGORITHM

from behavioral data alone. For instance, Alonso and colleagues investigated the effect of distraction on longitudinal driving behavior in a simulation study [122]. Cooper [123] investigated the effect of distraction on gap acceptance in turning situations. These effects can be used to calculate a level of distraction in that particular scenarios. Video cameras that detect parts of the driver (usually the head) can be used to detect the driver's state directly. States such as fatigue or distraction can be detected and used to infer the driver's behavior in critical situations. For instance, it takes a distracted driver longer to identify a dangerous situation. It can also be ruled out that, when distracted, a driver is planning corrective action in the form of braking or steering. McCall and Trivedi [116] estimated driver intent using data from four sources, a camera observing the driver's face, one aimed at the driver's foot and vehicle sensors for steering angle and accelerator position. As with criticality assessment, the data that was used for the estimation of the probability distribution was split into two classes, 'planning a breaking action' and 'normal driving'.

As was mentioned above, there are a variety of possibilities how the driver intent can be inferred, either indirectly through his interaction with the vehicle, or directly using cameras. The disadvantage of the direct method is the need for cameras in the inside of the vehicle, which are as of now only included in a limited number of premium class vehicles. In this thesis the driver intent is detected using the driving maneuver prediction method developed in chapter 3. Depending on the situations to be addressed by the emergency braking system, driver models are generated for those maneuvers that can be performed to deescalate the situation. Each of the models predicts one such maneuver, and if none of the driver models is able to predict its respective maneuver in the presence of a critical situation, an abnormality in driving behavior is deduced. This abnormality, the criticality of the situation and possibly other circumstances specific to the situation are used to decide whether an emergency brake should be performed. For the target scenario described in section 5.2.1, the potentially relevant maneuvers are 'stopping behind a leading vehicle' and 'changing lane', which depends on the amount of space to the left and right of the vehicle.

5.2.4 Description of the emergency braking algorithm

For an emergency brake to be activated in a specific situation, the first step of the algorithm is to detect the presence of that situation. In the case of the chosen scenario,

5.3 Evaluation of the emergency braking algorithm

the speed of both vehicles as well as the deceleration of the target vehicle need to be measured. The target situation occurs whenever the vehicles drive with approximately same velocities (for instance 50 km/h) and the leading vehicle decelerates strongly with at least $a = 6.2m/s^2$. If the target scenario is valid, the TTC is calculated and the individual criticality value as described in 5.2.2 evaluated. If the TTC lies within the criticality threshold, the driver intent is analyzed, otherwise the algorithm awaits the further development of the situation. If a reaction is predicted, the algorithm aborts without activation, since the driver is responding to the situation. If no driver reaction is observed in the presence of a critical situation, a second threshold for the TTC is considered. If the TTC is below 1.5 s, the emergency brake is activated. This second threshold is necessary because activating a brake based only on the individual criticality value could cause false alarms, since the maneuvers from which the measure was derived were not critical. The mean criticality value for the participants of the field study was 2.27 s (with a standard deviation of 0.36 s), which is too high a value to activate an autonomous braking system. The threshold of 1.5 s was chosen based on the findings by Svensson in his doctoral thesis [114], in which he suggests this value as safety limit for urban environments. Fig. 5.6 shows a flow chart of the algorithm. The algorithm can also be modeled as a (fuzzy) rulebase, providing a seamless integration with the driver modeling method implemented in this thesis. Another advantage is the easy expandability of the model through rules modeling the system behavior in other relevant scenarios. This results in a complex rulebase defining the behavior of an autonomous braking system that accounts for a variety of specialized critical scenarios in a driver-adaptive way.

5.3 Evaluation of the emergency braking algorithm

To be able to measure the performance of the algorithm, a field study needs to be designed and carried out. The false-alarm rate, the unnecessary activation of an autonomous brake, can in principle be estimated through a study in real traffic like the one described in 4.1. However, since the system is only activated if the leading vehicle brakes with a deceleration of at least $6.2m/s^2$, this is not a situation often found under normal traffic circumstances. As it turns out, no false-alarms were observed for any of the 26 participants of the study used to evaluate the driver modeling method. Even

5. A DRIVER-ADAPTIVE LONGITUDINAL EMERGENCY BRAKING ALGORITHM

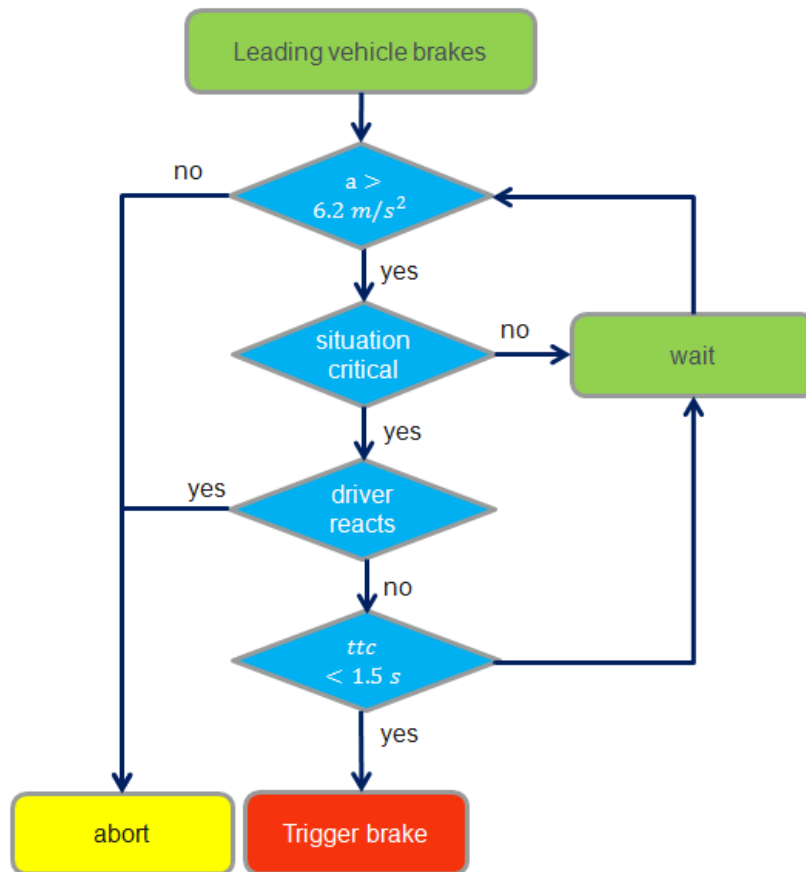

Figure 5.6: flow chart of the autonomous braking algorithm

if the situation is artificially engineered in real traffic, which is a dangerous task, it is not possible to assess the effectiveness of the algorithm under real traffic conditions, since it is very likely to involve actual collisions. As a consequence, a study in a driving simulator is the only viable option. The design of the simulator study, the application of the algorithm described above to the data obtained in the study and its evaluation are the topics of this section.

5.3.1 The simulator study

The simulator study described here was developed in cooperation with the Institute of Transportation Systems at DLR¹, the German Aerospace Center. The Institute oper-

¹<http://www.dlr.de/ts/en/>

5.3 Evaluation of the emergency braking algorithm

ates a number of driving simulators, including a dynamic driving simulator¹. This study was carried out in the static driving simulator located in the VR-Lab². The simulator consists of a regular seat, steering wheel, pedalboard, gearshift and a center console that provide the most important instruments found in a real vehicle. The projection area is divided into three perpendicular screens, offering a 270° stereo projection. Fig. 5.7 shows the driving simulator during an experiment. In order to address the target



Figure 5.7: View of the driving simulator, courtesy of DLR

scenario, an inner-city setting was designed. The driving route with a total length of 15 km can be seen in Fig. 5.8. The roads consisted of two lanes, one in each direction, and it took the drivers approximately 25 minutes to finish the course. In order to provide a realistic environment, an evenly distributed number of oncoming vehicles was included, making it difficult for the driver to overtake a preceding vehicle by simply switching to the oncoming lane.

Since the focus of the study was to analyze the autonomous braking algorithm, a number of relevant longitudinal scenarios at intersections involving traffic lights and leading vehicles were included in the study. The yellow and red circles in Fig. 5.8 correspond to traffic lights that turned red, forcing the vehicle to stop at the intersection.

¹http://www.dlr.de/fs/en/desktopdefault.aspx/tabid-1236/1690_read-3257/

²http://www.dlr.de/fs/en/desktopdefault.aspx/tabid-1236/1690_read-3255/

5. A DRIVER-ADAPTIVE LONGITUDINAL EMERGENCY BRAKING ALGORITHM



Figure 5.8: Design of the simulator study

Those marked yellow switched from green to yellow four seconds before the vehicle reached the intersection, providing enough time to react and perform a smooth stopping maneuver. For the red circles, on the other hand, the lights turned to yellow 2.5 seconds before reaching the intersection. Since the yellow phase only lasted 1.5 seconds, it was necessary to react quickly and brake more strongly to avoid passing a red light. To prevent the driver from reacting to every traffic light, a number of green lights were also included in the study. These lights did not change, allowing the driver to cross or turn at the intersection unhindered. In half the scenarios there were no vehicles in front, while in the other half the subject followed another vehicle that, depending on

5.3 Evaluation of the emergency braking algorithm

Scenario	Without LV	With LV
Green light	3	4
Easy light	5	5
Difficult light	4	4

Table 5.1: Number of longitudinal scenarios in the simulator study

the distance between the vehicles, also had to stop at the traffic light. At the end of the course, the leading vehicle stopped abruptly and unexpectedly 50 meters ahead of the intersection. This led to the target scenario the algorithm was designed for. Hopes were that a number of participants would not react in time and produce a collision with the braking vehicle, leading to the activation of the emergency brake. The other scenarios were used to implement the algorithm and provide near-critical situations for the evaluation of false alarms, especially the late traffic lights with a leading vehicle. The total number of scenes are summarized in table 5.1.

In addition to the longitudinal scenarios, a large number of turning scenarios involving the host and/or leading vehicle were also part of the study. These were not analyzed explicitly, unless a turning maneuver by the leading vehicle forced the driver to stop behind him, as will be mentioned later. The remaining time was approximately evenly distributed between having the driver either follow the leading vehicle or drive at his preferred speed without hindrance.

A total number of 20 subjects participated in the study. In contrast to the field study, efforts were made to control the participants according to three criteria. All participants had already been in a simulator and also drove a training course before starting the trial. This was done to minimize effects related to the unusual driving experience found in simulators compared to driving real vehicles. Since a part of the algorithm is to model normal driving behavior, having to model maneuvers based on erratic or inconsistent driving behavior due to this unfamiliar environment could cause problems not found under normal circumstances. Besides controlling the simulator experience, the focus lay on an even distribution of gender and age. Unfortunately, due to a high number of female participants who had to abort the experiment due to simulator sickness, more male (77%) than female participants concluded the study. The age of the subjects was roughly evenly distributed between three age groups: 20-30, 30-40 and 40-50 years of age.

5. A DRIVER-ADAPTIVE LONGITUDINAL EMERGENCY BRAKING ALGORITHM

ID	1	2	3	4	5	6	7	8	9	10
# maneuvers	8	11	13	12	14	7	7	11	8	11
ID	11	12	13	14	15	16	17	18	19	20
# maneuvers	14	9	4	14	7	12	15	11	12	9

Table 5.2: Number of stopping maneuvers in the simulator study

5.3.2 Implementation of the emergency braking algorithm

The algorithm from section 5.2 is evaluated using the data from the simulator study. The two main components, the measure of situation criticality and the prediction of driver intent, are presented in this section.

The measure of criticality is calculated in the same manner as in section 5.2.2. The histogram of the Time To Collision in stopping maneuvers is generated using all sequences where the driver had to stop behind a leading vehicle. The sample stopping maneuvers were extracted with the same method described in section 4.2.2 that was used in the field study. There was a large difference in the number of stopping maneuvers between participants, ranging from only 4 to 15 maneuvers. The reason was that drivers who preferred to keep a large distance to the leading vehicle rarely needed to stop behind it, either because the leading vehicle crossed the intersection before the traffic light switched color, or because it had already turned at the intersection before the vehicle reached it. Drivers who kept a low distance, on the other hand, stopped behind a vehicle in most or all of the scenarios from table 5.1 involving leading vehicles, as well as other scenarios, for instance when the leading vehicle turned at an intersection. Table 5.2 lists the number of stopping maneuvers for each of the participants.

For each driver, the conditional histogram for TTC was derived from these scenes and the fuzzy variable describing situation criticality calculated. The range of different driving behavior, from higher to lower criticality, is depicted in Fig. 5.9. The variables for all 20 drivers are presented in Appendix D.

In the simulator study most drivers kept lower distances to leading vehicles than in the field study. In this study, the mean criticality value is 1.81 s, which is almost half a second lower than in the field study, with an almost equal standard deviation of 0.32 s. This phenomenon can mostly be explained by the lack of real danger found in a

5.3 Evaluation of the emergency braking algorithm

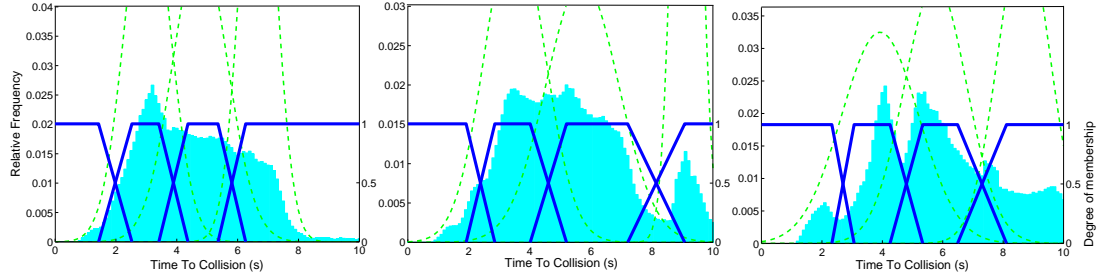

Figure 5.9: Fuzzy variables for situation criticality from the simulator study

simulator environment, the high concentration of potentially critical scenarios as well as the different sensation when driving a simulated car.

For the prediction of driver intent, a driver model for the maneuver 'stopping behind a leading vehicle' was generated from the sample stopping maneuvers. Models for lateral behavior such as lane changes were not modeled. Since the roads consisted of only one lane in each direction and there was a steady flow of oncoming traffic, it was difficult for the driver to overtake a leading vehicle without considerable risk. Given that in the situations encountered in the simulator study the relative velocities were never higher than approximately 40 km/h, the physical limits for braking and steering depicted in Fig. 5.1 are similar, braking even being the better option. As a matter of fact, no attempts were made to change the lane by any driver, not even in the critical situation. It is therefore sufficient in this case to predict the driver's behavior exclusively from his longitudinal behavior.

For the driver model the same fuzzy variables introduced in section 4.2.1 were used. The data from the entire route was used for the construction of the histograms. These fuzzy variables provide accurate profiles for the individual variables for each of the drivers. The results from the Leave-one-out cross-validation method applied to the trained models are presented in Fig. 5.10. Since the autonomous braking algorithm can potentially cause premature activations of the brake if the driver is planning or conducting a stopping maneuver which is not recognized by the model, it is of high importance for the driver model to exhibit a high prediction rate. The false-alarm rate, predicting a stopping maneuver even if it is not the case, is less important. A high false-alarm rate reduces the effectiveness of the algorithm, since a relevant maneuver might be predicted in a dangerous situation, even if the driver is unaware of the situation,

5. A DRIVER-ADAPTIVE LONGITUDINAL EMERGENCY BRAKING ALGORITHM

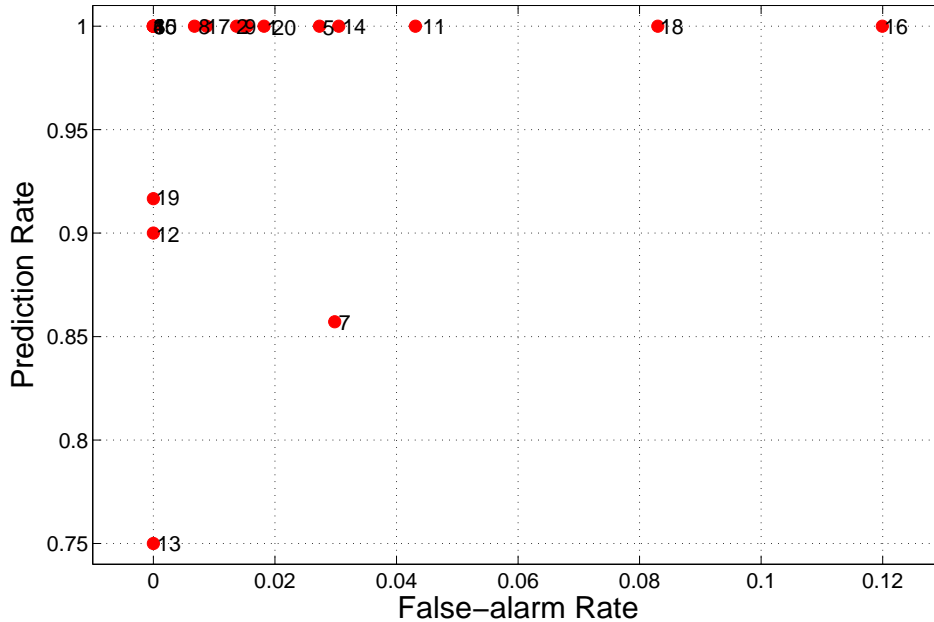

Figure 5.10: Cross-validation results for stopping maneuver prediction in the simulator study

causing the system to refrain from activating the brake. In this case, a high prediction rate that prevents premature activations with a possibly lower effectiveness needs to be favored over a driver model that has a low false-alarm rate but might activate the brake without necessity. This motivates the choice of setting $\beta = 0.1$ in Eq. 3.19, thus favoring precision over recall.

As can be seen from Fig. 5.10, for most drivers all stopping maneuvers were predicted correctly. In four cases, one of the maneuvers was not classified correctly. All of the unclassified examples were very similar. In each case, the maneuver in question was a highly unusual maneuver that differed substantially from those maneuvers used for training. For three of the drivers, the driver first turned at an intersection very slowly, after which a car stood waiting for the vehicle to approach before accelerating. This behavior was necessary to make sure that a car-following sequence would develop. The trigger algorithm for the leading vehicle to start driving included a minimum velocity of the driver’s car, which in this case was never reached. As a consequence, the driver approached the standing vehicle with a low speed and came to a full stop behind it.

5.3 Evaluation of the emergency braking algorithm

Only then did the leading vehicle accelerate. Such a maneuver happened only once for those three drivers in question. In the case of driver 19, the driver triggered a strong brake on a straight segment behind a standing vehicle at an unusually high distance of approximately 30 meters. The rest of the maneuver was identical to that described above. This was the first stopping maneuver the driver had to perform, where he still was unfamiliar with the vehicle's braking behavior. All of these maneuvers were in no way critical and did not lead to a false activation of the algorithm, as will be discussed in the following section.

5.3.3 Evaluation of the emergency braking algorithm

Given the criticality measures and driver models described above, it is possible to evaluate the algorithm using the data from the simulator study. The goal of the evaluation is to measure the performance of the algorithm as measured by its effectiveness as well as the false-alarm rate. The effectiveness of an autonomous braking algorithm can be computed in various ways. In [105] and [106], the amount of energy reduced by performing the autonomous brake is computed as the difference between the initial energy and the remaining energy when the vehicles collide. A related measure is the difference between initial and collision velocities. A third possibility, which is more convenient in this case given that no actual autonomous braking was performed during the experiments, is to compare the TTC when the brake would have been activated to the TTC at the time the driver began braking himself or to the TTC values suggested by Winner (see Fig. 5.1). The advantage of this measure is that it can be applied both to correct activations and false-alarms, making it easier to compare the two types of information. False-alarms are those activations of the algorithm when no collision occurs and the driver does not perform a stopping maneuver. There is a gray area in between correct and incorrect activations. This happens when the system would have braked before the driver himself initializes a braking maneuver. Even though this is not a false-alarm in the strict sense, it can have a substantial impact on consumer acceptance if the autonomous activation comes ahead of time. An activation of this kind will be called premature alarm in the continuation of this chapter.

As a first step it is necessary to identify the critical situations. Critical situations are those where all situational requirements for the algorithm (target decelerates, TTC is within the driver-dependent criticality range and lower than 1.5 s) are met. Based

5. A DRIVER-ADAPTIVE LONGITUDINAL EMERGENCY BRAKING ALGORITHM

on the design of the study, hopes were that at least one such situation would happen at the end of the experiment when the leading vehicle brakes unexpectedly before reaching the last intersection. Since the drivers were not distracted in any way, the situation was only critical if the distance between the vehicles was sufficiently low at the time the target started braking. Other sources of potentially dangerous situations were those stopping scenes at intersections where the traffic light changed late and there was a leading vehicle (the red circles with black borders in Fig. 5.8). In those scenes, if the distance between the vehicles was sufficiently low, the leading vehicle also had to brake strongly when the light switched from green to yellow, also leading to the critical situation the algorithm is designed for. Table 5.3 lists all the scenarios and actual collisions, as well as the number of correct, premature and false activations of the autonomous braking algorithm presented in this chapter, omitting those drivers who displayed a very conservative driving style which lead to no critical situation during the experiment.

ID	Critical	Collision	Activations	Premature	False alarms
1	1	0	0	0	0
3	4	0	0	0	0
4	4	1	3	2	0
5	5	0	0	0	0
6	1	1	0	0	0
8	1	0	0	0	0
10	4	2	2	0	0
11	4	0	0	0	0
12	4	1	1	0	0
14	1	0	0	1	0
15	1	0	0	0	0
16	5	4	2	0	0
17	5	1	0	0	0
18	2	0	0	0	0
19	3	0	0	1	0
20	4	2	2	0	0

Table 5.3: Analysis of critical situations in the simulator study

5.3 Evaluation of the emergency braking algorithm

From all 20 subjects, only four encountered no critical scene due to their defensive driving style. All other had at least one critical scenario, usually the one at the end of the experiment, and some encountered many, in some cases even up to five, critical scenarios. Those critical scenarios, however, did not necessarily end in collisions. As a matter of fact, in most cases the driver managed to avert a collision by braking quickly after the target vehicle started braking. In most of those cases, the respective driver models managed to predict the behavior correctly and inhibited an unnecessary autonomous brake. This shows the relevance of the driver model developed in this thesis for the adaptation of CM systems. The prediction of maneuvers is largely responsible for avoiding triggering a premature autonomous brake. Many drivers, such as those with ID's 3, 5 or 11, encountered several subjectively critical situations that they were able to resolve without the need of assistance. Through the prediction of maneuvers, the algorithm was provided with the necessary situation awareness to be able to only provide assistance when needed. As a consequence, not a single false-alarm and very few premature alarms were observed. The prediction of driver behavior makes it possible to trigger an autonomous brake early enough to prevent collisions, as will be shown in table 5.4, without the usual drawback of also causing an increase in undesired activations.

Seven drivers were involved in collisions, sometimes even more than one, as can be seen in the third column. In most of the collisions the autonomous braking system would have been triggered. For drivers 6, 16 and 17 there would not always have been an activation, as can be derived from the third and fourth column. The reason was that the driver models predicted a stopping maneuver and hence inhibited the triggering of the autonomous brake. The prediction was correct, all drivers did brake, but they did not brake enough to avoid the collision. All these cases can be addressed by braking assistance systems that increase the braking force if the driver does not brake hard enough in that particular situation.

There were no situations in which the algorithm triggered a brake while the driver did not need to brake himself to avoid or mitigate a collision, and hence no false-alarms in the strict sense. There were, however, four instances where the algorithm did get triggered but the driver managed to avoid the collision himself. These scenarios are the premature alarms summarized in column five. As was mentioned previously, it is important to analyze the temporal differences between the hypothetical triggering of an autonomous brake and when the driver pressed the brake pedal himself. Only if

5. A DRIVER-ADAPTIVE LONGITUDINAL EMERGENCY BRAKING ALGORITHM

ID	Correct Δt	Correct TTC	Premature Δt
4	0.34	1.46	0.01, 0.14
10	0.4, 0.7	1.33, 1.3	
12	0.2	1.14	
14			0.06
16	0.17, 0.25	1.38, 1.41	
19			0.015
20	0.2, 0.26	1.49, 1.49	

Table 5.4: Effectiveness of the autonomous braking algorithm

that difference is high enough to be noticeable it can have a negative effect on customer acceptance.

Table 5.4 shows the performance measures for those 8 cases where the brake did get triggered correctly and the four scenes where the system would have been activated before the driver braked and managed to avoid the collision. The four bold entries in the second and third column represent the activations of the algorithm in the designed critical scenario, whereas the other four constitute collisions that occurred at other times during the experiment, in situations where the leading vehicle had to perform a strong brake to avoid running a red light.

The second column displays the time differences between the hypothetical activation of the autonomous brake and the begin of a driver-triggered brake in those situations where a collision occurred. This represents the time that could have been gained by the algorithm in order to reduce the severity of the collision further or even avoid it altogether. The mean increase in braking time was 0.31 seconds. Note that this measure depends on the time at which the driver braked himself. If the driver reacts very late, as for instance in the second collision of driver 10 analyzed in more detail below, the benefit of the algorithm is increased. In that particular scene the algorithm would have triggered 0.7 seconds before the driver reacted. All drivers reacted by braking to avoid the collision, which, given the results of the In Depth accident analysis discussed in section 1.5 is not the case under real traffic conditions, where a large proportion of the drivers did not react to the danger and would therefore have gained even more from the system developed in this chapter.

5.3 Evaluation of the emergency braking algorithm

The third column shows the TTC at which the algorithm would have triggered. Since in this specific situation both vehicles brake strongly and therefore the relative velocity remains approximately constant throughout the maneuver, the regions of TTC values where collisions are avoidable as suggested by Winner (see Fig. 5.1) can be used as reference to evaluate if the algorithm would have avoided the collision. All activation times lay left of the dashed line representing avoidance by braking, given that in the target scenario the relative velocity is never higher than approximately 30 km/h. This dashed line assumes instantaneous and full operation of the vehicle's brake. Depending on the vehicle, the time necessary to achieve full braking force as well as the maximum available force in the case of an autonomous brake might be suboptimal, thus increasing the TTC value necessary to avoid a collision. It is therefore not possible to state with certainty if a given TTC would have sufficed to avoid a collision. In most cases, however, the activation times were so high that it is very likely that the collision would have been avoided. The strongest collision was observed in the critical scenario of driver 10, who kept a very low distance and was completely taken by surprise when the leading vehicle braked, causing him to react more than 1.1 seconds after the leading vehicle started braking. The braking algorithm, on the other hand, would have triggered the brake 0.7 seconds before the driver, at a TTC of 1.3 seconds. The collision situation is shown in Fig. 5.11. Even though the system reacted very quickly, it is not certain,

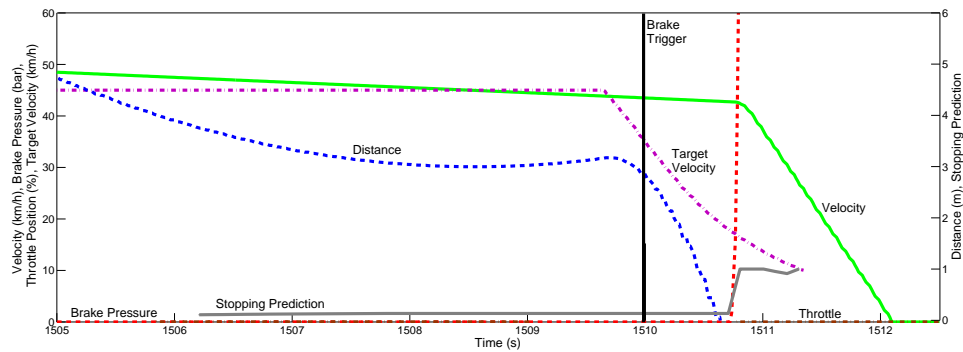

Figure 5.11: Sample collision scenario

however, that the collision would have been avoided, since the driver kept such a low distance at the time the leading vehicle started braking. The necessary time to reach full braking power might potentially be too high to avoid the collision. This exemplifies

5. A DRIVER-ADAPTIVE LONGITUDINAL EMERGENCY BRAKING ALGORITHM

the limits of autonomous braking systems, which need more time to generate the same braking effect than human drivers when performing a full brake.

From the premature activations shown in the fourth column of table 5.4, none preceded the driver's reaction long enough to be considered a wrong activation. The highest temporal difference was of 0.14 seconds, which is barely perceivable by even the most skilled drivers, especially in an emergency situation where cognitive load is high, and would most certainly not have caused the driver to reject the system. All other premature activations were triggered less than 0.1 seconds before the driver braked, a time difference that for all practical purposes can be neglected. Hence, the activation of the autonomous brake would have found the driver's approval in all 12 cases where it was triggered. The absence of wrong or premature activations is largely the consequence of designing the algorithm in a driver-adaptive way. The individual criticality measure, as well as the maneuver prediction, prevent the triggering of activations ahead of time, as can be seen in the data from the third column. For each driver the TTC at which a brake would have been triggered is different, depending on his measure of criticality. For more conservative drivers, such as driver 20, the activation time was close to the TTC threshold of 1.5 seconds. Such an activation could have caused premature activations for less conservative drivers like drivers 10 and, especially, 12, who had a substantially lower criticality value.

As a result, it can be stated that based on the simulator study, the algorithm would have been able to prevent the collisions, or at least reduce the severity by a substantial amount. In spite of the early activation time of the brake necessary to avoid the collisions, no incorrect or premature brake activation was observed, which might have jeopardized the vehicle's safety or lead to low consumer acceptance. Hence, the algorithm provided vital assistance to each individual driver of the study. In some cases, the system would have avoided an otherwise very critical collision resulting in high damage and possibly heavy injuries. This can be seen in Fig. 5.11. The algorithm would have reacted very quickly to the front vehicle braking at a TTC of 1.3 seconds. The driver did react very late and began braking when the relative velocity was approximately 30 km/h and the distance less than 2 meters. In real traffic, this would have caused a serious collision, which would have been reduced to a large extent by the braking system developed in this thesis.

6

Conclusion

In this thesis, I developed a method capable of predicting the individual driving behavior and applied it to the field of advanced driver assistance systems. This driver model uses the theory of fuzzy logic to allow reasoning about the execution of driving maneuvers. The driver-dependent generation of the building blocks of fuzzy logic, fuzzy variables and fuzzy rules, is of central importance in this thesis and was covered in chapter 3. I evaluated the performance of the driver models using two frequent maneuvers, stopping behind a leading vehicle and turning at an intersection in urban environments. To assess the performance, 26 subjects participated in a field study designed to record normal driving behavior. I presented the study, the generation of the driver models using the data from the study and the evaluation of the method's performance in chapter 4. As an example of a driver-adaptive assistance system, I implemented an autonomous braking algorithm that includes the model predicting the driver's stopping behavior in its decision process. To evaluate the algorithm's performance in its target scenario, I designed a simulator study that was carried out in cooperation with the German Aerospace Center (DLR). In chapter 5, I described the study's design, the implementation of the braking algorithm and evaluated it using the data from the simulator study.

I presented the driver model developed in this thesis in chapter 3. In section 3.1, I identified requirements that a driver model needs to fulfill in the context of advanced driver assistance systems and motivated the use of fuzzy logic as modeling method. In section 3.2, I gave a short introduction to the theory of fuzzy logic using a simple

6. CONCLUSION

example from the area of driving maneuver prediction to illustrate the theory's basic principles. The central aspects of the theory, fuzzy variables and fuzzy rules, were the topics of sections 3.3 and 3.4.

In section 3.3, I presented a novel algorithm that provides a partitioning of a quantity of interest into fuzzy sets based on driving data, thereby taking the behavior of the individual driver into consideration. The algorithm is based on the generation of a histogram representing the driver's behavior in a specific environment, such as the vehicle's speed in an urban area. The histogram is then approximated through a Gaussian-Mixture-Model. Given an appropriate number of Gaussians, which depends on a number of criteria that I discussed in section 3.3.2, each Gaussian in the GMM is transformed into a fuzzy set. These fuzzy sets have a clear semantic meaning and represent the driver's individual notion of the underlying physical concept, such as a *high Velocity*. This constitutes an improvement over other driver modeling methods based on fuzzy logic, which do not take the individual differences into account. In driver modeling, and even many other application areas, the fuzzy sets are usually defined based on expert knowledge, often through a trial and error process. The fuzzy variables that result from these methods provide only a limited validity for the modeling of the (individual) human reasoning process.

Based on the fuzzy variables and sample driving maneuvers extracted during regular driving, I developed a method in section 3.4 that generates a rulebase describing the driver's behavior with respect to the type of maneuver being modeled. In other approaches, the fuzzy rules are defined beforehand based on domain knowledge. The main problems with that approach are the difficulty of modeling all possible instances of a driving maneuver in advance and the lack of adaptation to the individual driving behavior. The key aspect of my method is the assessment of a rule's quality, which measures how good a rule is at characterizing the driving maneuver. From all possible rules extracted from the positive examples of a maneuver type, only those rules with a sufficiently high quality are kept in the rulebase, leading to a substantial reduction of its size. Since driving maneuvers are sequential in nature, I developed a fuzzy state machine based on these rules in section 3.5. This state machine uses the current state as well as sequences of previous rules leading to that state to infer the driver's intentions. The quality of a sequence of rules is calculated in an analogous manner to that of single rules. This quality is ultimately used as a predictor of the driver's intention to

execute the maneuver being modeled. Most other driver modeling methods, not only in the context of fuzzy logic, do not model the temporal development of a maneuver but only predict a maneuver based on data at any single point in time. The prediction accuracy can be improved by including the sequential nature of driving maneuvers in the model, as is done in this thesis.

I evaluated the performance of the driver model in chapter 4 with data collected in a field study. The study was conducted in the region around Braunschweig, Germany, with a research vehicle belonging to Volkswagen's Research Division. I presented the vehicular platform, information about the participants and the driving route as well as the kind of data recorded in the study in section 4.1. The aim of the field study was to collect data under natural driving conditions in order to build driver models representing the individual driving behavior with respect to two selected maneuver types.

In section 4.2 I generated driver models for the prediction of stopping maneuvers behind a leading vehicle. I chose this maneuver because it is a commonly occurring maneuver with a high relevance regarding vehicle safety. I identified relevant variables involved in the maneuver, extracted the respective data from the field study and generated fuzzy variables using the method described in section 3.3. For the construction of the rulebases and state machines I implemented an algorithm that extracts sample maneuvers from the data, which are then used as training examples. I used the Leave-one-out cross-validation method to evaluate the performance of the driver modeling method. The results showed that the models were able to predict all the maneuvers for more than half the participants, failing to predict just one sample maneuver for each of the remaining ones. The evaluation of the driver model showed that it fulfills the requirements real-time capability, sparing use of resources and traceability described in section 3.1.

The second maneuver that I investigated in section 4.3 was turning left at an intersection, which is another frequent maneuver in urban environments that can also cause critical situations. I chose the relevant variables, generated the fuzzy variables for those variables not already used for the prediction of stopping maneuvers and extracted turning maneuvers from the field study. The results of the cross-validation experiment were

6. CONCLUSION

very similar to those of predicting stopping maneuvers, showing the effectiveness of the method developed in this thesis.

The main purpose of the driver model is the driver-adaptive design of an advanced driver assistance system. I provided an example for such an adaptation in chapter 5. I chose the domain of Collision Avoidance / Collision Mitigation, because this is one area with high potential for improvement by driver-adaptive systems as I argued in sections 1.5 and 5.1. A second reason is the importance of these systems for car companies and society in general. Technologies from passive (airbags) and active (Collision Warning, ABS) safety have already reduced the effects of vehicle collisions substantially. Improving active safety systems can help reduce the number and severity of collisions even further, providing a considerable benefit for both the individual driver's safety and the prestige of the company offering that system.

To show the benefit of an adaptive CA / CM system, I developed a driver-adaptive autonomous braking algorithm in section 5.2. This algorithm is designed to perform an autonomous full brake if a leading vehicle brakes strongly and a number of additional requirements are met. I chose this scenario for its high practical relevance, supported by its prospective inclusion in the renowned EuroNCAP safety test. This approach deviates from those methods that concentrate on vehicle dynamics to assess the criticality of the situation. Due to the universality of that approach, much effectiveness is lost when considering specialized, well understood situations. The algorithm developed in this thesis on the other hand is based on detailed situation awareness, which includes knowledge about the target situation as well as the driver-dependent driving behavior. The algorithm is implemented as a fuzzy rulebase, which can easily be extended with rules describing other situations. The result is an autonomous braking algorithm that assists the driver in a driver-dependent way in a number of relevant critical scenarios.

In section 5.3 I evaluated the performance of the algorithm based on a simulator study. The results showed that the algorithm would have prevented or at least greatly reduced the severity of all collisions that occurred during the experiments. Due to the prediction of driving behavior and a driver-adaptive criticality measure, no incorrect or premature activation of the brake was observed. Hence, the system is able to provide vital assistance to the driver, without negative effects on consumer acceptance due to unexpected autonomous braking.

The current design of the driver model generates a new model from scratch each time a driver begins a new journey. This is necessary, because no information is available to identify the driver. If knowledge about the driver were available, the learning phase at the beginning of a journey could be reduced or even avoided altogether, if an efficient driver model for that driver had previously been generated. The identification of the driver would also enable the learning process to use data from various journeys, increasing the number of samples and hence the prediction accuracy. Driver models for the individual driver could be stored in the vehicle's memory, retrieved and optimized each time the driver performs a driving maneuver. The identification of the driver can be done in various ways, for instance through a driver-specific key, face recognition software or through observation of the driving behavior. A data-driven approach is conceptually most similar to the method I developed in this thesis and therefore of special interest. Some approaches have been attempted to identify the driver based on driving data ([124], [125]), the second also using Gaussian Mixture Models for the extraction of features. One of the next steps is to investigate if driver models generated from data where the driver is known can be used to identify that driver through his individual behavior. The results shown in Fig. 3.15 suggest that the driver models do vary significantly between drivers and could therefore be used to identify specific drivers.

A second approach how the driver model can be optimized is to find clusters of highly similar driving behavior. Instead of generating models for each driver separately, the goal is to find common behavior among drivers and use these clusters for the prediction of driving maneuvers. Clusters can be identified both for fuzzy variables and fuzzy state machines. The first identifies clusters of similar fuzzy variables, either by comparing the fuzzy variables themselves or the underlying histograms. The earth movers distance presented in section 3.3.1 could be used for that purpose. The second type of clusters is that of similar fuzzy state machines. The state machines for drivers with highly similar behavior for a given type of maneuvers could be merged to improve the generalization of the driver model. Such clusters, both for fuzzy variables and state machines, could be constructed not only depending on driving behavior, but also on environmental factors, such as bad weather or dense traffic conditions. Instead of generating new driver models on each occasion, the goal would be to identify those clusters that best describe the observed driving conditions. This has the advantage that the clusters can be generated

6. CONCLUSION

through a large-scale field study, evaluated by human experts and then integrated in a vehicle. This would guarantee a clearly defined behavior of the driver model, since, as opposed to the current models that are generated continuously while driving, it could have been carefully inspected and verified in advance before being included in a vehicle. To assess the practicality of the concept, a clustering method for fuzzy variables and fuzzy state machines will be developed and evaluated using the field study carried out in the course of this thesis.

List of Figures

1.1	Evolution of fatal accidents on Swedish roads	4
1.2	Subjective criticality of lane-change maneuvers	7
1.3	Kondo's driver model	9
1.4	Description of the car-following situation	10
1.5	Velocity profiles for a race course	17
1.6	Activation chain of a Collision Warning / Collision Mitigation system	20
2.1	The architecture of ACT-R	32
2.2	The DML framework	33
2.3	Gap acceptance in the DML framework	34
2.4	Taxonomy of neural networks	38
2.5	Example of a Bayesian network	40
2.6	Example of a Bayesian network for turn maneuver prediction	41
2.7	Example of a Hidden Markov Model	43
2.8	HMM for lane change recognition	44
2.9	Sub-HMM for lane change recognition	44
3.1	The fuzzy variable <i>Distance</i>	51
3.2	Example rule for the maneuver 'Stopping behind a vehicle'	52
3.3	Histogram for Relative Speed	55
3.4	Fuzzy set for <i>about zero</i>	56
3.5	Histogram of velocity in an urban environment	57
3.6	Histogram distances for velocity in an urban environment	58
3.7	Fuzzy sets for <i>medium Velocity</i> of two drivers based on percentiles	60
3.8	Histograms for velocity and yaw rate for one driver of the field study	61

LIST OF FIGURES

3.9	Adaptation of fuzzy sets	63
3.10	Histogram approximation by Gaussian Mixture Models	64
3.11	Histogram approximation by a Gaussian Mixture Model	65
3.12	Fuzzy sets based on a GMM with variations in σ	67
3.13	Fuzzy sets based on a GMM for the variable velocity	70
3.14	Fuzzy variable <i>Velocity</i>	73
3.15	Results of the preliminary study	74
3.16	The rule induction process	75
3.17	Sample fuzzy input variables for stopping maneuver prediction	76
3.18	Fuzzy output variable for stopping maneuver prediction	77
3.19	Sample data for a stopping maneuver	77
3.20	Harmonic mean of 5 variables	82
3.21	Sequence of states representing a stopping maneuver	85
3.22	State machine for stopping maneuver prediction	86
3.23	Stopping sequences for data point d_2	87
4.1	The test platform	90
4.2	Image taken by the vehicle's logging camera	91
4.3	Range and opening angles of the ARS 300	93
4.4	Driving route of the field study	94
4.5	Sample fuzzy variables for <i>Velocity</i>	97
4.6	Sample fuzzy variables for <i>Throttle</i>	98
4.7	Sample fuzzy variables for <i>Brake Pressure</i>	99
4.8	Sample fuzzy variables for <i>Time Headway</i>	100
4.9	Fuzzy variable for <i>Duration</i>	100
4.10	Sample stopping maneuver	103
4.11	Cross-validation results for stopping maneuver prediction models in the field study	106
4.12	Sample state machine for stopping maneuver prediction	111
4.13	Sample fuzzy variables for yaw rate	113
4.14	Fuzzy variable for distance to intersection	114
4.15	Fuzzy variable for left indicator	115
4.16	Sample left-turn maneuver	117

LIST OF FIGURES

4.17	Cross-validation results for turning maneuver prediction models in the field study	118
5.1	Activation times for a CA/CM system	122
5.2	Possible trajectories for collision avoidance	123
5.3	Accident causes for collisions involving lethal, heavy and light injuries .	125
5.4	Evaluation scenarios for CM systems	126
5.5	Fuzzy variable for situation criticality	128
5.6	flow chart of the autonomous braking algorithm	132
5.7	View of the driving simulator	133
5.8	Design of the simulator study	134
5.9	Fuzzy variables for situation criticality from the simulator study	137
5.10	Cross-validation results for stopping maneuver prediction in the simulator study	138
5.11	Sample collision scenario	143
B.1	Fuzzy variables for <i>Velocity</i> , drivers 1-12	166
B.2	Fuzzy variables for <i>Velocity</i> , drivers 13-26	166
B.3	Fuzzy variables for <i>Brake Pressure</i> , drivers 1-12	167
B.4	Fuzzy variables for <i>Brake Pressure</i> , drivers 13-26	167
B.5	Fuzzy variables for <i>Throttle</i> , drivers 1-12	168
B.6	Fuzzy variables for <i>Throttle</i> , drivers 13-26	168
B.7	Fuzzy variables for <i>Time Headway</i> , drivers 1-12	169
B.8	Fuzzy variables for <i>Time Headway</i> , drivers 13-26	169
B.9	Fuzzy variables for <i>Yaw Rate</i> , drivers 1-12	170
B.10	Fuzzy variables for <i>Yaw Rate</i> , drivers 13-26	170
C.1	Driver-dependent situation criticality, drivers 1-12	172
C.2	Driver-dependent situation criticality, drivers 13-26	172
D.1	Driver-dependent situation criticality (simulator study), drivers 1-10 . .	174
D.2	Driver-dependent situation criticality (simulator study), drivers 11-20 .	174

LIST OF FIGURES

List of Tables

1.1	Driver reaction in severe longitudinal collisions	25
2.1	Simple lists of driving maneuvers	28
4.1	Facts about the field study's participants	95
4.2	Fuzzy variables used for stopping maneuver prediction	102
4.3	Number of stopping maneuvers in the field study	104
4.4	Mean and standard deviation of prediction times	107
4.5	Mean size and its standard deviation of rulebases for stopping maneuver prediction	109
4.6	Mean size and standard deviation of rulebases containing rules of high belief for stopping maneuver prediction	110
4.7	Fuzzy variables used for turning maneuver prediction	115
4.8	Number of turning maneuvers in the field study	118
4.9	Mean size and standard deviation of rulebases for left-turn maneuver prediction	119
4.10	Mean size and standard deviation of rulebases containing rules of high belief for left-turn maneuver prediction	120
5.1	Number of longitudinal scenarios in the simulator study	135
5.2	Number of stopping maneuvers in the simulator study	136
5.3	Analysis of critical situations in the simulator study	140
5.4	Effectiveness of the autonomous braking algorithm	142

References

- [1] STATISTISCHES BUNDESAMT. **Verkehrsunfälle 2003**, 2005. 4
- [2] C WIACEK. **Characteristics in Rear-End-Crashes**. 1999. 5, 24, 25
- [3] V. L. NEALE, T. A. DINGUS, S. G. KLAUER, J. SUDWEEKS, AND M. GOODMAN. **An Overview of the 100-Car Naturalistic Study and Findings**. Technical report, National Highway Traffic Safety Administration and Virginia Tech Transportation Institute, 2005. 6
- [4] H. WINNER, S. HAKULI, AND G. WOLF. *Handbuch Fahrerassistenzsysteme. Grundlagen, Komponenten und Systeme für aktive Sicherheit*. Vieweg+Teubner, 2009. 6, 7, 122
- [5] T. JÜRGENSOHN. *Hybride Fahrermodelle*. BWV - Berliner Wissenschafts-Verlag, 1997. 8, 16, 17, 30
- [6] M. PLOECHL AND J. EDELMANN. **Driver models in automobile dynamics application**. *Vehicle System Dynamics*, **45**(7-8):699/741, 2007. 8, 9, 14
- [7] M. KONDO. **Directional stability (when steering is added)**. *Journal of the Society of Automotive Engineers of Japan (JSAE)*, **7**:5-6, 1953. 9
- [8] J. BENGTSOHN. *Adaptive Cruise Control and Driver Modeling*. PhD thesis, Lund Institute of Technology, 2001. 10
- [9] R. E. CHANDLER, R. HERMAN, AND E. MONTROLL. **Traffic dynamics: studies in car following**. *Operation Research*, **6**, 1958. 10, 13, 14
- [10] D. C. GAZIS, R. HERMAN, AND B. POTTS. **Car-following theory of steady-state traffic flow**. *Operation Research*, **7**:499-505, 1959. 10
- [11] D. C. GAZIS, R. HERMAN, AND B. POTTS. **Nonlinear follow-the-leader models of traffic flow**. *Operation Research*, **9**:545-567, 1961. 11
- [12] W. LEUTZBACH. *Introduction to the Theory of Traffic Flow*. Springer Verlag, 1968. 11
- [13] W. LEUTZBACH AND R. WIEDEMANN. **Development and applications of traffic simulation models at the Karlsruhe Institut für Verkehrswesen**. *Traffic Engineering and Control*, page 270278, 1986. 11
- [14] M. BRACKSTONE, B. SULTAN, AND M. McDONALD. **Motorway driver behavior: studies on car following**. *Transportation Research Part F*, **5**:3146, 2002. 11
- [15] P. FANCHER, R. ERVIN, J. SAYER, M. HAGAN, S. BOGARD, Z. BAREKET, M. MEFFORD, AND J. HAUGEN. **Intelligent cruise control field operational test. Final report. Volume I: Technical report**. Technical report, University of Michigan, Ann Arbor, 1998. 11, 13
- [16] M. APETAUR AND F. OPICKA. **Assessment of the driver's effort in typical driving manoeuvres for different vehicle configurations and managements**. *Vehicle System Dynamics Supplement*, **20**:42-56, 1991. 12
- [17] H. OHNO. **Analysis and modeling of human driving behaviors using adaptive cruise control**. In *26th Annual Conference of the IEEE Industrial Electronics Society*, **4**, pages 2803-2808, 2000. 12
- [18] S. WRIGHT, T. FERNANDO, N. WARD, AND A. COHN. **A Framework for Supporting Intelligent Traffic Within the Leeds Driving Simulator**. *ECAI 98 Workshop on Intelligent Virtual Environments*, 1998. 13, 30
- [19] B.S. KERNER AND S.L. KLENOV. **Deterministic microscopic three-phase traffic flow models**. *Journal of Physics A: mathematical and general*, **39**(8):1775-1809, 2006. 13
- [20] J. VANDERWERF, S. SHLADOVER, N. KOURJANSKAIA, M. MILLER, AND H. KRISHNAN. **Modeling Effects of Driver Control Assistance Systems on Traffic**. *Transportation Research Record: Journal of the Transportation Research Board*, **1748**(2001):167-174, 2007. 13
- [21] Z. BAREKET, P.S. FANCHER, H. PENG, AND K. LEE. **Methodology for assessing adaptive cruise control behavior**. *IEEE Transactions on Intelligent Transportation Systems*, **4**(3):123-131, 2003. 13
- [22] P. A. IOANNOU AND C. C. CHEN. **Autonomous intelligent cruise control**. *IEEE Transactions on Vehicular Technology*, **42**(4), 1993. 14
- [23] S. GERMANN AND R. ISERMANN. **Nonlinear distance and cruise control for passenger cars**. *Proceedings of the American Control Conference*, 1:30813085, 1995. 14
- [24] J. SCHMITT AND B. FÄRBER. **Verbesserung von FAS durch Fahrerabsichtserkennung mit Fuzzy Logic**. *VDI Berichte*, **1919**:177-186, 2005. 14, 45, 129
- [25] J. SCHMITT, A. BREU, M. MAURER, AND B. FÄRBER. **Simulation des Bremsverhaltens in Gefahrensituationen mittels experimentell validiertem Fahrermodell**. *VDI Berichte*, **2015**:75-88, 2007. 14
- [26] J.C. MCCALL, D. P. WIPF, M. M. TRIVEDI, , AND B. D. RAO. **Lane Change Intent Analysis Using Robust Operators and Sparse Bayesian Learning**. In *IEEE Transactions on Intelligent Transportation Systems*, **8**, pages 431-440, 2007. 14
- [27] N. KUGE, T. YAMAMURA, O. SHIMOYAMA, AND A. LIU. **A driver behavior recognition method based on a driver model framework**. In *Proceedings of the 2000 SAE World Congress*, 2000. 14, 44
- [28] S. Y. CHENG AND M. M. TRIVEDI. **Turn-Intent Analysis Using Body Pose for Intelligent Driver Assistance**. *Pervasive Computing*, **5**(4):28-37, 2006. 14

REFERENCES

- [29] H. BERNDT AND K. DIETMAYER. **Driver intention inference with vehicle onboard sensors.** In *IEEE International Conference on Vehicular Electronics and Safety*, pages 102–107, 2009. 14, 45
- [30] L. M. BERGASA, J. NUEVO, M. A. SOTELO, R. BAREA, AND M. E. LOPEZ. **Real-Time System for Monitoring Driver Vigilance.** *IEEE Transaction on Intelligent Transportation Systems*, **7**(1):63–77, 2006. 15
- [31] Y. NOGUSHI, R. NOPSUWANCHAI, M. OHSUGA, AND Y. KAMAKURA. **Classification of Blink Waveforms Towards the Assessment of Drivers Arousal Level An Approach for HMM Based Classification from Blinking Video Sequence.** *LNCS*, **4562**:779–786, 2007. 15
- [32] Q. JI, Z. ZHIWEI, AND P. LAN. **Real Time Non-intrusive Monitoring and Prediction of Driver Fatigue.** *IEEE Transactions on Vehicular Technology*, **53**(4):1052–1068, 2004. 15
- [33] S. DENG, X. XU, X. YANG, AND D. MIAO. **Research on the driver fatigue monitoring method based on the Dempster-Shafer theory.** *Chinese Control and Decision Conference*, pages 4176–4179, 2010. 15
- [34] S. JIN, S.-Y. PARK, AND J.-J. LEE. **Driver fatigue detection using a genetic algorithm.** *Artificial Life and Robotics*, **11**:87–90, 2007. 15
- [35] D. SANDBERG AND M. WAHDE. **Particle swarm optimization of feedforward neural networks for the detection of drowsy driving.** *IEEE International Joint Conference on Neural Networks*, pages 788–793, 2008. 15
- [36] T. DORAZIO, M. LEO, C. GUARAGNELLA, AND A. DISTANTE. **A visual approach for driver inattention detection.** *Pattern Recognition*, **40**(8):2341–2355, 2007. 15
- [37] P. SMITH, M. SHAH, AND N. DA VITORIA LOBO. **Determining Driver Visual Attention With One Camera.** *IEEE Transactions on Intelligent Transport Systems*, **4**(4):205–218, 2003. 15
- [38] M. KUTILA, M. JOKELA, T. MÄKINEN, J. VIITANEN, G. MARKKULA, AND T. W. VICTOR. **Driver cognitive distraction detection: feature estimation and implementation.** *Proceedings of the Institution of Mechanical Engineers, Part D: Journal of Automobile Engineering*, **221**(9):1027–1040, 2007. 15
- [39] D. D. SALVUCCI AND K. L. MACUGA. **Predicting the effects of cellular-phone dialing on driver performance.** *Cognitive Systems Research*, **3**:95–102, 2002. 15, 35
- [40] F. TANGO, L. MININ, F. TESAURI, AND R. MONTANARI. **Field tests and machine learning approaches for refining algorithms and correlations of drivers model parameters.** *Applied Ergonomics*, **41**(2):2211–2224, 2010. 15
- [41] J. A. HEALEY AND R. W. PICARD. **Detecting Stress During Real-World Driving Tasks Using Physiological Sensors.** *IEEE Transactions on Intelligent Transportation Systems*, **6**(2):156–166, 2005. 15
- [42] T. YAMAKOSHI, K. YAMAKOSHI, S. TANAKA, M. NOGAWA, M. SHIBATA, Y. SAWADA, P. ROLFE, AND Y. HIROSE. **A Preliminary Study on Driver’s Stress Index Using a New Method Based on Differential Skin Temperature Measurement.** In *Proceedings of the 29th Annual International Conference of the IEEE Engineering in Medicine and Biology Society*, pages 722–725, 2007. 15
- [43] M. GRIMM, K. KROSCHEL, H. HARRIS, C. NASS, B. SCHULLER, G. RIGOLL, AND T. MOOSMAYR. **On the Necessity and Feasibility of Detecting a Driver’s Emotional State While Driving.** In A. PAVIA, R. PRADA, AND R. W. PICARD, editors, *Lecture Notes on Computer Science*, **4738**, pages 126–138. Springer, 2007. 15
- [44] C. M. JONES AND I.-M. JONSSON. **Performance Analysis of Acoustic Emotion Recognition for In-Car Conversational Interfaces.** In C. STEPHANIDIS, editor, *Lecture Notes in Compute Science*, **4555**, pages 411–420. Springer, 2007. 15
- [45] ZHENLONG L. AND W. XIAOXIA. **Emotion modeling of the driver based on fuzzy logic.** *12th International IEEE Conference on Intelligent Transportation Systems*, pages 1–5, 2009. 15
- [46] J. KRUMM. **A Markov Model for Driver Turn Prediction.** *Society of Automotive Engineers (SAE) World Congress*, 2008. 16, 17
- [47] R. SIMMONS, B. BROWNING, Y. ZHANG, AND V. SADEKAR. **Learning to Predict Driver Route and Destination Intent.** *Proceedings of the 2006 IEEE Intelligent Transportation Systems Conference*, pages 127–132, 2006. 16, 17
- [48] J. A. MICHON. **A Critical View of Driver Behaviour Models: What Do We Know, What Should We Do?** In L. EVANS & R. C. SCHWING, editor, *Human Behaviour and Traffic Safety*, pages 485–520. Plenum Press, 1985. 16, 49
- [49] G. REICHHART. *Menschliche Zuverlässigkeit beim Führen von Kraftfahrzeugen.* VDI-Verlag, 2001. 27, 28
- [50] W. TÖLLE. *Ein Fahrmanöverkonzept für einen maschinellen Kopiloten.* PhD thesis, Universität Karlsruhe, 1996. 27, 28
- [51] A. OKUNO, K. FUJITA, AND A. KUTAMI. *Vision-based vehicle guidance*, chapter Visual navigation of an autonomous on-road vehicle: autonomous cruising on highways, pages 222–237. Springer-Verlag New York, New York, NY, USA, 1992. 28
- [52] W. FASTENMEIER. *Autofahrer und Verkehrssituation.* Verlag TÜV Rheinland, 1995. 28
- [53] HELGA VON BENDA. **Häufigkeit von Verkehrssituationen.** Technical report, Bundesanstalt für Straßenwesen Bereich Unfallforschung, Bergisch Gladbach, 1985. 28
- [54] U. KIENCKE, R. MAJJAD, AND S. KRAMER. **Modeling and performance analysis of a hybrid driver model.** *Control Engineering Practice*, **7**(8):985 – 991, 1999. 31, 36
- [55] A. NEWELL. *Unified theories of cognition.* Harvard University Press, 1990. 31

REFERENCES

- [56] J. R. ANDERSON AND C. LEBIERE. *The atomic components of thought*. Erlbaum, 1998. 31
- [57] J. CAO AND H. WANG. **Vision navigation for driver cognitive model in ACT-R architecture**. *9th IEEE International Conference on Cognitive Informatics*, pages 946 – 951, 2010. 32
- [58] N.E. ABSIL AND J. PAUWELUSSEN. **Driver Model Library**. *IEEE International Conference on Systems Man and Cybernetics*, pages 1293–1299, 2010. 33, 34
- [59] O. SELFRIDGE. **Pandemonium: a paradigm for learning. Mechanism of Thought Processes**. *Proceedings of a Symposium Held at the National Physical Laboratory, London*, pages 513–526, 1958. 33
- [60] M. BAUMANN AND J. K. KREMS. **A Comprehension Based Cognitive Model of Situation Awareness**. *Digital Human Modeling*, pages 192–201, 2009. 35
- [61] J. ANDERSON, L. M. REDER, AND C. LEBIERE. **Working Memory: Activation Limitations on Retrieval**. *Cognitive Psychology*, **30**:221256, 1996. 35
- [62] J. AASMAN. *Modelling driver behaviour in Soar*. PhD thesis, University of Groningen, 1995. 35
- [63] D.D. SALVUCCI. **Modeling Driver Behavior in a Cognitive Architecture**. *HUMAN FACTORS*, **48**(2):362380, 2006. 35
- [64] B. SONG, D. DELORME, AND J. VADERWERF. **Cognitive and hybrid model of human driver**. *Proceedings of the Intelligent Vehicles Symposium*, pages 1–6, 2000. 35
- [65] A.K. JAIN, J. MAO, AND K. MOHIUDDIN. **Artificial Neural Networks: A Tutorial**. *IEEE Computer*, **29**:31–44, 1996. 38
- [66] CH. C. MACADAM AND G.E. JOHNSON. **Application of elementary neural networks and preview sensors for representing driver steering control behavior**. *Vehicle System Dynamics*, **25**:3–30, 1996. 38
- [67] K.F. KRAISS AND H. KÜTTELWESCH. **Identification and application of neural operator models in car driving situation**. *Proceedings of the Fifth IFAC/IFIP/IFORS/IEA Symposium on Analysis, Design and Evaluation of Man-Machine-Systems*, pages 121–126, 1992. 38
- [68] U. DOGAN, H. EDELBRUNNER, AND I. IOSSIFIDIS. **Towards a Driver Model: Preliminary Study of Lane Change Behavior**. *Proceedings of the 11th International IEEE Conference on Intelligent Transportation Systems*, pages 931–937, 2008. 38
- [69] D. MITROVIC. **Machine Learning for Car Navigation**. *Lecture Notes in Computer Science*, **2070**:670–675, 2001. 38
- [70] G.A. ZADEH, A. FAHIM, AND M. EL-GINDY. **Neural networks and fuzzy logic applications to vehicle systems: literature survey**. *International Journal of Vehicle Design*, **18**(2):132–193, 1997. 38
- [71] I. BEN-GAL. **Bayesian Networks**. In RUGGERI F., FALTIN F., AND KENETT R., editors, *Encyclopedia of Statistics in Quality and Reliability*. John Wiley & Sons, 2007. 39, 40
- [72] C. KUTZERA. *Fahrerintentionsschätzung für Stadtassistentensysteme*. Master’s thesis, Hochschule Mannheim, 2008. 40, 41
- [73] S. TEZUKA, T. SOMA, AND K. TANIFUJ. **A Study of Driver Behavior Inference Model at Time of Lane Change using Bayesian Networks**. *Proceedings of the 2006 IEEE International Conference on Industrial Technology*, pages 2308–2313, 2006. 41
- [74] H. AMATA, C. MIYAJIMA, AND T. ET AL. NISHINO. **Prediction Model of Driving Behavior Based Traffic Conditions and Driver Types**. *IEEE Int. Conf. on Intelligent Transportation Systems*, pages 747–752, 2009. 41
- [75] F. KLANNER. *Entwicklung eines kommunikationsbasierten Querverkehrsassistenten im Fahrzeug*. PhD thesis, Technische Universität Darmstadt, 2008. 41
- [76] N. OLIVER AND A. P. PENTLAND. **Graphical Models for Driver Behavior Recognition in a SmartCar**. In *IEEE Intl. Conference on Intelligent Vehicles*, pages 7–12, 2000. 45
- [77] D. POLLING, M. MULDER, M. M. VAN PAASSEN, AND Q. P. CHU. **Inferring the drivers lane change intention using context-based dynamic Bayesian networks**. *Proceedings of the 2005 IEEE International Conference on Systems, Man, and Cybernetics*, 1:853–858, 2005. 45
- [78] T. KUMAGAI, Y. SAKAGUCHI, M. OKUWA, AND M. AKAMATSU. **Prediction of Driving Behavior through Probabilistic Inference**. In *International Conference on Engineering Applications of Neural Networks*, **8**, pages 8–10, 2003. 45
- [79] S.-T. LI, L.-S. GUO, H. XU, C. ZONG, AND R.-K. SHI. **Drivers’ braking intentions identification of EHB system based on fuzzy logic**. *International Conference on Machine Learning and Cybernetics*, 1:619 – 624, 2009. 46
- [80] C. BLASCHKE, J. SCHMITT, AND FÄRBER B. **Fahrmanöver-Prädiktion über CAN-Bus Daten**. In *Fahrer im 21. Jahrhundert -Human Machine Interface*, pages 165–177. VDI, 2007. 46
- [81] K. OHASHI, T. YAMAGUCHI, AND I. TAMAI. **Humane Automotive System Using Driver Intention Recognition**. *Annual SICE Conference*, **2**:1164–1167, 2004. 46
- [82] A. KHODAYARI, R. KAZEMI, A. GHAFARI, AND R. BRAUNSTINGL. **Design of an improved fuzzy logic based model for prediction of car following behavior**. *IEEE International Conference on Mechatronics*, pages 200 – 205, 2011. 46
- [83] L. ZADEH. **Fuzzy Sets**. *Information and Control*, **8**(3):338–353, 1965. 50
- [84] W. PEDRYCZ AND F. GOMIDE. *Fuzzy Systems Engineering: Toward Human-Centric Computing*. Wiley-IEEE Press, 2007. 51, 62
- [85] G. KLIR AND B. YUAN. *Fuzzy Sets and Fuzzy Logic: Theory and Applications*. Prentice Hall PTR, 1995. 53, 67

REFERENCES

- [86] O. CASTILLO AND P. MELIN. *Type-2 Fuzzy Logic: Theory and Applications*. Springer, 2008. 53
- [87] L. RUTKOWSKI. *Flexible Neuro-Fuzzy Systems: Structures, Learning and Performance Evaluation*. Kluwer Academic Publishers, 2004. 53
- [88] E. LUGHOFFER. *Evolving Fuzzy Systems Methodologies, Advanced Concepts and Applications*. Springer, 2011. 53
- [89] T. J. AYRES, L. LI, D. SCHLEUNING, AND D. YOUNG. **Preferred time-headway of highway drivers**. *Intelligent Transportation Systems, 2001. Proceedings. 2001 IEEE*, pages 826–829, August 2002. 53
- [90] J. WANG, M. LU, AND K. LI. **Characterization of Longitudinal Driving Behavior by Measurable Parameters**. *Transportation Research Record: Journal of the Transportation Research Board*, **2185**:15–23, 2011. 54
- [91] J. WU, M. BRACKSTONE, AND M. McDONALD. **Fuzzy sets and systems for a motorway microscopic simulation model**. *Fuzzy Sets and Systems*, **116**(1):65 – 76, 2000. 54, 55, 56, 69, 73
- [92] F.J. AHERNE, N.A. THACKER, AND P. ROCKETT. **The Bhat-tacharyya Metric as an Absolute Similarity Measure for Frequency Coded Data**. *Kybernetika*, **34**(4):363–368, 1998. 57
- [93] YOSSI RUBNER, CARLO TOMASI, AND LEONIDAS J. GUIBAS. **The earth movers distance as a metric for image retrieval**. *International Journal of Computer Vision*, **40**:2000, 2000. 57
- [94] JEFF A. BILMES. **A gentle tutorial on the EM algorithm and its application to parameter estimation for gaussian mixture and hidden markov models**. Technical report, U.C. Berkeley, 1998. 60
- [95] A. TENZER. **Die Fahrerleistungsdatenbank der Volkswagen AG als Werkzeug zur Beobachtung von Fahrerverhalten**. In *21. VW/VDI-Gemeinschaftstagung "Integrierte Sicherheit und Fahrerassistenzsysteme"*, 2004. 60, 74, 94
- [96] C. BAUER, M. GONTER, AND R. ROJAS. **Fahrerspezifische Prädiktion von Fahrmanövern mit Fuzzy Logic**. *3. Fachtagung Fahrermodellierung*, 2010. 60
- [97] JYH SHING ROGER JANG. **ANFIS: Adaptive-Network-Based Fuzzy Inference System**. *IEEE Transactions on Systems, Man, and Cybernetics*, **23**:665–685, 1993. 63
- [98] R. YAGER. **Entropy and specificity in a mathematical theory of evidence**. *Int. J. Gen. Syst.*, **9**:249–260, 1983. 69
- [99] J. E. NARANJO, C. GONZÁLEZ, R. GARCÍA, AND T. DE PEDRO. **ACC+Stop&Go Maneuvers With Throttle and Brake Fuzzy Control**. In *IEEE Transactions on Intelligent Transportation Systems*, **7**, pages 213–225, 2006. 73
- [100] R. HOLVE AND P. PROTZEL. **Adaptive Fuzzy Control for Driver Assistance in Car-Following**. In *3rd European Congress on Intelligent Techniques and Soft Computing*, pages 1149 – 1153, 1995. 73, 74
- [101] C. BAUER, M. GONTER, AND R. ROJAS. **Fahrerspezifische Analyse des Fahrverhaltens zur Parametrierung aktiver Sicherheitssysteme**. *Sicherheit durch Fahrerassistenz*, 2010. 73, 74
- [102] R. HOLVE AND P. PROTZEL. **Generating Fuzzy Rules for the Acceleration Control of an Adaptive Cruise Control System**. *NAFIPS*, 1995. 75
- [103] EARL COX. *Fuzzy Modeling and Genetic Algorithms for Data Mining and Exploration (The Morgan Kaufmann Series in Data Management Systems)*. Morgan Kaufmann, 2005. 75
- [104] P. HELD. *Schätzen verdeckter Fahrereigenschaften auf Basis des Fahrverhaltens*. Master's thesis, Otto-von-Guericke-Universität Magdeburg, 2011. 89
- [105] N. KAEMPCHEN, B. SCHIELE, AND K. DIETMAYER. **Situation Assessment of an Autonomous Emergency Brake for Arbitrary Vehicle-to-Vehicle Collision Scenarios**. *IEEE Transactions on Intelligent Transportation Systems*, **10**:678 – 687, 2009. 122, 123, 139
- [106] S. KOPISCHKE. *Entwicklung einer Notbremsfunktion mit Rapid Prototyping Methoden*. PhD thesis, TU Braunschweig, 2000. 123, 139
- [107] M. BRÄNNSTRÖM, E. COELINGH, AND J. SJÖBERG. **Model-Based Threat Assessment for Avoiding Arbitrary Vehicle Collisions**. In *IEEE Transactions on Intelligent Transportation Systems*, **11**, pages 658 – 669, 2010. 123
- [108] R. LABAYRADE, C. ROYERE, AND D. AUBERT. **A collision mitigation system using laser scanner and stereovision fusion and its assessment**. In *IEEE Intelligent Vehicles Symposium*, pages 441–446, 2005. 123, 127
- [109] Y. ZHANG, E.K. ANTONSSON, AND K. GROTE. **A new threat assessment measure for collision avoidance systems**. *IEEE Intelligent Transportation Systems Conference*, pages 968 – 975, 2006. 124
- [110] A. SEECK. **Bewertung von aktiver/integrierter Sicherheit für Euro NCAP**. *Kooperationsforum Fahrerassistenzsysteme*, 2011. 125, 126
- [111] T.-Y. SUN, S.-J. TSAI, J.-Y. TSENG, AND Y.-C. TSENG. **The study on intelligent vehicle collision-avoidance system with vision perception and fuzzy decision making**. In *IEEE Intelligent Vehicles Symposium*, pages 112–117, 2005. 127
- [112] M. M. MINDERHOUD AND P. H. L. BOVY. **Extended time-to-collision measures for road traffic safety assessment**. *Accident Analysis & Prevention*, **33**(1):89 – 97, 2001. 127
- [113] R. VAN DER HORST. *A time-based analysis of road user behavior in normal and critical encounters*. PhD thesis, Delft University of Technology, 1990. 127
- [114] Å. SVENSSON. *A method for analysing the traffic process in a safety perspective*. PhD thesis, University of Lund, 1998. 127, 131
- [115] K. VOGEL. **A comparison of headway and time to collision as safety indicators**. *Accident Analysis & Prevention*, **35**(3):427 – 433, 2003. 127, 128

REFERENCES

- [116] J. C. MCCALL AND M. TRIVEDI. **Driver Behavior and Situation Aware Brake Assistance for Intelligent Vehicles.** In *Proceedings of the IEEE*, **95**, pages 374 – 387, Feb. 2007. 127, 130
- [117] A. EIDEHALL AND L. PETERSSON. **Statistical Threat Assessment for General Road Scenes Using Monte Carlo Sampling.** *IEEE Transactions on Intelligent Transportation Systems*, **9**:137 – 147, 2008. 127
- [118] M.A.S. KAMAL, T. KAWABE, J. MURATA, AND M. MUKAI. **Driver-Adaptive Assist System for Avoiding Abnormality in Driving.** In *International Conference on Control Applications*, pages 1247 – 1252, 2007. 129
- [119] T. POITSCHKE, F. LAQUAI, AND G. RIGOLL. **Agent-Based Driver Abnormality Estimation.** In *Proceedings of the 13th International Conference on Human-Computer Interaction. Part III: Ubiquitous and Intelligent Interaction.* Springer-Verlag, 2009. 129
- [120] T. WADA, S. DOI, N. TSURU, K. ISAJI, AND H. KANEKO. **Characterization of Expert Drivers Last-Second Braking and Its Application to a Collision Avoidance System.** *IEEE Transactions on Intelligent Transportation Systems*, **2**:413–422, 2010. 129
- [121] N. GKIKAS, J. HILL, AND J. RICHARDSON. **Exploitable characteristics of driver braking.** *Proceedings of the 21st International Technical Conference on the Enhanced Safety of Vehicles [ESV]*, 2009. 129
- [122] M. ALONSO, M. VEGA, AND O. MARTN. **Driving simulation study for the analysis of distraction effects in longitudinal driving behaviour.** *Cognition, Technology & Work*, pages 1–15, 2011. 10.1007/s10111-011-0180-9. 130
- [123] P. COOPER. **Turning gap acceptance decision-making: the impact of driver distraction.** *Journal of Safety Research*, **33**:312–335, 2002. 130
- [124] J. BERGHOLZ, O. PION, R. HENZE, H. KOLLMER, AND F. KÜÇÜKAY. **Fingerprint des Fahrers zur Adaption von Assistenzsystemen.** *Gemeinschaftstagung Fahrerassistenz und Integrierte Sicherheit*, **26**, 2011. 149
- [125] C. MIYAJIMA, Y. NISHIWAKI, K. OZAWA, T. WAKITA, K. ITOU, K. TAKEDA, AND F. ITAKURA. **Driver Modeling Based on Driving Behavior and Its Evaluation in Driver Identification.** *Proceedings of the IEEE*, **95**(2):427–437, 2007. 149

Erklärung

Hiermit versichere ich, für die Erstellung dieser Arbeit alle Hilfsmittel und Hilfen angegeben, und die Arbeit auf dieser Grundlage selbständig verfasst zu haben. Weiterhin versichere ich, dass die Arbeit noch nicht in einem früheren Promotionsverfahren in identischer oder ähnlicher Form eingereicht wurde.

Berlin, den 13.12.2011

Colin Bauer

REFERENCES

Appendix A

Zusammenfassung

Diese Arbeit beschreibt eine Methode der fahrerabhängigen Vorhersage von Fahrmanövern. Die Methode erstellt ein Modell des Fahrverhaltens anhand von während der Fahrt beobachteten Daten. Der Ansatz basiert auf Fuzzy Logik, einer Theory, die eine an die menschliche Denkweise angelehnte Form des logischen Schließens ermöglicht. Nach einer Lernphase ist das Modell in der Lage, neue Instanzen eines Fahrmanövers vorherzusagen. Diese Information kann genutzt werden, um Fahrerassistenzsysteme an die individuelle Fahrweise anzupassen. Diese Dissertation enthält drei bedeutende Beiträge. Der erste ist die fahrerabhängige Erstellung von Fuzzy Variablen. Eine Methode wurde entwickelt, die ein Histogramm durch ein Gaussian-Mixture-Modell approximiert und dieses in eine Fuzzy Variable verwandelt. Die auf diese Weise erstellten Fuzzy Variablen teilen gewünschte Größen, etwa die Fahrzeuggeschwindigkeit, in Fuzzy Sets mit einer wohldefinierten und fahrerspezifischen semantischen Bedeutung ein. Der zweite Beitrag betrifft die Generierung von fahrerabhängigen Zustandsautomaten aus Beispielmanövern, welche die sequentielle Natur von Fahrmanövern beschreiben. Ein Qualitätsmaß wurde entwickelt, das die Güte der Zustände und Zustandssequenzen bewertet, wodurch der Zustandsautomat optimiert werden kann. Das Ergebnis ist eine präzise und nachvollziehbare Darstellung des individuellen Fahrverhaltens. Der dritte Beitrag bezieht sich auf die Entwicklung eines fahrerindividuellen und situationsspezifischen autonomen Notbremsalgorithmus. Der Algorithmus löst eine autonome Notbremsung in einer spezifischen kritischen Situation aus und berücksichtigt in dem Entscheidungsprozess die Vorhersage des individuellen Fahrverhaltens. Es konnte anhand einer Simulationsstudie gezeigt werden, dass der Algorithmus Kollisionen in diesem Szenario vermeiden kann, ohne dabei auch in für den Fahrer beherrschbaren Situationen eine frühzeitige Bremsung einzuleiten, und somit dem Fahrer eine wertvolle Unterstützung bietet.

A. ZUSAMMENFASSUNG

Appendix B

Fuzzy variables of the field study

Those fuzzy variables used in the prediction of driving maneuvers that are driver-adaptive are depicted here for all 26 drivers of the field study . The variables are

- Velocity
- Brake Pressure
- Throttle
- Time Headway
- Yaw Rate

B. FUZZY VARIABLES OF THE FIELD STUDY

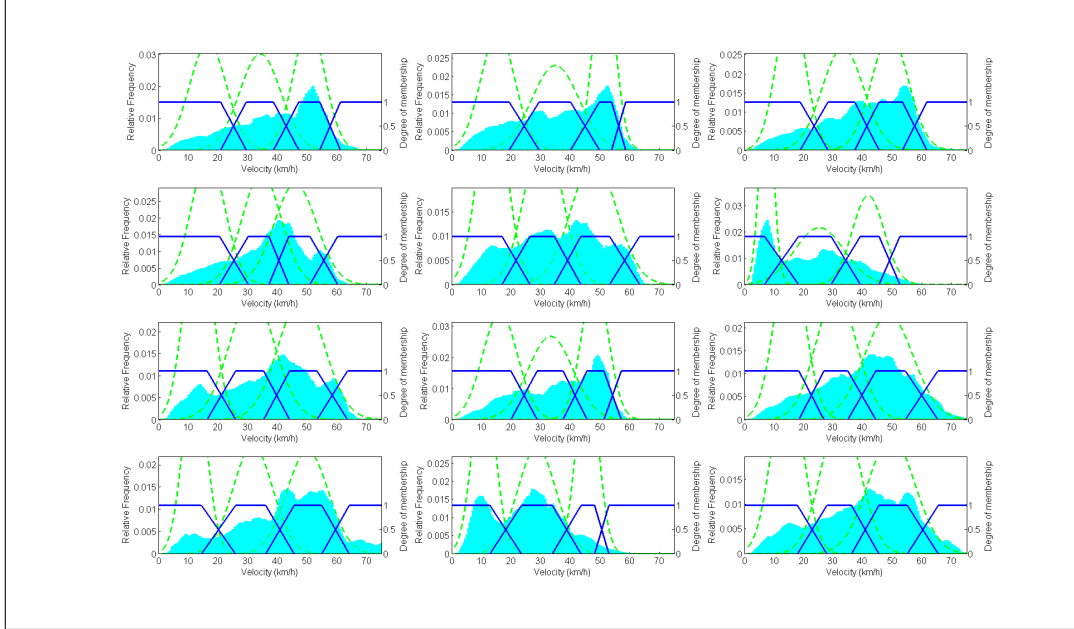

Figure B.1: Fuzzy variables for *Velocity*, drivers 1-12

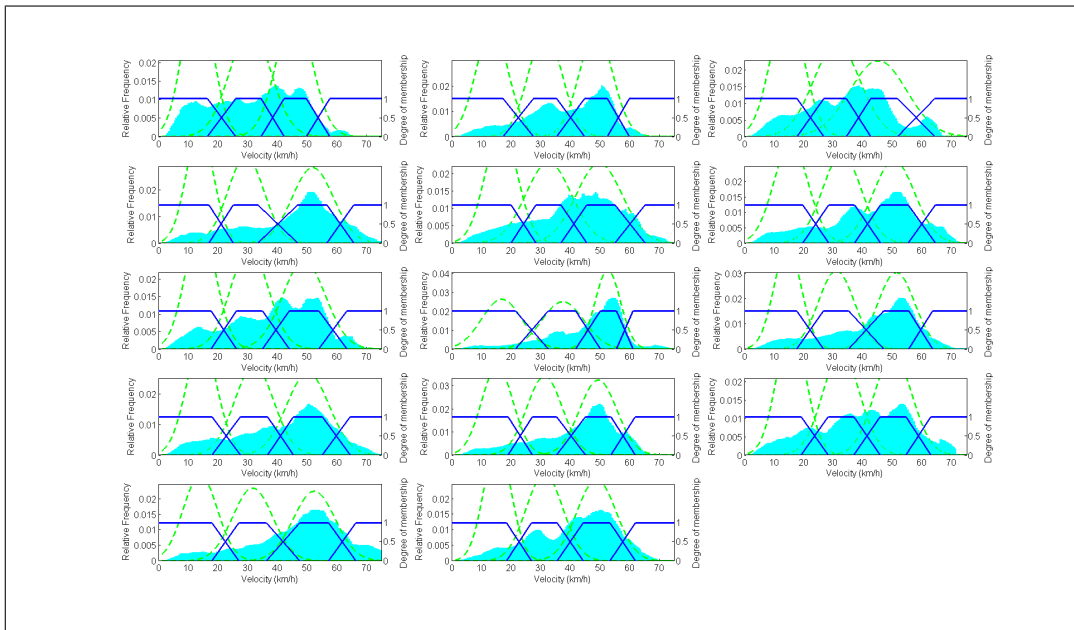

Figure B.2: Fuzzy variables for *Velocity*, drivers 13-26

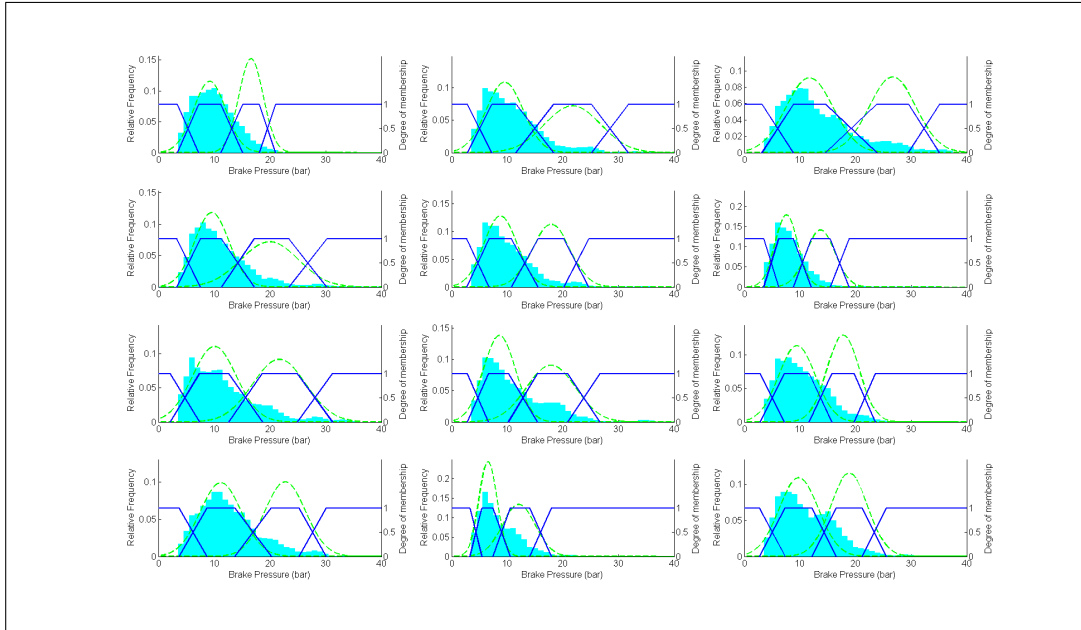

Figure B.3: Fuzzy variables for *Brake Pressure*, drivers 1-12

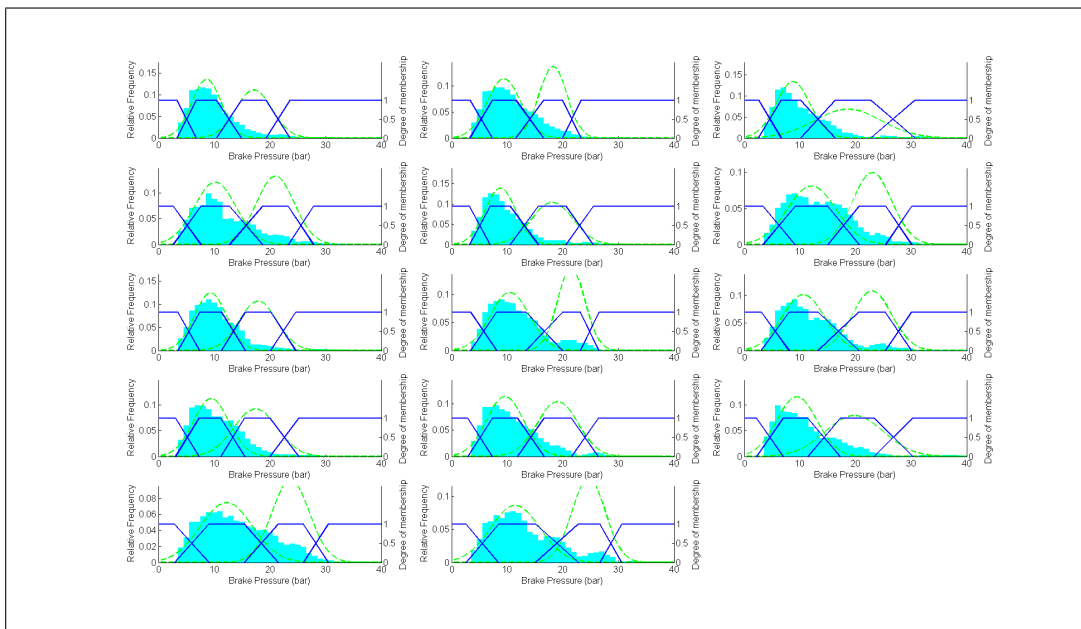

Figure B.4: Fuzzy variables for *Brake Pressure*, drivers 13-26

B. FUZZY VARIABLES OF THE FIELD STUDY

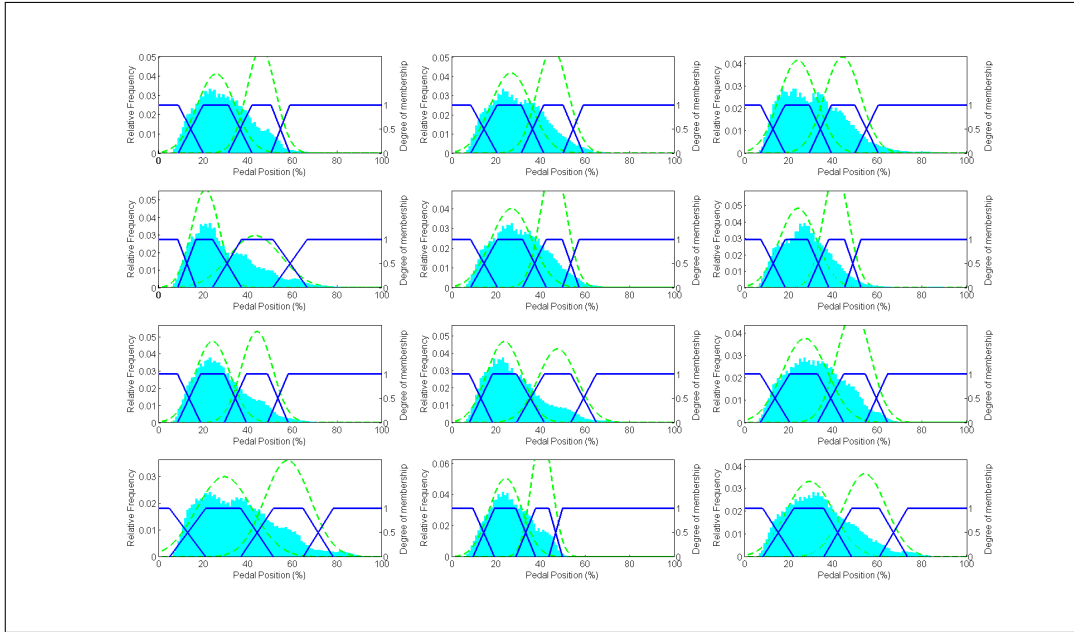

Figure B.5: Fuzzy variables for *Throttle*, drivers 1-12

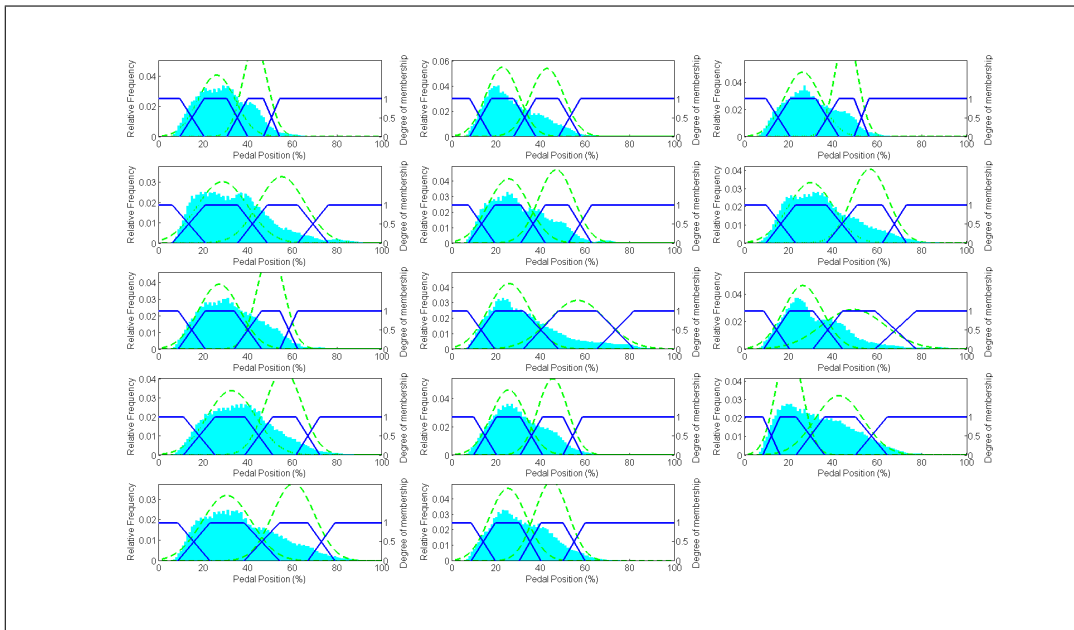

Figure B.6: Fuzzy variables for *Throttle*, drivers 13-26

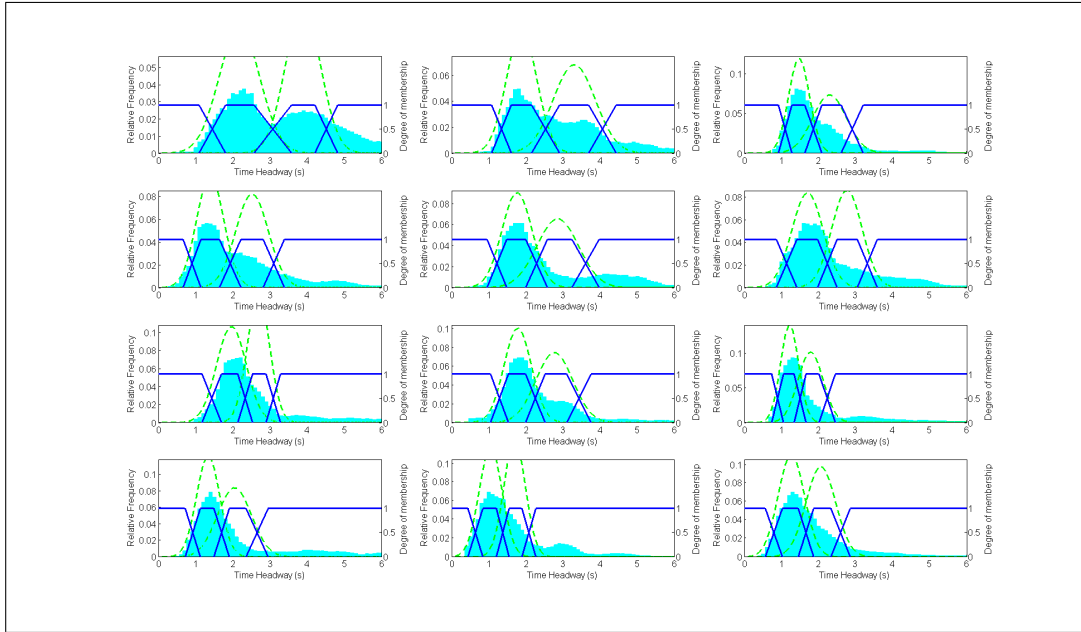

Figure B.7: Fuzzy variables for *Time Headway*, drivers 1-12

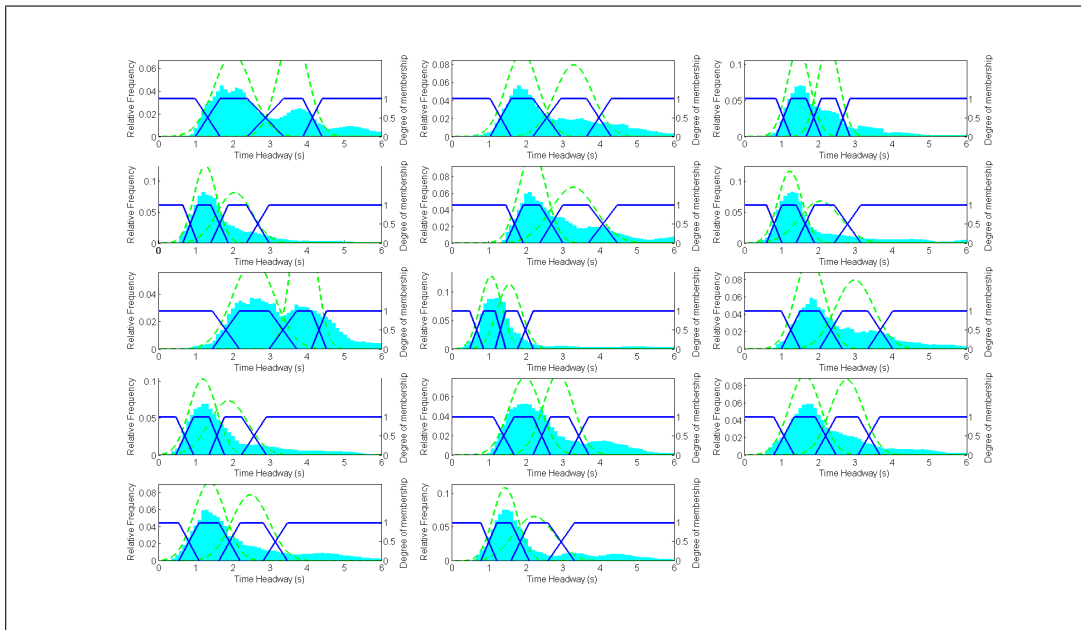

Figure B.8: Fuzzy variables for *Time Headway*, drivers 13-26

B. FUZZY VARIABLES OF THE FIELD STUDY

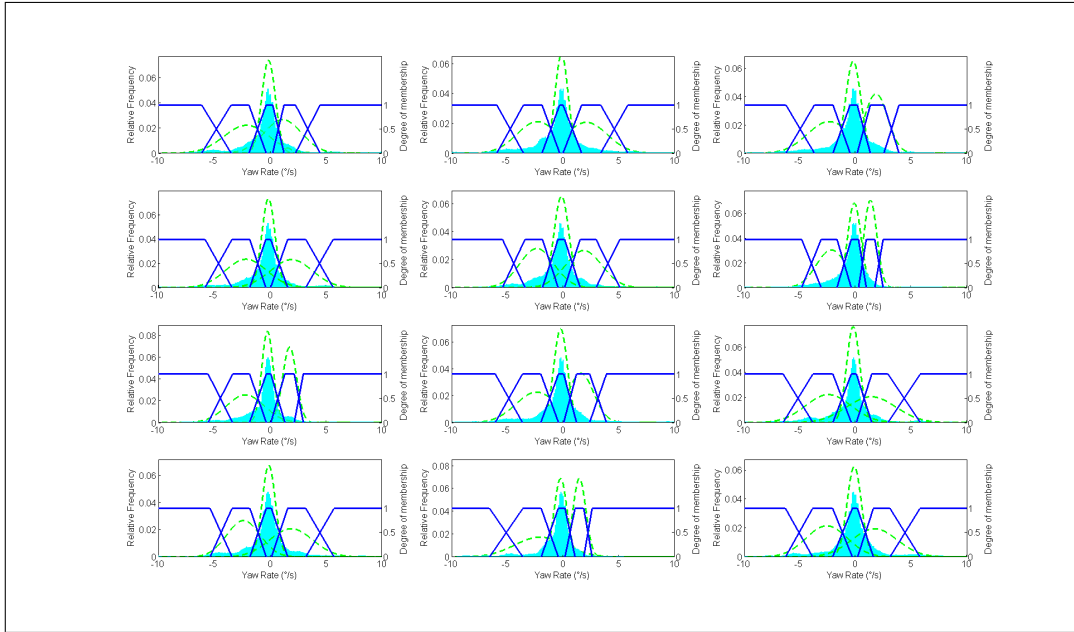

Figure B.9: Fuzzy variables for *Yaw Rate*, drivers 1-12

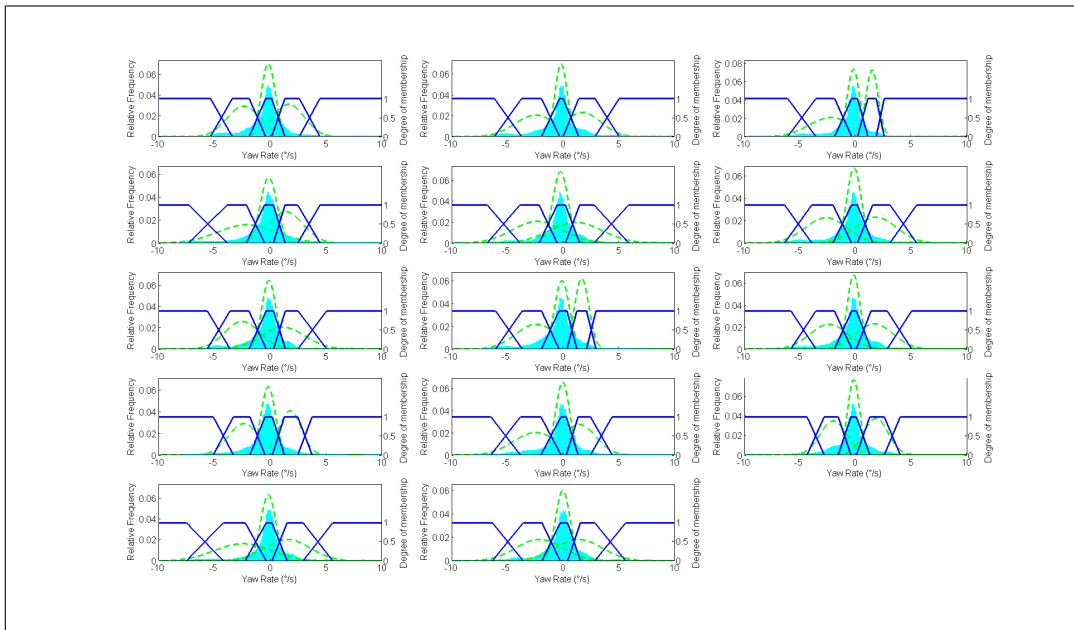

Figure B.10: Fuzzy variables for *Yaw Rate*, drivers 13-26

Appendix C

Situation criticality variables of the field study

This section depicts the fuzzy variables describing the situation criticality required by the autonomous braking algorithm for the 26 drivers who participated in the field study.

C. SITUATION CRITICALITY VARIABLES OF THE FIELD STUDY

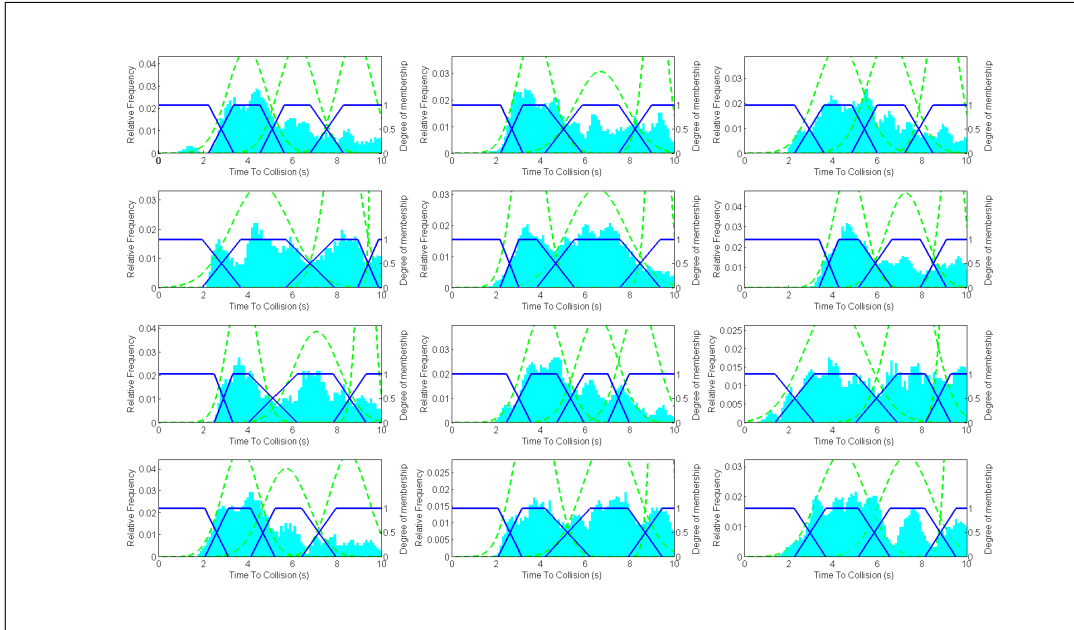

Figure C.1: Driver-dependent situation criticality, drivers 1-12

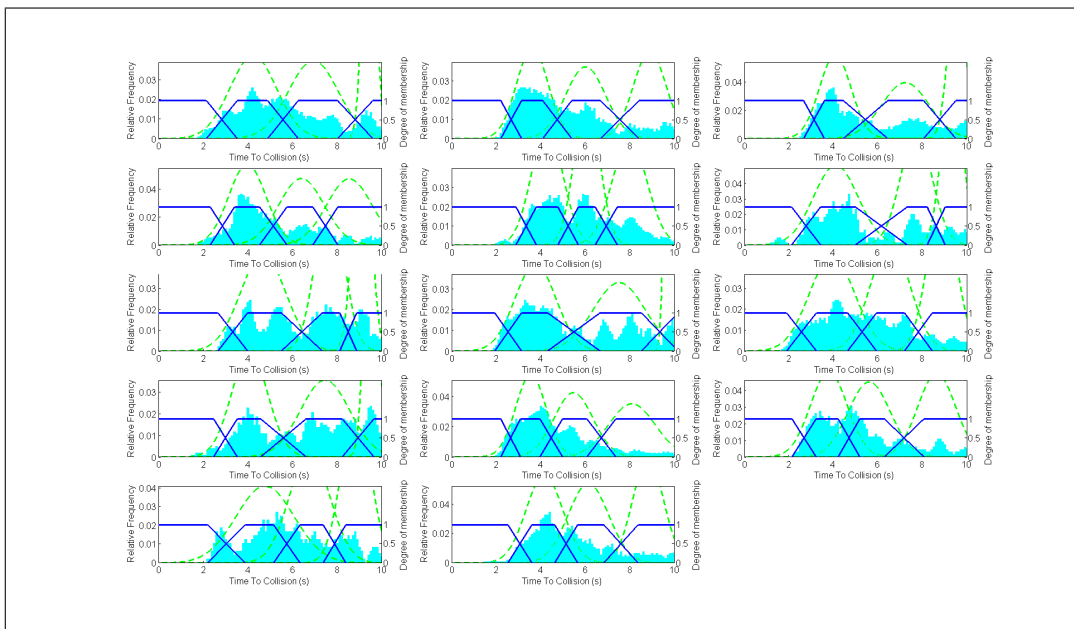

Figure C.2: Driver-dependent situation criticality, drivers 13-26

Appendix D

Situation criticality variables of the simulator study

This section depicts the fuzzy variables describing the situation criticality required by the autonomous braking algorithm for the 20 drivers who participated in the simulator study.

D. SITUATION CRITICALITY VARIABLES OF THE SIMULATOR STUDY

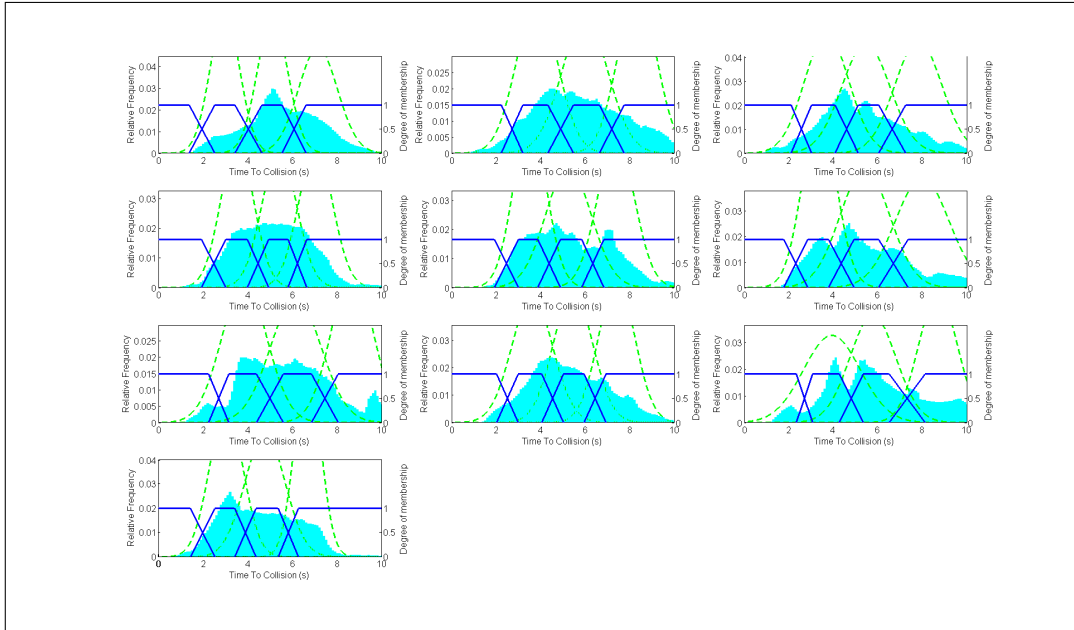

Figure D.1: Driver-dependent situation criticality (simulator study), drivers 1-10

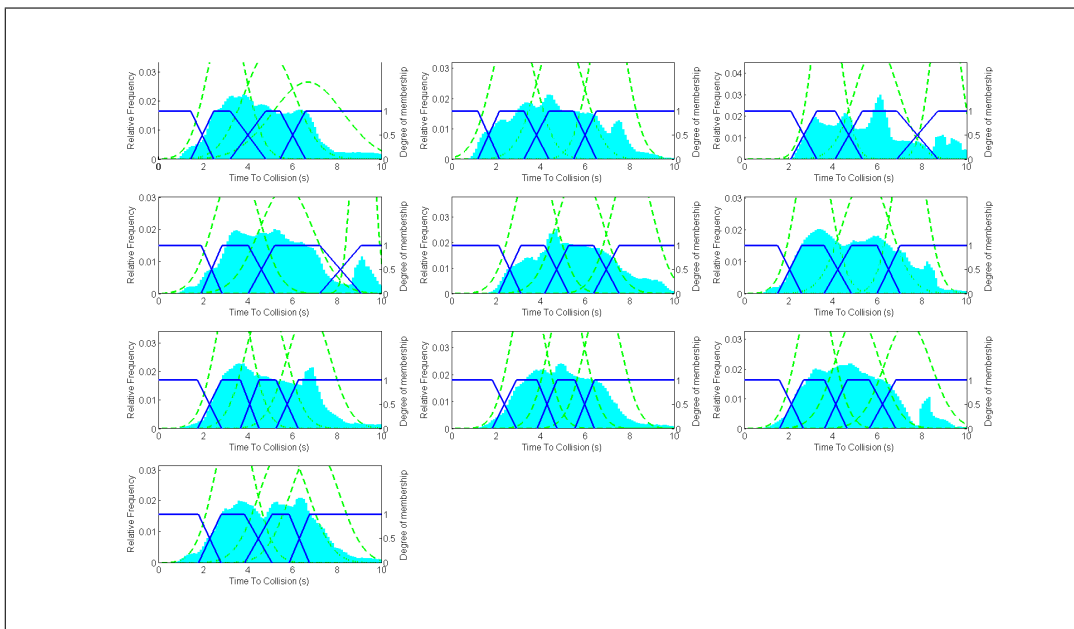

Figure D.2: Driver-dependent situation criticality (simulator study), drivers 11-20

This page is intentionally left blank. The printed version contains a CV in this location.